













Ingenious Tools

A collage of various HAZET tools. In the upper left, a large adjustable wrench is shown. In the center, a screwdriver with a textured handle and the HAZET logo is prominent. To the right, a blue metal toolbox with drawers is visible. In the lower center, a pair of pliers is shown. In the bottom right, a black power tool, possibly a drill or impact driver, is partially visible. The background is a blue and yellow gradient with a grid pattern.

2005

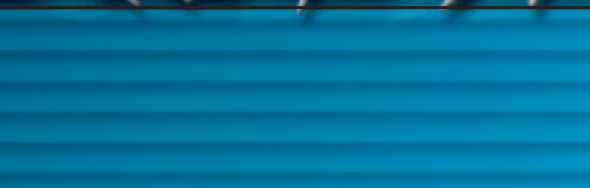
HAZET No.	Legend © = News		Page 2 3-6
111– 190	Tool Cabinets Work Benches, Tool Chests Toll Trolleys „Assistant“ Accessories, Assortments Tool Boxes		7-28
279– 799	Wrenches, Hex-Nut Drivers, Open End Wrenches, Box End Wrenches, Flexible Head Wrenches, Tire Irons, Four-Way Rim Wrenches, Chisels, Punches, etc. Grip Pliers, Universal Pliers, Rim Wrenches, Pullers, Valve Tools, Piston Ring Pliers, Brake Spring Pliers, Hose Clamp Pliers, etc.		29-45
801– 849	Screwdrivers, Scrapers, Screw Extractors, Stud Extractors, Nut Splitters, Tap and Die Set		46-52
850– 1557	Range of Sockets, Socket Sets, Impact Sockets, Tool Sets, TORX® Tool Sets		52-80
1800– 2195	Pliers, Body and Fender Tools, Sheet Metal Crimping Tools, Sheet Metal Snips, Impact Pullers, Hack Saws, Hex Head Wrenches, Additional Tools, Oil Filter Tools, Tube Cutters, Tube Flaring Tools		80-101
2200– 2351	Screwdriver Bits, Adapters, Impact Screwdrivers and Accessories		102-106
2450– 4970	Specialty Tools for HARLEY-DAVIDSON, VW-AUDI, MERCEDES-BENZ, BMW, OPEL, PORSCHE, FORD, CHRYSLER, FIAT, PEUGEOT, RENAULT, CITROËN, TOYOTA, MAZDA, NISSAN, HONDA, MITSUBISHI, Carburettor, Injection System, Oil Service, Battery Service, Electronic, Shock Absorbers, Cooling Systems, Brakes		107-147
5000 CT 5000 CLT 6000 CT 7900 E	Torque Tools		148-158
9000	Pneumatic Tools		159-160
	© Components and Spare Parts Classification to Vehicles Table Equivalent Alphabetical and Numerical Index General Safety Recommendations Suggestion for Improvement Notes		161-170 171-190 191-192 193-195 198 199 200

EAN-No.
4000896+

EAN = European Article Number
The EAN-Code facilitates the identification of an article in all sales documents.

EAN -13 digits:

1 up to 17 = basic No.
8 up to 12 = article No.
8 bis 13 = check digit

EAN-code in our Price List:

The basic No. always is the same and indicated in the corresponding headline, the article No. and the check digit can be found in the specific article description.

When handling, please use the 13 digits of the code.

Furthermore, the code is always valid for one unit (assortment/piece/pair/set.)

For your orders, please still use our article numbers

e. g.: 10 pcs. 450 N -13 x 15

A	American sizes
<i>b</i>	width
<i>l</i>	length
<i>l_i</i>	blade length
<i>l_t</i>	total length
M	metric threads
S	span of the jaw
<i>sb</i>	jaw capacity
<i>sf</i>	span depth
<i>t</i>	depth
V	chrome-plated
VKH	chrome-plated, bright heads
EP	European Patent Application
	Components and Spare Parts (Pages 161-170)



for slotted screws



for Phillips-Recess screws (PH)



for Pozidriv screws (PZ)



for inside hexagon screws



for outside hexagon screws



for inside **TORX**® screws



for tamper resistant **TORX**® screws (inside **TORX**® screws with pin)



for outside **TORX**® screws



mm

TORX® size in mm



TORX® is a registered trademark of CAMCAR TEXTRON INC. Rockford, Illinois, USA
HAZET is licensee for the manufacture of **TORX**® tools



for screws with internal serration (XZN)



for screws with internal serration with pin



for spline socket screws (RIBE CV)



for polydrive screws



for inside 5-star screws with pin



for Tri-Wing® screws



for Torq-Set® screws



TRACTION profile 6-point



TRACTIONS profile 12-point



Protected to standard E IEC 78, (C0) 11, according to VDE 0680 and IEC 900

square drive:



6.3 1/4"

Nominal Size 6.3



10 3/8"

Nominal Size 10



12.5 1/2"

Nominal Size 12.5



20 3/4"

Nominal Size 20



25 1"

Nominal Size 25



Female square



Male square



Female hexagon



Male hexagon



Female connection (Torque Wrenches)



Drive of Insert Tools (Torque Wrenches)



For flat material on Pliers



For round material on Pliers



Centre Cutter



Flush Cutter



Round Nose Pliers



Flat Nose Pliers



Snipe Nose Pliers



New in Illustrated List 2005

These graphic indications facilitate the work within the field of automobile related professions and technologies.



Body



Drivetrain



Chassis

Axes/Shock Absorbers
Wheels/Steering Tie Rods



Oil Service



Exhaust System



Gearbox/Shaft



Motor Electricity



Spark Plug
Glow Plug



Cylinder Head
Valves



Test Equipment



Engine Block
Cooling Water Pump
Hose Connections



Distributor
Generator



Engine Components
Fuel Supply
Carburettor/Fuel Injection



Clutch



Starter



Battery



Piston



Steering



Brakes



General
Workshop Equipment



Passenger Cars



Commercial Vehicles



Agricultural Machinery



Motorcycles













Industry

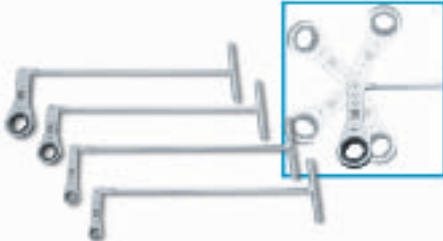

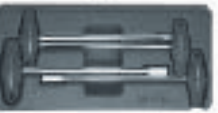

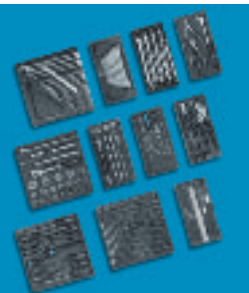



















Aircraft and Aerospace







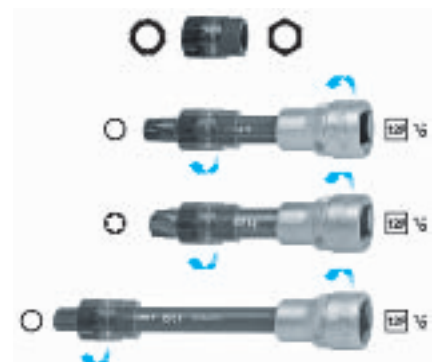









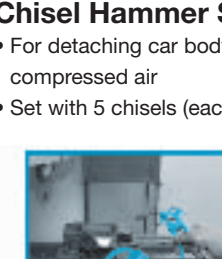

H.I.T.S.
HAZET INFORMATION
TECHNICAL SERVICE
Additional information available
on CD-ROM or videotapes

	Page	HAZET No.		Page	HAZET No.
 <p>Tool Hooks</p>	8	112-230 up to 850	 <p>Ratcheting Combination Wrenches</p> <ul style="list-style-type: none"> Box-end wrench with ratchet function, reversible, actuation angle 5° 	33	606-8 up to 19
 <p>Tool Bin</p>	12	173-6	 <p>Ratcheting Box-End Wrenches</p> <ul style="list-style-type: none"> With T-handle Extremely long – especially suitable for areas with restricted access Pivoting, > 90° 	35	622-10 up to 14
 <p>Tool Trolley Innovative and sturdy pillar construction, integrated ram protection</p>	14	180-6 up to 9	 <p>Pliers for Wheel Nut Caps</p> <ul style="list-style-type: none"> For the damage-free removing of wheel nut caps on aluminium rims 	37	666-10
 <p>Tool Assortment</p>	18	161-57 P/4	 <p>Hose Clamp Pliers</p> <ul style="list-style-type: none"> For the operation of multi-use Clic-type hose clamps Movable jaws 	44	798-3
 <p>Tool Assortment Especially for tool trolleys, 193 parts</p>	22	0-9/193	 <p>Hose Clamp Pliers</p> <ul style="list-style-type: none"> For the operation of spring band hose clamps whose three ends are directly located on the tube, e.g. on fuel lines and tank ventilation lines 	45	798-14
 <p>Mobile Tool Case 84 parts</p>	27	150/84	 <p>Lever for Removing Door Panels</p> <ul style="list-style-type: none"> For removing the fixing plugs on door panels Lever provides an optimal power transmission when removing the panel 	45	799-6

	Page	HAZET No.		Page	HAZET No.
 <p>Screwdrivers with Impact Cap</p> <ul style="list-style-type: none"> Multi-component handle Impact cap made of tempered steel 	47	801 U/5		85	1849-8
 <p>Socket Set</p> <ul style="list-style-type: none"> 33 parts 	56	854 T	6.3 1/4"	92	1979-1
 <p>Screwdriver Sockets</p> <p>For installing and removing the wheel bearings/hub unit of the rear axle on AUDI A 3 since 2004, VW Touran since 2004</p>	68	990-18	12.5 1/2"	95	2128-1
 <p>Screwdriver Sockets</p> <ul style="list-style-type: none"> Long style For screws with internal serration (XZN) 	68	990 Lg-9	12.5 1/2"	98	2169-10
 <p>TORX® Screwdriver Sockets</p> <ul style="list-style-type: none"> Long style For inside TORX® screws 	68	992 Lg-T 50	12.5 1/2"	98	2169-5
 <p>TORX® Screwdriver Sockets</p> <ul style="list-style-type: none"> Extra long style For inside TORX® screws 	68 68	992 S Lg-T 40 T 50	12.5 1/2"	98 99	2169-5 2169-7
 <p>Remover</p> <ul style="list-style-type: none"> For removing and installing ignition coils on various VW-vehicles 	85	1849-7		99	2169-8
 <p>Remover</p> <ul style="list-style-type: none"> For removing and installing ignition coils on various VW-vehicles 					
 <p>Rechargeable Utility Light</p> <ul style="list-style-type: none"> Optimal illumination of the work area 7 ultra bright, white LED (530 LUX) 					
 <p>Twist Drill Bits in Case</p> <ul style="list-style-type: none"> HSS-G Ø 1 - 13 mm, increasing by 0.5 mm 118° standard point 					
 <p>Oil Filter wrench</p> <ul style="list-style-type: none"> Flat Style: continuous 14-point profile up to the edge 			10 3/8"		
 <p>Oil Filter Wrenches</p> <p>□ drive 12,5 = 1/2", resp. outside hexagon 24 mm</p> <p>18-point s 135 mm on MAN-commercial vehicles of the series F 2000 and TGA</p> <p>14-point s 64 mm on TOYOTA Yaris, Corolla, MR2 until 1999, Starlet, Celica, Avensis, NISSAN Micra, Almera, MAZDA 323, 626, MX-5, Xedos</p> <p>15-point s 74 mm on OPEL (oil filters with T-No. 650 401), Kadett E, Corsa A, B, C, Omega A, B, Astra F, G, Vectra A, B, Calibra, Frontera, SAAB 900 2.5 I, 9000 3.0 I, LADA Shiguli 2110 2.0 I</p>			12.5 1/2"		

	Page	HAZET No.		Page	HAZET No.
 <p>Oil Filter Wrenches 12⁵ 1/2</p> <p>□ drive 12,5 = 1/2", resp. outside hexagon 24 mm</p> <p>Purflux filters s 66 mm groove profile Purflux filters s 86 mm groove profile Purflux filters s 96 mm groove profile</p>	99	2169-66	 <p>Combinational Socket Set</p> <ul style="list-style-type: none"> • For working at the generator, either installed or dismantled • For installing and removing the V-ribbed belt pulley at the generator • Checking of the screwed connection 	132	4642/2
 <p>Retainer with Exchangeable Pins</p> <ul style="list-style-type: none"> • For installing and removing the toothed belt pulleys on the camshaft, crankshaft and fuel injection pump on various VW-vehicles 	110	2540-1	 <p>Special Tool for Battery Plugs</p> <ul style="list-style-type: none"> • For screwing the battery plugs in and out 	133	4650-3
 <p>Camshaft Locking Tool</p> <ul style="list-style-type: none"> • For locking the camshaft pulleys when changing the toothed belt • Engine repair on 4-cylinder, 4-valve injection engines on various VW-vehicles 	112	2588-4	 <p>Socket Extension</p> <p>For installing and removing the electronic control unit through the windscreen (driver's side) on various AUDI-vehicles</p>	140	4775-8
 <p>Open-End Insert Tool</p> <ul style="list-style-type: none"> • For the operation of the oil pressure switch on MERCEDES-BENZ commercial vehicles • Extra flat style 	119	2870-24	 <p>Engine Leakage Tester</p> <p>Adapter for multi-valve engines</p>	140	4795-15
 <p>Combinational Socket Set</p> <ul style="list-style-type: none"> • For working at the generator, either installed or dismantled • For installing and removing the V-ribbed belt pulley at the generator • Checking of the screwd connection • Screwdriver Sockets with TORX® and XZN profile for various inside screw profiles 	132	4641/4	 <p>Adapter for Tester for Cooling Systems</p>	141	4800-17
			 <p>Endoscope</p> <ul style="list-style-type: none"> • For damage diagnosis • 4 times brighter than conventional endoscopes • Very small bending radius (30 mm) for areas with restricted access • Water-proof endoscope probe. Allows even short-time use in oil or gasoline <p>90°-mirror (side-view adapter)</p>	141	4811-1/2
				141	4811-2

	Page	HAZET No.		Page	HAZET No.
 <p>Track Rod Wrenches</p> <ul style="list-style-type: none"> • For the operation of the track rod screwing • Double, spring bearing jaw opening prevents slipping off, especially when screws are seized or very tight • Forged design 	146	4950-13 up to 22	 <p>Air Ratchets</p> <ul style="list-style-type: none"> 35 Nm 70 Nm 70 Nm 	160	9020-2
 <p>Torque Wrenches</p> <ul style="list-style-type: none"> • Click-Lens-Type. Large digits for an exact and easy reading of the torque value <p>20-120 Nm</p> <p>40-200 Nm</p> <p>60-320 Nm</p> <p>50-250 lbf. ft.</p>	149	5121-2 CLT	 <p>Air Drill</p> <ul style="list-style-type: none"> • Quick change chuck, Capacity 1-10 mm • Suitable for continuous operation 	160	9021-2
 <p>Impact Wrenches</p> <ul style="list-style-type: none"> • Ultra-light magnesium housing • Powerful impact mechanisms • Reduced vibrations <p>250 Nm</p> <p>740 Nm</p> <p>1490 Nm</p> <p>2160 Nm</p>	149	5122-2 CLT	 <p>Air Drill</p> <ul style="list-style-type: none"> • Quick change chuck, Capacity 1-10 mm • Suitable for continuous operation 	160	9022-2
 <p>Impact Wrench</p> <ul style="list-style-type: none"> • Maximum performance at minimum weight • Shock-resistant plastic housing • Powerful twin hammer mechanism 	159	5123-2 CLT	 <p>Chisel Hammer Set</p> <ul style="list-style-type: none"> • For detaching car body sheets with compressed air • Set with 5 chisels (each 175 mm long) 	160	9035/6
 <p>Impact Wrench</p> <ul style="list-style-type: none"> • Maximum performance at minimum weight • Shock-resistant plastic housing • Powerful twin hammer mechanism 	159	5128-2 CLT	 <p>Air Blow Guns</p> <ul style="list-style-type: none"> • For the fast removing and cleaning of chips and other kinds of impurities • With non-slip handle • Body material: nylon, nozzle material: steel • Nozzle length continuously adjustable 	160	9030-1
 <p>Impact Wrench</p> <ul style="list-style-type: none"> • Maximum performance at minimum weight • Shock-resistant plastic housing • Powerful twin hammer mechanism 	159	9011 MG	 <p>Air Blow Guns</p> <ul style="list-style-type: none"> • For the fast removing and cleaning of chips and other kinds of impurities • With non-slip handle • Body material: nylon, nozzle material: steel • Nozzle length continuously adjustable 	160	9040-1
 <p>Impact Wrench</p> <ul style="list-style-type: none"> • Maximum performance at minimum weight • Shock-resistant plastic housing • Powerful twin hammer mechanism 	159	9012 MG	 <p>Air Blow Guns</p> <ul style="list-style-type: none"> • For the fast removing and cleaning of chips and other kinds of impurities • With non-slip handle • Body material: nylon, nozzle material: steel • Nozzle length continuously adjustable 	160	9040-2
 <p>Impact Wrench</p> <ul style="list-style-type: none"> • Maximum performance at minimum weight • Shock-resistant plastic housing • Powerful twin hammer mechanism 	159	9013 MG	 <p>Air Blow Guns</p> <ul style="list-style-type: none"> • For the fast removing and cleaning of chips and other kinds of impurities • With non-slip handle • Body material: nylon, nozzle material: steel • Nozzle length continuously adjustable 	160	9040-3
 <p>Impact Wrench</p> <ul style="list-style-type: none"> • Maximum performance at minimum weight • Shock-resistant plastic housing • Powerful twin hammer mechanism 	159	9014 MG	 <p>Pocket Blow Pen</p> <ul style="list-style-type: none"> • Practical and compact design with clip for the fixation in pockets • Easy handling, clicks directly on air coupling 	160	9040-3
 <p>Impact Wrench</p> <ul style="list-style-type: none"> • Maximum performance at minimum weight • Shock-resistant plastic housing • Powerful twin hammer mechanism 	159	9012 KS	 <p>Pocket Blow Pen</p> <ul style="list-style-type: none"> • Practical and compact design with clip for the fixation in pockets • Easy handling, clicks directly on air coupling 	160	9040-3

Tool Cabinet



1000 x 840 x 250



empty, with blind, lockable

HAZET
No.

EAN-No.
4000896+

111 L

003266

Tool Cabinet with Assortment

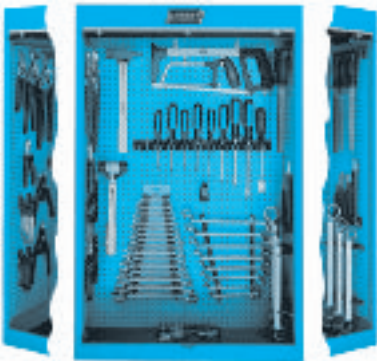

1000 x 840 x 250



with tool assortment 86 parts

contents:

- 603-6 7 8 9 10 11 12 13 14
- 15 16 17 18 19 21 22 24
- 630-6x 7 8x 9 10x11 12x13 14x15
- 16x17 18x19 20x22 21x23 24x27
- 30x32
- 730-3 6 746-1 748b-3 4 5 6
- 760N-1 2 3
- 801-40 55 80 100
- 801-PH 1 PH 2 PZ 1 PZ 2 824
- 850-4 4,5 5 5,5 6 7 8 9 10 11
- 863P 867-2 868 869
- 1802-11 1845A-19 1845C-19
- 1952-35 1980N 1981
- 2100-02 025 03 04 05 06 08
- 2115-T 8 T10 T15 T20
- T25 T30 T40
- 2120-8 2122-8 2123-8 2140-5 2154

HAZET
No.

EAN-No.
4000896+

111/86

003136

Tool Hangers



for tool assortment 86 parts 0-111/86

HAZET
No.

EAN-No.
4000896+

111/86 HL

003143

Tool Assortment



86 parts,
contents see tool assortment 111/86,
without tool cabinet

HAZET
No.

EAN-No.
4000896+

0-111/86

000104

Tool Cabinet with Assortment

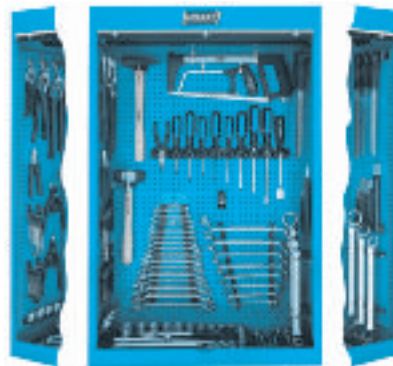

1000 x 840 x 250



with tool assortment 116 parts

contents:

- 603-6 7 8 9 10 11 12 13 14
- 15 16 17 18 19 21 22 24
- 630-6x 7 8x 9 10x11 12x13 14x15
- 6x17 18x19 20x22 21x23 24x27 30x32
- 730-3 6 746-1 748b-3 4 5 6
- 760N-1 2 3
- 801-40 55 80 10
- 801-PH 1 PH 2 PZ 1 PZ 2 824
- 850-4 4,5 5 5,5 6 7 8 9 10 11
- 863P 867-2 868 869
- 900-10 11 12 13 14 15 16 17 18 19
- 20 21 22 23 24 26 27 28 30 32
- 915 916SP 917-5 918-10 920
- 985-5 6 8 10
- 1802-11 1841 a-22 1845A-19 1845C-19
- 1952-35 1980N 1981
- 2100-02 025 03 04 05 06 08
- 2115-T8 T10 T15 T20 T25 T30 T40
- 2120-8 2122-8 2123-8 2140-5 2154

HAZET
No.

EAN-No.
4000896+

111/116

003105

Tool Assortment

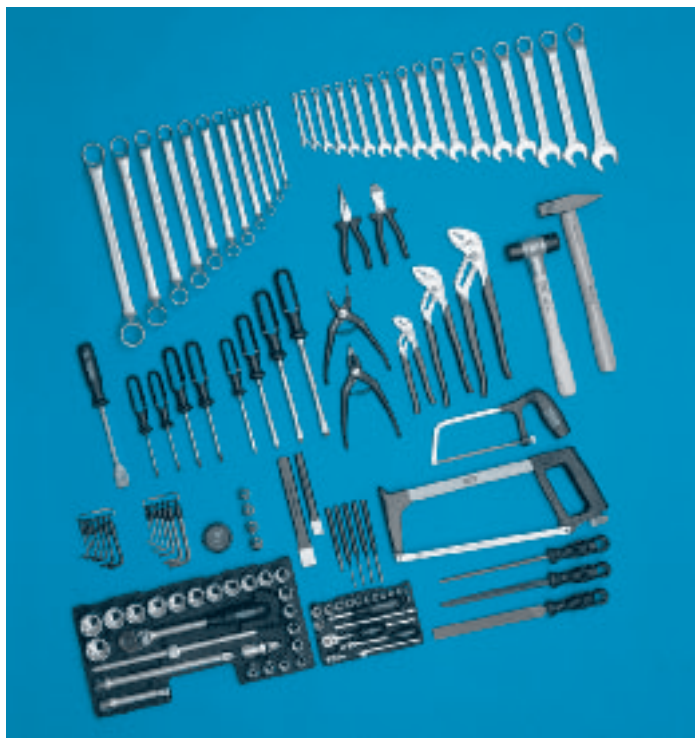

116 parts,
contents see 111/116,
without tool cabinet

HAZET No.	EAN-No. 4000896+
0-111/116	000098

Tool Hangers

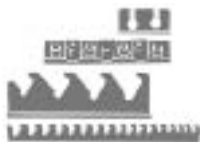

for tool assortment with 116 parts 0-111/116 HL

HAZET No.	EAN-No. 4000896+
111/116 HL	003112



111-01 R



111-04



111-13



111-21



111-23

HAZET No.	EAN-No. 4000896+
111-01 R	002788
111-01 L	002764
111-01 R-K	002795
111-01 L-K	002771
111-02 R	002818
111-02 L	002801
111-03 R	002849
111-03 L	002832
111-04	002856
111-05	002863
111-06	002870
111-07	002887

Tool Hangers

HAZET No.	EAN-No. 4000896+
111-08	002894
111-09	002900
111-11	002924
111-12	002931
111-13	002948
111-14	002955
111-15	002962
111-16	002979
111-17	002986
111-20	003013
111-21	003020
111-22	003037
111-25	003068
111-28	003099

Tool Hooks

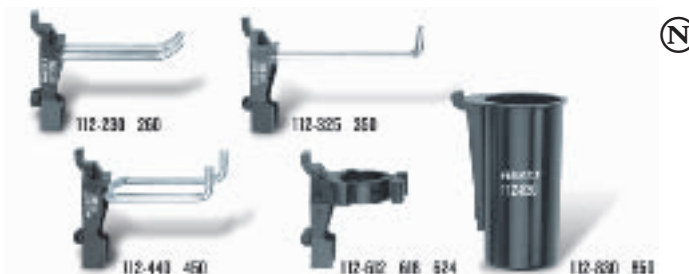

Suitable for perforated panels with square perforations
(e.g. the rear panel at the Tool Trolley 176-1, 180-6 to -9)

HAZET No.	EAN-No. 4000896+
Double hook, 30 mm long	
112-230	103898
Double hook, 60 mm long	
112-260	103881
Hook, 25 mm long	
112-325	103874
Hook, 50 mm long	
112-350	103867
Double hook, wide, 40 mm long	
112-440	103850
Double hook, wide, 50 mm long	
112-450	103843
Clip, ϕ 12 mm	
112-612	103836
Clip, ϕ 18 mm	
112-618	103720
Clip, ϕ 24 mm	
112-624	103713
Plastic cup, ϕ 30 mm, 80 mm high	
112-830	103706
Plastic cup, ϕ 50 mm, 114 mm high	
112-850	103690
Tool Hook Set	
11 parts: 1 part each	
112-230 260 325 350 440 450 612 618 624 830 850	
112/11	104239

Work Bench



with front steel lining

HAZET No.	EAN-No. 4000896+
130-1	003358

Rear Panel



111 mm high, made of a multilayer beech plate

HAZET
No.

EAN-No.
4000896+

130-R

003389

Adjustable Legs



4 parts, vertically adjustable up to 40 mm

HAZET
No.

EAN-No.
4000896+

130-F/4

003365

HAZET Tool Trolleys – reliable quality based upon decades of experience



- ✔ *High-quality materials as well as best fabrication techniques ensure a long service life*
- ✔ *Big running castors with high loading capacity*
- ✔ *Suitable for HAZET plastic drawer inserts*
- ✔ *Well thought-out solutions for the mobile working place*
- ✔ *100.000 times proven quality for trade and industry*
- ✔ *Extremely high loading capacity*



Tool Trolleys

Assistant (E)



1054 x 725 x 398

- Approx. 50% higher capacity than the preceding model
- Plastic table board with integrated beech wood board, replaceable
- Intermediary containers suitable for HAZET plastic drawer inserts
- With additional sliding tray, to be integrated into the intermediary containers, e.g. for caliper gauges and small parts
- Spacious bottom container made of sheet steel
- Big castors to level out uneven ground surfaces
- Collapsible, lockable
- Provided with wraparound protecting rubber strips
- Protected by design patent

HAZET
No.

EAN-No.
4000896+

162 C

072279

Container for small parts
for 162 C and 166 C

162 C-5

078189

Separation sheet for intermediary tray
for 162 C and 166 C

162 C-6

079810

Tool Trolleys

Assistant (E)



1054 x 725 x 398

like HAZET 162 C
but with collapsible swinging down pillars to reduce the height
to a space saving minimum (642 mm)

HAZET
No.

EAN-No.
4000896+

166 C

072286

Container for small parts
for 162 C and 166 C

162 C-5

078189

Separation sheet for intermediary tray
for 162 C and 166 C

162 C-6

079810

Tool Trolleys

Assistent (E)



594 x 635 x 400

- With 4 drawers
- Sliding out on both sides
- Individual locking prevents the drawers from slipping through
- Central locking
- Loading capacity stationary 500 kg
- Loading capacity mobile 300 kg
- Loading capacity of each drawer 20 kg
- 894 x 635 x 480 mm
- Surface powder coated, blue, worktop with rubber mat

HAZET No.	EAN-No. 4000896+
168	048649

Tool Trolleys

Assistent (E)



995 x 675 x 540

- 6 drawers with high loading capacity
- Interchangeable drawers – individual equipment of the trolley
- 100 % sliding-out
- With plastic worktop
- Central locking
- Loading capacity stationary 500 kg
- Loading capacity mobile 300 kg
- Loading capacity of each drawer 25 kg
- 995 x 675 x 540 mm
- Surface powder coated, blue

HAZET No.	EAN-No. 4000896+
170-6	059997

Assistent (E)



169 N
670 x 750 x 550

169 N-7
970 x 750 x 550

- 6 drawers with high loading capacity
- 100 % sliding-out
- Central locking
- Stable wheel suspension
- Plastic worktop with storage wells for screwdrivers, pliers, etc.
- Loading capacity stationary 500 kg
- Loading capacity mobile 300 kg
- Loading capacity of each drawer 25 kg
- 970 x 770 x 550 mm
- Surface powder coated, blue, further colours available on demand

HAZET No.	EAN-No. 4000896+
169 N	059218

description see 169 N but with **7 drawers**

169 N-7	087235
---------	--------

Tool Chest

Assistent



455 x 670 x 400

- To be installed on Tool Trolley 170-6 or under Work Bench 130-1.
 - Central locking, lockable with common padlock (e.g. HAZET 168-08 a).
 - With 5 interchangeable drawers
 - 2 drawers each 40 mm, 3 drawers each 82 mm high
- Surface powder coated, blue

HAZET No.	EAN-No. 4000896+
170 K-5	060023

Fixing Rails for Tool Chest

for fixing the Tool Chest 170 K-5 under the Work Bench HAZET 130-1

170 K-1	060207
---------	--------

Adjusting Pins

for fixing the Tool Chest 170 K-5 on Tool Trolley 170-6

170 K-2/4	060139
-----------	--------

Tool Trolley

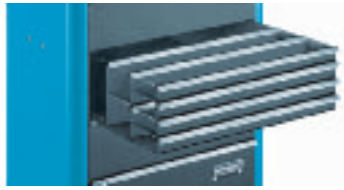

Assistant

HAZET No.

EAN-No. 4000896+

like HAZET 170-6, empty to be filled up individually surface powder coated, blue

170 L 060160

Tool Chest Housing

like HAZET 170 K-5, but empty, drawers to be filled up individually surface powder coated, blue

170 KL 064359

Drawers

for 170 L, resp. for exchanging the drawers of HAZET 170-6 and 170 K-5, 40 mm high,

with ball bearing rails surface powder coated

170-40 060177

82 mm high, **with ball bearing rails**

170-82 060184

167 mm high, **with ball bearing rails**

170-167 060191

Pair of ball bearing rails

for fixing the drawers in HAZET 170-6, 170 K-5, 170 L

170-07 060245

Attachment Parts



Assistant

HAZET No.

EAN-No. 4000896+

Tool Cabinet

for 170-6 also suitable for wall fixation fixing kit included surface powder coated

170-1 060085

Work Top folding down

for HAZET 170-6 fixing kit included surface powder coated

170-2 060047

Paper Bin

for HAZET 170-6, 173, 176-1 and 180 fixing kit included

170-3 060054

Holder for Paper Reel

for HAZET 170-6, 173, 176-1 and 180 fixing kit included

170-4 060061

Attachment Parts



Assistant

HAZET No.

EAN-No. 4000896+

Wooden Worktop

for 170-6, 170 K-5 and 170 L as replacement of the plastic worktop, dimensions 646 x 377 x 30

170-5 060030

Tool Trolleys



Assistant (E)

- With shutter and wire mesh
- Lockable
- Enables easy look at the contents and good lighting conditions
- With two intermediary trays as well as 2 drawers for tool storage
- Loading capacity stationary 500 kg
- Loading capacity mobile 300 kg
- Loading capacity of each drawer 20 kg
- 950 x 700 x 485 mm

HAZET No.

EAN-No. 4000896+

171 005383



Assistant (E)

- Extremely sturdy
- With shutter and wire mesh
- Lockable
- With two intermediary trays as well as 1 drawer for tool storage
- Loading capacity stationary 900 kg
- Loading capacity mobile 400 kg
- Loading capacity of drawer for small parts 5 kg
- Especially suitable for commercial vehicles
- 1020 x 850 x 450 mm

HAZET No.

EAN-No. 4000896+

172 HD 005819

Tool Trolleys



Assistant (E)

- The Tool Trolley that accommodates the double loading capacity in comparison to standard tool trolleys meets increased demands of the modern mechanic. The constantly rising variety of passenger cars calls for always new and bigger tool assortments.
- Central locking system allows mutual drawer locking (according to EN 1757-3): For safety reasons only one of the eight big drawers can be opened at a time.
- Side-locker for valuable objects or valuable tools, e.g. Torque Wrenches.
- One key fits in every lock.
- Laterally extendable leaf for testing devices, laptops, etc.
- Edges are protected by flexible profile strip against damages.
- Big and sturdy castors, total loading capacity 750 kg
- High-quality processing and exclusive design (DBGM – German registered utility model)
- Drawers:
 - High loading capacity of 35 kg per drawer
 - 7 small (70 mm high) and 1 big (140 mm high) drawer
 - Each drawer is 100% sliding-out
 - Ball bearing telescopic rails
 - Equipped with 21 separation sheets (60 x 397 mm) for individual drawer partition
 - Two small bottom drawers may be replaced by one big drawer
- Choice of worktops:
 - Modern plastic worktop resistant to solvent (173-1) with compartments for screwdrivers and similar tools (suitable for HAZET Plastic Drawer Inserts)
 - Tough multilayer board (173-2) with reception holes for screwdrivers etc.
- Various extension and expansion possibilities:
 - Can holder for e.g. aerosols
 - Holder for paper reel
 - Cable drum

HAZET No.	EAN-No. 4000896+
173-1	089031
173-2	088997
Plastic insert for plastic worktop of 173-1	
173-21	090211
Distance plate (wood) for parallel vice 2175 N for fixation on 173-1 and 176-1 fixing kit included	
173-23	090228
5 Separation sheets (60 x 397 mm) for small drawer of 173	
173-31/5	090150
Separation sheet for high drawer of 173	
173-32	090143
Can holder e.g. for 3 aerosols for HAZET 173, 176-1 and 180, fixing kit included	
173-35	090235
5 small plastic drawer inserts for drawers of 173	
173-36/5	090167
173-38	089789

Tool Trolleys

Assistant (E)

HAZET No.	EAN-No. 4000896+
10 Magnetic labels with paper insert 120 x 25 mm	
173-40/10	090051
Tool Bin Variable subdivision with three separation sheets For Tool Trolleys 169 N since 6/2002, 170-6, 173-1 173-2 176-1	
173-6	099276
Cable Drum for Assistant 170-6, 173, 174, 176-1 and 180 as well as 169 N and 169 N-7 since 2004 with holding device, with 10 m cable, for Assistant without fixing device at the side panel – Export versions available –	
161-3 D	048878
Paper Bin for HAZET 170-6, 173, 176-1 and 180 fixing kit included	
170-3	060054
Holder for Paper Reel for HAZET 170-6, 173, 176-1 and 180 fixing kit included	
170-4	060061

Tool Assortment

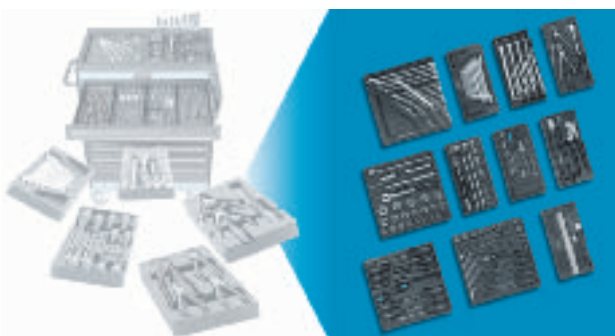

(N)

assortment with 193 parts specially for Tool Trolley 173 see page 22

HAZET No.	EAN-No. 4000896+
0-9/193	110292

Cabinet Trolley for Workshop



Assistant (E)

- For biggest tool assortments
- With swing door, locked in open position at 180°, with perforated sheet steel panel and lockable swivel castor
- 5 drawers, 100% sliding-out, with partitions in different sizes and ball bearing rails

Cabinet Trolley for Workshop

- Metal side pocket for drawings etc.
- Loading capacity stationary 700 kg
- Loading capacity mobile 400 kg
- Loading capacity of each drawer 20 kg
- 1100 x 671 x 495 mm
- Surface powder coated
- EP

Assistant (E)

HAZET No. EAN-No. 4000896+

174 005826

with assortment, 151 parts
tool holders included

174/151 005871

Tool Assortment



for automotive and industrial companies
151 parts, tool holders included

contents:

428-10 12 13
450N-6x 7 8x 9 10x11 12x13 14x15 16x17
18x19 20x22 21x23 24x27 25x28 30x32
600N-6 7 8 9 10 11 12 13 14 15 16 17
18 19 20 21 22 23 24 25 26 27 28 30 32
630-6x 7 8x 9 10x11 12x13 14x15 16x17
18x19 20x22 21x23 24x26 25x28 30x32
730-3 6 746-1
748b-3 4 5 6 757-10 12 760N-1 2
803-20 35 55 100
803-PH1 PH2 PZ1 PZ2 824
850-4 5 6 7 8 9 10 11 12 13 14
8501-3 4 5 6 8
8503-0,6x3,5 0,8x4 1x5,5 1,2x8
8506-PH1 PH2 PH3 PH4
8507-PZ1 PZ2 PZ3
863P 865 866U 867-2 868 869
900-10 11 12 13 14 15 16 17 18 19
20 21 22 23 24 26 27 28 30 32
915 916SP 917-5 918-10 920
1803-22 1841a-22
1952-35 1976 1980N 1981
2100-02 025 03 04 05 06 08
2120-10 2122-10 2123-10 2140-2 5 2154-2 2160
6122-1CT



HAZET No. EAN-No. 4000896+

0-174/151 000173

Assortment of Tool Hangers

for Assistant 174, Tool Cabinet 111 L

HAZET No.	EAN-No. 4000896+
174/41 HL	005888
174/65 HL	005895

Tool Trolleys

Assistant (E)



347 x 764 x 575

- New exclusive design
- New type of cover plate
- Perforated rear panel (rectangular perforation) for the attachment of the tool case HAZET 176-5 for fixing hooks
- Perforations at the side panels offer additional possibility for accessory fixation
- Plastic worktop resistant to solvent with storage wells for screwdrivers and small items
- Worktop with loading capacity of 50 kg
- Drawers:
 - High loading capacity of 20 kg per drawer
 - 5 small and 2 big drawers
 - Appropriate for HAZET Plastic Drawer Inserts
 - All drawers are 100% sliding-out
 - Ball-bearing telescopic rails
 - Equipped with 4 separating sheets for individual drawer partition (further separating sheets 161 T-347 x 60 and/or 161 T-347 x 120 available)
 - Upper big drawer may be replaced by two small drawers
 - Drawers b 523 x f 342 mm:
 - small drawer: h 65 mm / cover plate 80 mm
 - big drawer: h 120 mm / cover plate 160 mm
- Central locking system
- Cylinder lock with hinged key
- 2 ball-bearing swivel castors, 1 castor with brake
2 ball-bearing fixed castors
- Optional accessories:
 - Tool case for rear panel 176-5
 - Can holder for 3 aerosols 173-35
 - Cable drum 161-3 D
 - Paper bin 170-3
 - Holder for paper reel 170-4
 - Window pane holder 161-8
 - Window pane holder 161-9
 - Machinist's Vice 2175 N
 - Wooden liner for a.m. vice 173-23

HAZET No. EAN-No. 4000896+

176-1 100743

Tool case for rear panel

176-5 096671

Tool Trolleys

Assistent (E) (N)



- Innovative, sturdy pillar construction with integrated anti-ram protection
All pillars are suitable for the fixation of accessories
- Plastic worktop is resistant to solvent (loading capacity approx. 125 kg), suitable for the storage of small parts
- Side and rear panels with rectangular perforation for the fixation of accessories and tool hooks
- Drawers:
 - High loading capacity of 25 kg per drawer
 - Suitable for HAZET Plastic Drawer Inserts
 - Two separating sheets per drawer included in delivery
 - All drawers are 100% sliding out
 - Drawers b 523 x f 397 mm
 - Flat drawer h 80 mm panel height
 - Big drawer h 165 mm panel height
- Central locking with mutual drawer locking, only one drawer can be opened at the same time.
Possibility of individual locking for each drawer
- Possibility of drawer labelling
- 2 ball-bearing swivel castors, 1 with brake
- 2 ball-bearing fixed castors
- 1035 x 810 x 570 mm
- German registered utility patent / DBGM
- Optional accessories (*= for fixation with Adapter 180-29):
 - Can Holder for 3 aerosols 173-35*
 - Cable Drum 161-3 D*
 - Paper Bin 170-3*
 - Holder for Paper Reel 170-4*
 - Window Pane Holder 161-8
 - Window Pane Holder 161-9
 - Machinist's Vice 2175 N

HAZET No. EAN-No. 4000896+

Executions:

3 flat and 3 big drawers

180-6 110612

5 flat and 2 big drawers

180-7 110629

7 flat drawers and 1 big drawer

180-8 110636

9 flat drawers

180-9 110643

Tool Trolleys

Assistent (E) (N)

HAZET No. EAN-No. 4000896+

Accessories:

Door, lockable for right or left side panel

180-21 110797

Wooden multilayer board to be inserted into plastic worktop

180-22 110803

Metal board, grooved aluminium to be inserted into plastic worktop

180-23 110810

Document Holder for working documents

180-24 110827

Support for small parts, attachable, magazine for screws and other small parts

180-25 110834

Vertical Tool Panel attachable, for the fixation of additional tools

180-26 110841

Work Tray, attachable, swivelling, as additional writing board, place for documents, laptop etc.

180-27 110858

Shelf Bottom, to be hooked into rear panel

180-28 110865

Fixation Adapter, for the fixation of 161-3, 170-3 -4, 173-35 at the perforated side panel

180-29 110872

Drawer Partition System

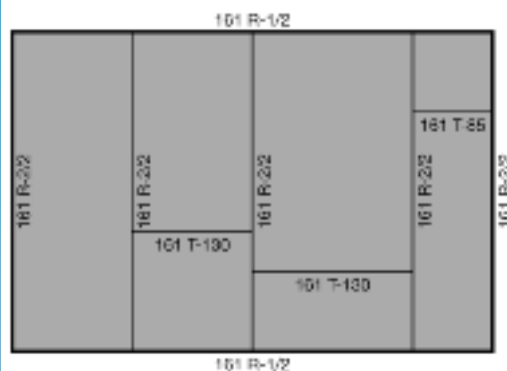

Raster strips and separation sheets for arbitrary drawer partition of the Assistent 169 N, 170-6, 174 and 176-1

HAZET No. EAN-No. 4000896+

Separation sheets for the new drawers (since 2000) with laterally integrated fixing devices,

length 347 mm, height 60 mm

161 T-347 x 60 080328

length 347 mm, height 120 mm

161 T-347 x 120 080311

Note: please use the following raster strips for drawers up to 2000 (without integrated fixing devices):

Drawer partition for Tool Trolleys up to 2000 basic assortment consisting of 161 R-1 (2x) and 161 T-345 (2x)

161 T-1/4 062997

Pair of raster strips (front/rear) for transversal drawer partition

161 R-1/2 063000

Pair of raster strips (left/right) for longitudinal drawer partition

161 R-2/2 063017

Separation Sheet for 1/6 transversal drawer partition to be used with HAZET 161 R-1/2

161 T-85 063062

Separation Sheet for 1/4 transversal drawer partition to be used with HAZET 161 R-2/2

161 T-130 063055

Drawer Partition System

HAZET No.	EAN-No. 4000896+
Separation sheets for the new drawers (since 2000) with laterally integrated fixing devices, length 347 mm, height 60 mm	
161 T-172	063048
Separation Sheet for longitudinal drawer partition to be used with HAZET 161 R-1/2	
161 T-345	063024
Separation Sheet for transversal drawer partition to be used with HAZET 161 R-2/2	
161 T-522	063031

Drawer Insert

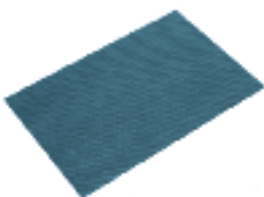

Anti-slip mat suitable for Assistent 168, 169 N, 174, 176 and 180 for anti-slipping storage of tools in the tool trolleys' drawers 348 x 523 mm

HAZET No.	EAN-No. 4000896+
161-1	058884

Tool Table

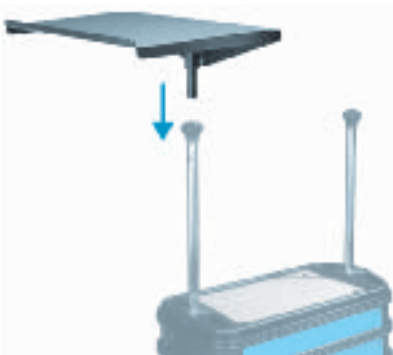

additional place of deposit for Tool Trolleys 162 N, 166 N, 162 C, 166 C e.g. for job instructions, etc.

HAZET No.	EAN-No. 4000896+
161-2	084531

Tool Trolleys



Cable Drum for Assistent 170-6, 173, 174, 176-1 and 180 as well as 169 N and 169 N-7 since 2004 with holding device, with 10 m cable, for Assistent without fixing device at the side panel – Export versions available –

HAZET No.	EAN-No. 4000896+
161-3 D	048878

Window Pane Holder



with rubber pads 65 mm ϕ , for Assistent 162 C, 162 N, 166 C, 166 N, 170-6, 171, 172 HD, 173-1, 176-1 and 180 **price apiece / to be used in pairs**

HAZET No.	EAN-No. 4000896+
161-8	004843



with mechanical suction swivel pads 120 mm ϕ , for Assistent 162 C, 162 N, 166 C, 166 N, 170-6, 171, 172 HD, 173-1, 176-1 and 180 **price apiece / to be used in pairs**

HAZET No.	EAN-No. 4000896+
161-9	004867



Tool Assortments



with Plastic Drawer Insert 161 PL, PUR foam inserts 854-1 PUR and 880-2 PUR for HAZET-Assistent 154-1, 155, 162 C, 162 N, 166 C, 166 N, 168, 169 N, 170-6, 173, 174, 176, 180 55 parts

Tool Assortment complete
contents:
850-4 5 6 7 8 9 10 11 12 13 14
8501-3 4 5 6 8
8503-0,6x3,5 0,8x4 1x5,5 1,2x8
8506-PH1 PH2 PH3 PH4
8507-PZ1 PZ2 PZ3
863 P 865 866 U 867-2 868 869
880-6 7 8 9 10 11 12 13 14
15 16 17 18 19 20 21 22
8815 8816 P 8820 8821-3 6

HAZET No.	EAN-No. 4000896+
161 P/55	004898
Plastic insert, empty	
161 PL	004911
PUR foam insert, empty for 854-1 854 T	
854-1 PUR	038367
880-2 PUR	039074

Tool Assortments

6.3 1/4" 12.5 1/2"



like 161 P/55, but with PUR foam inserts 854-1 PUR and 900 PUR 58 parts

Tool Assortment complete

contents:
850-4 5 6 7 8 9
10 11 12 13 14
863 P 865 866 U
867-2 868 869
8501-3 4 5 6 8
8503-0,6x3,5 0,8x4 1x5,5 1,2x8
8506-PH1 PH2 PH3 PH4
8507-PZ1 PZ2 PZ3
900-10 11 12 13 14 15 16
17 18 19 20 21 22 23
24 26 27 28 30 32
915 916 SP 917-5 918-10 920

HAZET No.	EAN-No. 4000896+
161 P/58	004904
Plastic insert, empty	
161 PL	004911
PUR foam insert, empty	
900 PUR	044078
854-1 PUR	038367

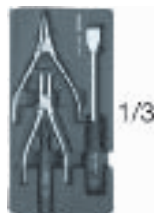

4 parts
Tool Assortment complete

contents:
823 824
1846 a-2 1846 c-2

HAZET No.	EAN-No. 4000896+
161-22 P/4	004508
Plastic insert, empty	
161-22 PL	004515



3 parts
Tool Assortment complete

contents:
760 N-2
1802-22 1841 a-22

HAZET No.	EAN-No. 4000896+
161-23 P/3	004522
Plastic insert, empty	
161-23 PL	004539

Tool Assortments

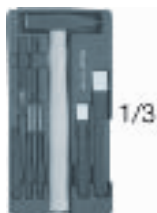

8 parts
Tool Assortment complete

contents:
730-3 6 746-1 748 b-3 4 5 6
2140-5

HAZET No.	EAN-No. 4000896+
161-24 P/8	004546

Plastic insert, empty

161-24 PL	004553
-----------	--------



3 parts
Tool Assortment complete

contents:
757-7 10
1952-35

HAZET No.	EAN-No. 4000896+
161-25 P/3	004560

Plastic insert, empty

161-25 PL	004577
-----------	--------

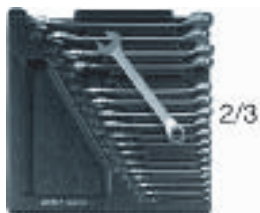

18 parts
Tool Assortment complete

contents:
603-6 7 8 9 10 11
12 13 14 15 16 17
18 19 21 22 24 27

HAZET No.	EAN-No. 4000896+
161-26 P/18	004584

Plastic insert, empty

161-26 PL	004591
-----------	--------



11 parts
Tool Assortment complete

contents:
450 N-6 x 7 8 x 9 10 x 11 12 x 13
14 x 15 16 x 17 18 x 19 21 x 22
24 x 27 30 x 32 34 x 36

HAZET No.	EAN-No. 4000896+
161-27 P/11	004607

Plastic insert, empty

161-27 PL	004614
-----------	--------

Tool Assortments



17 parts
Tool Assortment complete

contents:
600 N-6 7 8 9 10 11 12 13 14
15 16 17 18 19 21 22 24

HAZET No.	EAN-No. 4000896+
161-28 P/17	004621

Plastic insert, empty

161-28 PL	004638
-----------	--------

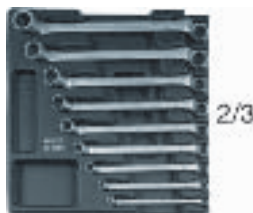

9 parts
Tool Assortment complete

contents:
630-6 x 7 8 x 9 10 x 11 12 x 13 14 x 15
16 x 17 18 x 19 20 x 22 21 x 23

HAZET No.	EAN-No. 4000896+
161-29 P/9	004645

Plastic insert, empty

161-29 PL	004652
-----------	--------

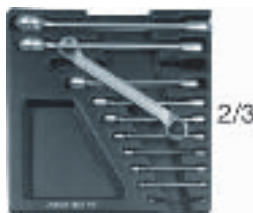

11 parts
Tool Assortment complete

contents:
610 N-6 x 7 8 x 9 10 x 11 12 x 13
14 x 15 16 x 17 18 x 19 21 x 22
24 x 26 27 x 32 30 x 34

HAZET No.	EAN-No. 4000896+
161-31 P/11	004683

Plastic insert, empty

161-31 PL	004690
-----------	--------

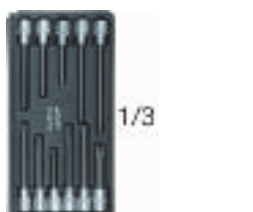

11 parts
Tool Assortment complete

contents:
986 Lg-5 7 10 986 SLg-6 8
990 Lg-8 990 SLg-10 12
992 Lg-T70 992 SLg-T45 T55

HAZET No.	EAN-No. 4000896+
161-32 P/11	053995

Plastic insert, empty

161-32 PL	053926
-----------	--------

Tool Assortments



4 parts
Tool Assortment complete

contents:
1846 a-2 1846 b-2
1846 c-2 1846 d-2

HAZET No.	EAN-No. 4000896+
161-35 P/4	053988

Plastic insert, empty

161-35 PL	053957
-----------	--------



8 parts
Tool Assortment complete

contents:
620-6 x 7 8 x 9 10 x 11 12 x 13
14 x 15 16 x 18 17 x 19 21 x 22

HAZET No.	EAN-No. 4000896+
161-36 P/8	057047

Plastic insert, empty

161-36 PL	057030
-----------	--------



8 parts
Tool Assortment complete

contents:
621-6 x 7 8 x 9 10 x 11
12 x 13 14 x 15 16 x 18
17 x 19 21 x 22

HAZET No.	EAN-No. 4000896+
161-37 P/8	057023

Plastic insert, empty

161-37 PL	057016
-----------	--------

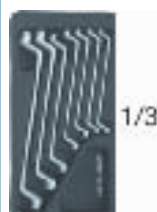

7 parts
Tool Assortment complete

contents:
630-E 4 x E 5 E 6 x E 7 E 8 x E 10
E 11 x E 12 E 14 x E 16 E 18 x E 20
E 22 x E 24

HAZET No.	EAN-No. 4000896+
161-38 P/7	059546

Plastic insert, empty

161-38 PL	059539
-----------	--------



Tool Assortments



1/3

8 parts
Tool Assortment complete
 contents:
 630-6x 7 8x 9 10x11 12x13
 14x15 16x17 18x19 21x22

HAZET No.	EAN-No. 4000896+
161-39 P/8	059522
Plastic insert, empty	
161-39 PL	059515



1/3

7 parts
Tool Assortment complete
 contents:
 645-8x 9 10x11 12x13 14x15
 16x17 18x19 21x22

HAZET No.	EAN-No. 4000896+
161-40 P/7	060122
Plastic insert, empty	
161-40 PL	060115



1/3

10 3/8

22 parts
Tool Assortment complete
 contents:
 8801 K-3 4 5 6 7 8 9 10
 8802-T15 T20 T25 T27 T30 T40 T45 T50
 8808 Lg-8 10
 8808-5 6 8 10

HAZET No.	EAN-No. 4000896+
161-41 P/22	060948
Plastic insert, empty	
161-41 PL	060856



1/3

10 3/8

17 parts
Tool Assortment complete
 contents:
 880-10 11 12 13 14 15
 16 17 18 19 21 22
 8816P 8820 8821-3 6 10

HAZET No.	EAN-No. 4000896+
161-42 P/17	061273
Plastic insert, empty	
161-42 PL	060863

Tool Assortments



1/3

6.3 1/4

45 parts
Tool Assortment complete
 contents:
 850-4 5 5,5 6 7 8
 9 10 11 12 13 14
 850-E4 E 5 E 6 E7
 E8 E10 E11
 863 P 866U 867-2 868 869
 8501-3 4 5 6 8
 8502-T 8 T 9 T10 T15 T20
 T25 T27 T30 T40
 8503-0,6x3,5 1x5,5 1,2x8
 8506-PH1 PH2 8507-PZ1 PZ2

HAZET No.	EAN-No. 4000896+
161-43 P/45	060924
Plastic insert, empty	
161-43 PL	060870



1/3

12 5/8

13 parts
Tool Assortment complete
 contents:
 990 Lg-6 8 990 S Lg-10 12
 990-6 8 10 12
 992-T30H T40H T45H T50H T55H

HAZET No.	EAN-No. 4000896+
161-44 P/13	060917
Plastic insert, empty	
161-44 PL	060887

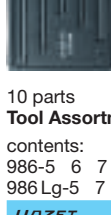

1/3

12 5/8

10 parts
Tool Assortment complete
 contents:
 986-5 6 7 8 10
 986 Lg-5 7 10 986 S Lg-6 8

HAZET No.	EAN-No. 4000896+
161-45 P/10	060900
Plastic insert, empty	
161-45 PL	060894

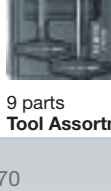

1/3

9 parts
Tool Assortment complete

Tool Assortments

contents:
 828-T6 T7 T8 T9 T10 T15 T20 T25 T30

HAZET No.	EAN-No. 4000896+
161-46 P/9	061976
Plastic insert, empty	
161-46 PL	061891



1/3

8 parts
Tool Assortment complete
 contents:
 828-2 2,5 3 4 5 6 8 10

HAZET No.	EAN-No. 4000896+
161-47 P/8	061983
Plastic insert, empty	
161-47 PL	061907



1/3

12 5/8

28 parts
Tool Assortment complete
 contents:
 900-12 17 18 19 20 21
 22 24 27 30 32
 900 Z-8 9 10 11 12 13 14
 15 16 17 18 19 30
 916 SP 917-5 918-10 920

HAZET No.	EAN-No. 4000896+
161-49 P/28	074235
Plastic insert, empty	
161-49 PL	073450



1/3

6.3 1/4

30 parts
Tool Assortment complete
 contents:
 850-4 5 5,5 6 7 8
 9 10 11 12 13 14
 8501-3 4 5 6 8
 8503-0,6x3,5 1x5,5 1,2x8
 8506-PH1 PH2
 8507-PZ1 PZ2
 863 P 865 866U
 867-2 868 869

HAZET No.	EAN-No. 4000896+
161-50 P/30	100835
Plastic insert, empty	
161-50 PL	095247

Tool Assortments



2/3



58 parts
Tool Assortment complete

- contents:
- 609-E 6xE 8 E10xE12 E14xE18 E20xE24
 - 803-T 6 T 7 T 8 T 9 T10 T15 T20 T25 T27 T30
 - 850-E4 E5 E6 E7 E8
 - 880-E10 E11 E12 E14
 - 8802-T40 T45
 - 900-E16 E18 E20 E24
 - 992-T50 T55 T60
 - 2115-T 6 T 7 T 8 T 9 T10 T15 T20 T25 T27 T30 T40
 - 2223-T6
 - 2223-T 7H T 8H T 9H T10H T15H T20H T25H T27H T30H T40H
 - 2223 Lg-T25
 - 2250-1 2 2264

HAZET No.	EAN-No. 4000896+
161-52 P/58	100842
Plastic insert, empty	
161-52 PL	095261



2/3

125 1/2

27 parts
Tool Assortment complete

- contents:
- 900-10 11 12 13 14 15 16 17 18 19 20 21 22 23 24 26 27 28 30 32 34
 - 915 916 SP 917-5
 - 918-10 920

HAZET No.	EAN-No. 4000896+
161-53 P/27	100859
Plastic insert, empty	
161-53 PL	095575



1/3

4 parts
Tool Assortment complete

- contents:
- 759 N-2
 - 1802 N-2 1841 N b-3 1850 N-2

HAZET No.	EAN-No. 4000896+
161-54 P/4	098491
Plastic insert, empty	
161-54 PL	098477

Tool Assortments



1/3

4 parts
Tool Assortment complete

- contents:
- 2119-8 2120-8 2122-8 2123-8

HAZET No.	EAN-No. 4000896+
161-56 P/4	098484
Plastic insert, empty	
161-56 PL	098460



1/3



4 parts
Tool Assortment complete

- contents:
- 428-7 8 10 13

HAZET No.	EAN-No. 4000896+
161-57 P/4	109265
Plastic Insert empty	
161-57 PL	109258



1/3

8 parts
Tool Assortment complete

- contents:
- 450 N-6x 7 8x 9 10x11 12x13 14x15 16x17 18x19 21x22

HAZET No.	EAN-No. 4000896+
450 N/8	020850
Plastic insert, empty	
450/8 PL	061761



1/3

8 parts
Tool Assortment complete

- contents:
- 600 N-10 11 13 14 15 17 19 22

HAZET No.	EAN-No. 4000896+
600 N/8	023387
Plastic insert, empty	
600 N/8 PL	057139

Screwdriver Sets



1/3



6 parts
Tool Assortment complete

- contents:
- 801-40 55 65 80 801-PH1 PH2

HAZET No.	EAN-No. 4000896+
801/6	080434
Plastic insert, empty	
801/6 PL	083190



1/3



5 parts
Tool Assortment complete

- contents:
- 801-T10H T15H T20H T25H T30H

HAZET No.	EAN-No. 4000896+
801 T H/5	080243
Plastic insert empty	
801 T H/5 PL	085743



1/3



6 parts
Tool Assortment complete

- contents:
- 803-40 55 65 80 803-PH1 PH2

HAZET No.	EAN-No. 4000896+
803/6	080373
Plastic insert, empty	
803/6 PL	083176



1/3



6 parts
Tool Assortment complete

- contents:
- 803-40 55 65 80 803-PZ1 PZ2

HAZET No.	EAN-No. 4000896+
803/6-1	080380
Plastic insert, empty	
803/6 PL	083176

Screwdriver Sets

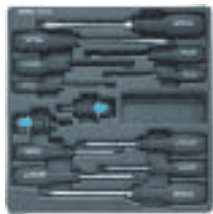

2/3



13 parts
Tool Assortment complete

contents:
801 K-55 801 K-PH 2
803-25 30 35 40 65 80
803-PZ 1 PZ 2
803-PH 1 PH 2 PH 3

HAZET No.	EAN-No. 4000896+
803/13	098514
Plastic insert, empty	
803/13 PL	098521



1/3



10 parts
Tool Assortment complete

contents:
803-25 30 35 40 65 80
803-PH 1 PH 2
801 K-55 801 K-PH 2

HAZET No.	EAN-No. 4000896+
803/10	080236
Plastic insert, empty	
803/10 PL	083183



1/3



6 parts
Tool Assortment complete

contents:
803 VDE-25 40 55 65
803 VDE-PH 1 PH 2

HAZET No.	EAN-No. 4000896+
803 VDE/6	080229
Plastic insert, empty	
810 VDE/6 PL	057146



1/12



- For inside hexagon screws
- □ Drive 12.5 = 1/2"
- In plastic drawer insert
- 5 parts

contents:
986-5 6 7 8 10

HAZET No.	EAN-No. 4000896+
986-P/5	054145
Plastic insert, empty	
2191-1 PL	054350

Screwdriver Socket Sets



2/12



- For inside hexagon screws
- □ Drive 12.5 = 1/2"
- With ball head
- In plastic drawer insert
- 6 parts

contents:
986 KK-5 6 7 8 10 12

HAZET No.	EAN-No. 4000896+
986 KK-P/6	054091
Plastic insert, empty	
2191-22 PL	054381



3/12



- For inside hexagon screws
- □ Drive 12.5 = 1/2"
- Long style
- In plastic drawer insert
- 5 parts

contents:
986 Lg-5 7 10
986 S Lg-6 8

HAZET No.	EAN-No. 4000896+
986 S Lg-P/5	054039
Plastic insert, empty	
2191-3 PL	054374



1/12



- For screws with internal serration (XZN)
- □ Drive 12.5 = 1/2"
- In plastic insert
- 5 parts

contents:
990-5 6 8 10 12

HAZET No.	EAN-No. 4000896+
990-P/5	054053
Plastic insert, empty	
2191-1 PL	054350



1/12



- For screws with internal serration (XZN)
- Long style
- □ Drive 12.5 = 1/2"
- In plastic insert
- 3 parts

contents:
990 Lg-8
990 S Lg-10 12

HAZET No.	EAN-No. 4000896+
990 S Lg-P/3	054046
Plastic insert, empty	
2191-11 PL	054367

Screwdriver Socket Sets



1/12



- For tamper resistant TORX® screws (Inside TORX® screws with pin)
- □ Drive 12.5 = 1/2"
- In plastic insert
- 5 parts

contents:
992-T 30 H T 40 H T 45 H T 50 H T 55 H

HAZET No.	EAN-No. 4000896+
992 H-P/5	054152
Plastic insert, empty	
2191-1 PL	013999

Tool Assortments



assortment with 77 parts
for car body work
see page 86

HAZET No.	EAN-No. 4000896+
0-1900/77	000241



assortment with 45 parts
for motorcycles
see page 107

HAZET No.	EAN-No. 4000896+
0-2450/45	000289

Tool Assortments



assortment with 100 parts
for VOLKSWAGEN-AUDI
see page 108

HAZET No.	EAN-No. 4000896+
0-2500/100	000296

Tool Assortments



assortment with 134 parts
for BMW motorcycles
see page 120

HAZET No.	EAN-No. 4000896+
0-2900/134	000395

Tool Assortments



assortment with 218 parts
for PORSCHE passenger cars
see page 123

HAZET No.	EAN-No. 4000896+
0-3300/218	057429



assortment with 117 parts
for MERCEDES-BENZ passenger cars
see page 114

HAZET No.	EAN-No. 4000896+
0-2700/117	000340

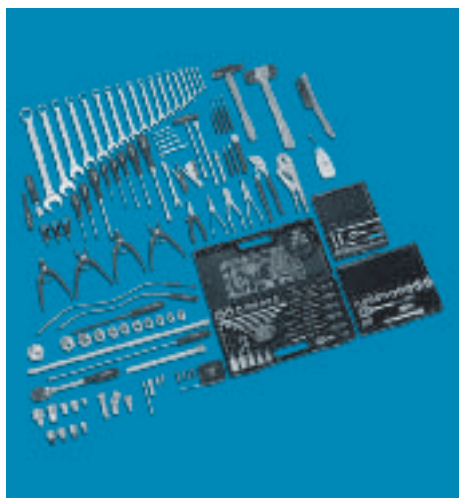

assortment with 204 parts
for BMW passenger cars
see page 120

HAZET No.	EAN-No. 4000896+
0-2900/204	079858



assortment with 80 parts
for FORD passenger cars
see page 123

HAZET No.	EAN-No. 4000896+
0-3400/80	000463



assortment with 137 parts
for MERCEDES-BENZ commercial vehicles
see page 114

HAZET No.	EAN-No. 4000896+
0-2700/137	000364

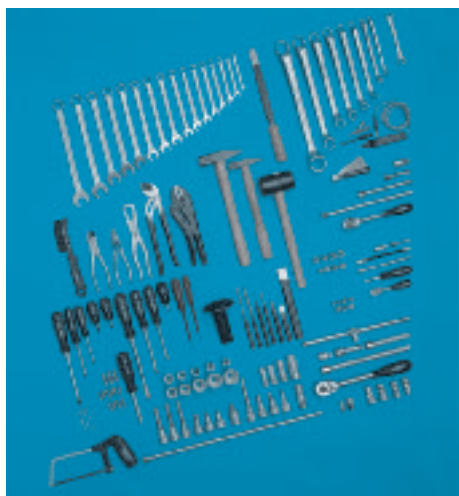

assortment with 141 parts
for OPEL passenger cars
see page 122

HAZET No.	EAN-No. 4000896+
0-3000/141	000449



assortment with 148 parts
for CHRYSLER
see page 124

HAZET No.	EAN-No. 4000896+
0-3550/148	058051

Tool Assortments



assortment with 44 parts
for CHRYSLER
see page 125

HAZET No.	EAN-No. 4000896+
0-3550/44	058068

Tool Assortments



assortment with 75 parts
for RENAULT passenger cars
see page 127

HAZET No.	EAN-No. 4000896+
0-3800/75	000494

Tool Assortments

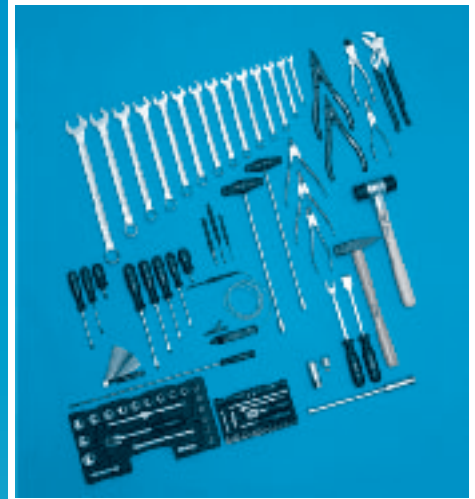

assortment with 100 parts
for NISSAN passenger cars
see page 128

HAZET No.	EAN-No. 4000896+
0-4370/100	058044



assortment with 95 parts
for FIAT passenger cars
see page 126

HAZET No.	EAN-No. 4000896+
0-3600/95	000470



assortment with 98 parts
for TOYOTA passenger cars
see page 127

HAZET No.	EAN-No. 4000896+
0-4320/98	000517



assortment with 50 parts
for HONDA passenger cars
see page 129

HAZET No.	EAN-No. 4000896+
0-4390/50	000548



assortment with 65 parts
for PEUGEOT passenger cars
see page 126

HAZET No.	EAN-No. 4000896+
0-3700/65	000487



assortment with 141 parts
for MAZDA passenger cars
see page 128

HAZET No.	EAN-No. 4000896+
0-4350/141	058037

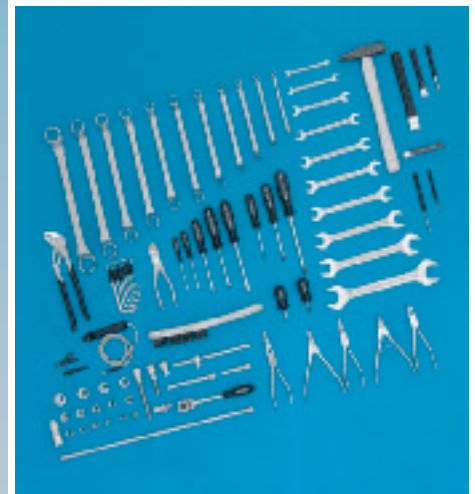

assortment with 81 parts
for MITSUBISHI passenger cars
see page 129

HAZET No.	EAN-No. 4000896+
0-4410/81	000555

Tool Assortment



especially for Tool Trolley 173
assortment with 193 parts



contents:

450N-6x 7 8x 9 10x11 12x13
14x15 16x17 18x19 21x22
600N-6 7 8 9 10 11 12 13 14
15 16 17 18 19 21 22 24
609-E6xE8 E10xE12 E14xE18 E20xE24
630-6x 7 8x 9 10x11 12x13
14x15 16x17 18x19 21x22
730-3 6 746-1
748B-3 4 5 6 760N-2
801K-55 PH2
803-25 30 35 40 65 80
803-PH1 PH2 PZ1 PZ2
803-T 6 T 7 T 8 T 9 T10
T15 T20 T25 T27 T30
823 824
850-4 5 5,5 6 7 8 9 10 11 12 13 14
850-E4 E5 E6 E7 E8
8501-3 4 5 6 8
8503-0,5x3,5 1x5,5 1,2x8
8506-PH1 PH2
8507-PZ1 PZ2
863P 865 866U
867-2 868 869
880-10 11 12 13 14 15
16 17 18 19 21 22
880-E10 E11 E12 E14
8802-T40 T45
8816P 8820
8821-3 6 10
900-10 11 12 13 14 15 16 17 18 19
20 21 22 23 24 26 27 28 30 32 34
900-E16 E18 E20 E24
992-T50 T55 T60
915 916SP 917-5 918-10 920
1802-22 1841 A-22
1846A-2 1846C-2
2115-T 6 T 7 T 8 T 9 T10 T15
T20 T25 T27 T30 T40
2140-5
2223 Lg-T25
2223-T 7H T 8H T 9H T10H T15H
T20H T25H T27H T30H T40H
2250-1 2 2264

HAZET
No.

EAN-No.
4000896+

0-9/193

110292

Tool Assortment

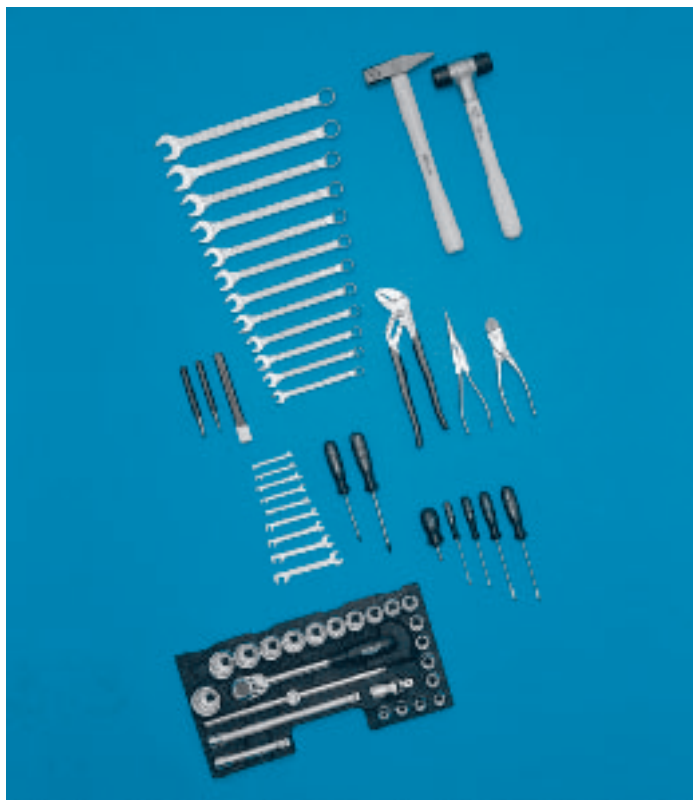

for motor-mechanics (passenger cars),
60 parts



contents:

440-4 4,5 5 5,5 6 7 8 10 11
600N-10 11 12 13 14 15
16 17 18 19 21 22
730-3 745a-2
746-2 760N-2
801 K-55
803-25 30 35 40
803-PH 1 PH 2
900-10 11 12 13 14 15 16 17
18 19 21 22 24 26 27 28
30 32 34
915 916SP 917-5
918-10 920
1802-2 1841 a-3 1952-35
2140-5

HAZET
No.

EAN-No.
4000896+

0-10/60

000050

Tool Assortment



for motor-mechanics (passenger cars),
100 parts

contents:

440-4 4,5 5 5,5 6 7 8 10 11
600N-10 11 12 13 14 15
16 17 18 19 21 22
630-6x 7 8x 9 10x11 12x13
14x15 16x17 18x19 21x22
730-3 745a-2 746-2
748b-3 4 760N-1 2
801K-55 801K-PH2
803-25 30 35 40
803-PH1 PH2
850-4 4,5 5 5,5 6 7 8
9 10 11 12 13 14
863P 864 865
866U 867-2 868 869
8816GK 8821-5
880KF 880AKF
900-10 11 12 13 14 15 16 17
18 19 21 22 24 26 27 28
30 32 34
915 916SP 917-5 918-10 920
1802-2 1841a-3
1952-35
2140-5 2147
4766-1



Tool Assortment

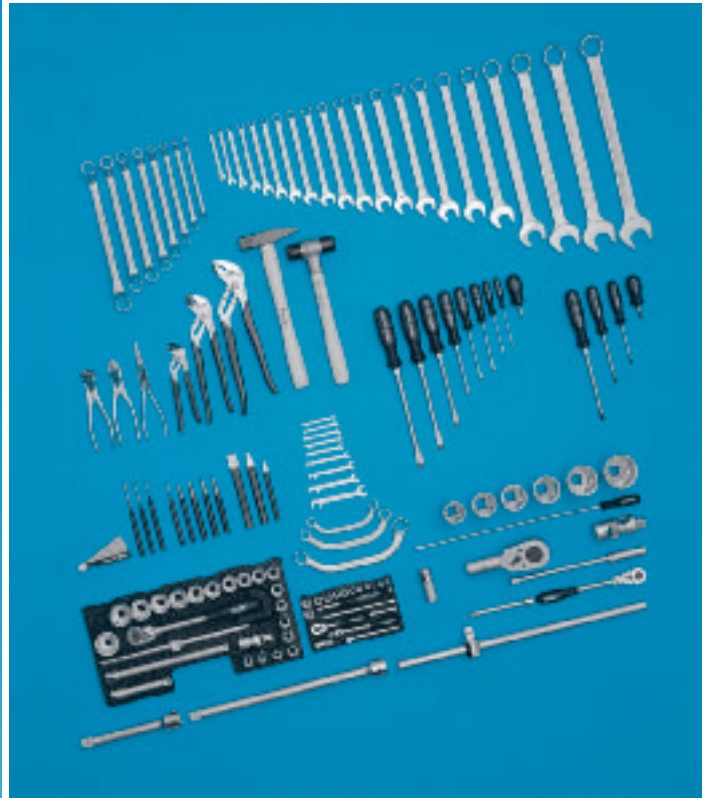

for motor-mechanics,
135 parts

contents:

440-4 4,5 5 5,5 6 7 8 10 11
600N-6 7 8 9 10 11 12
13 14 15 16 17 18 19
21 22 24 27 30 32 34
615-11x13 14x17 19x22
630-6x 7 8x 9 10x11 12x13
14x15 16x17 18x19 21x22
730-3 740-3 741-1
745a-2 3 5 746-1 2
748b-3 4 5 760N-1 2 3
801K-55 801K-PH2
803-25 30 35 40 55 80 100 120
803-PH1 PH2 PH3
850-4 4,5 5 5,5 6 7 8
9 10 11 12 13 14
863P 864 865
866U 867-2 868 869
880KF 8816GK 8821-5
900-10 11 12 13 14 15 16 17
18 19 21 22 24 26 27 28
30 32 34
915 916SP 917-5 918-10 920
1000-32 36 38 41 46 50
1014 1015-1 1016
1017-8 1018 1021
1802-2 1807-11
1841a-3
1952-35 1976-2
2140-5 2147
4766-1



HAZET
No.

EAN-No.
4000896+

0-10/100

000029

HAZET
No.

EAN-No.
4000896+

0-10/135

000036

Tool Assortment



for car body work,
75 parts

contents:
425-7 8 10
600N-8 9 10 11 12 13 14
15 16 17 18 19 21 22
630-8x10 13x15 17x19
650-20 652
731-5 745 a-6 745-4 746-1
757-10 12 758-1 2 760N-2
801-80 120
803-25 40 55
803-PH2 PH3 PZ2
821-1 824
900-10 13 14 15 17 19
916 SP 917-5
1802-2 1841 a-22
1917 N 1919 N 1920 N 1922
1925-1 1927 1928 K 1929-1
1930 1931 1932-1 1934
1937 K 1952-35 1960-5 1961 R-2
1962 N 1980 N
2122-10 2130 2140-5 8
2143 2150-2



Tool Assortment



for agricultural machinery,
71 parts

contents:
450 N-6x 7 8x 9 10x11 12x13 14x15
16x17 18x19 21x22 24x27 30x32
630-6x 7 8x 9 10x11 12x13 14x15 16x17
18x19 21x22 24x26 25x28 27x32 30x34
650-20 652
730-3 740-3
745 a-5 7 8
746-1 760N-2
803-25 55 80 120
820-3
900-10 11 12 13 14 15 16 17 18 19
21 22 24 26 27 28 30 32 34
915 916 SP 917-5 918-10 920
1000 Z-36 38 41 46
1014 1015-1 1017-8
1802-2
1976
2140-5 8



Tool Assortment



for industry,
95 parts

contents:

279-6 10
450N-6x 7 8x 9 10x11 12x13 14x15
16x17 18x19 21x22 24x27 30x32
630-6x 7 8x 9 10x11 12x13 14x15
16x17 18x19 21x22 24x27 30x32
730-3 6 740-3
745a-2 4 746-2
760N-1 2 3
803-25 30 35 40 55 80 100
803-PH1 PH2 PH3 PZ1 PZ2
850-4 4,5 5 5,5 6 7 8
9 10 11 12 13 14
863P 864 865 866 U
867-2 868 869
900-10 11 12 13 14 15 16 17 18 19
21 22 24 26 27 28 30 32 34
915 916SP 917-5 918-10 920
1802-2 1807-11 1841a-3
1952-35 1980N 1981
2140-5 2154-2



Tool Assortment

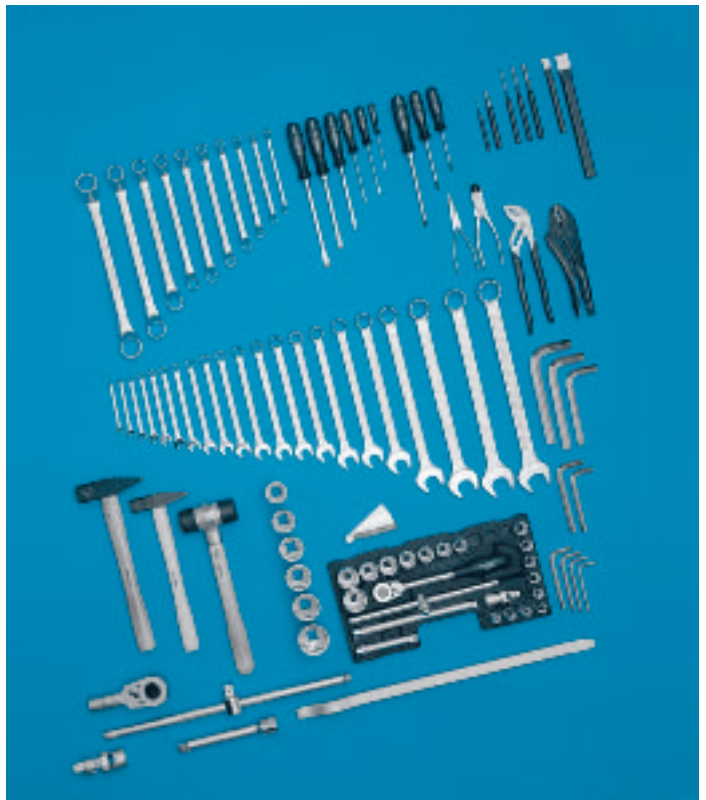

for commercial vehicles,
100 parts

contents:

600N-6 7 8 9 10 11 12 13 14 15 16
17 18 19 21 22 24 27 30 32 34
630-6x 7 8x 9 10x11 12x13 14x15
16x18 17x19 21x22 24x27 30x32
652
730-7 731-5 746-2
748a-2 748b-4 6 8
757-10 760N-2
803-25 35 40 55 80 100
803-PH1 PH2 PH3
900-10 11 12 13 14 15 16
17 18 19 21 22 24 26
27 28 30 32 34
915 916SP 917-5
918-10 920
1000-32 34 36 38 41 46
1014 1015-1 1016
1017-8 1021
1802-2 1841a-2
1952-50
2100-06 07 08 09 10 12 14 17 19
2140-5 10 2147



HAZET
No.

EAN-No.
4000896+

0-13/95

000128

HAZET
No.

EAN-No.
4000896+

0-15/100 N

000142

Tool Assortment

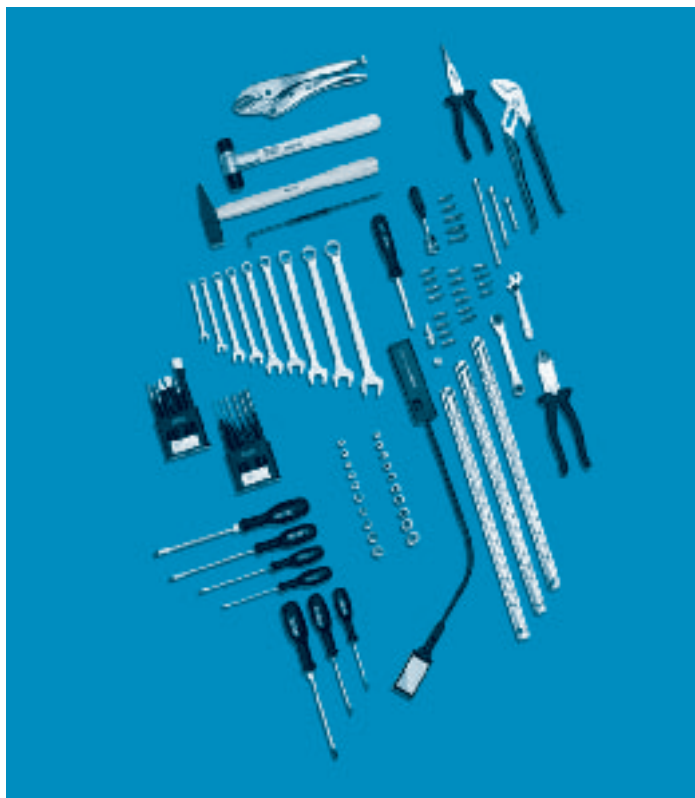

for aircraft and aerospace industry,

92 parts

contents:

279 V-4
 600 N A- $\frac{1}{4}$ $\frac{5}{16}$ $\frac{3}{8}$ $\frac{7}{16}$ $\frac{1}{2}$ $\frac{9}{16}$ $\frac{5}{8}$ $1\frac{1}{16}$ $\frac{3}{4}$
 731-2 5 741-1 745 a-4
 745-3 746-1
 748 a-2 3 748 b-4 5 748 c-6 8
 757-10 760 N-2
 803-40 55 65 80
 803-PH 1 PH 2 PH 3
 821-2
 850 AZ- $\frac{3}{16}$ $\frac{7}{32}$ $\frac{1}{4}$ $\frac{9}{32}$ $\frac{5}{16}$ $1\frac{1}{32}$ $\frac{3}{8}$ $\frac{7}{16}$ $\frac{1}{2}$ $\frac{9}{16}$
 850 TAZ- $\frac{3}{16}$ $\frac{7}{32}$ $\frac{1}{4}$ $\frac{9}{32}$ $\frac{5}{16}$ $1\frac{1}{32}$ $\frac{3}{8}$ $\frac{7}{16}$ $\frac{1}{2}$ $\frac{9}{16}$
 850 HL 858-1 863 S
 867-2 4 868 869
 1802-33 1841 A-33
 1952-35 1977-1
 2140-3 2150
 2208-4 6 8 9
 2213-0 1 2 3 4 5 6
 2215-PH 1 PH 2 PH 3 PH 4
 2221-0 1 2 3 4 5 6 8 10
 2250-3 2255 2265-1



Tool Assortment

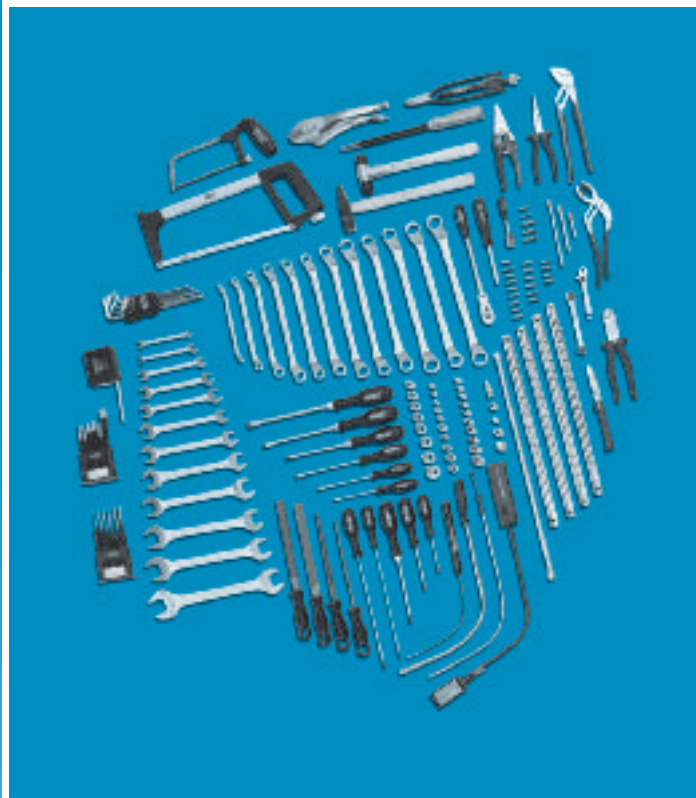

for aircraft and aerospace industry,

151 parts

contents:

279 V-4
 450 N A- $\frac{1}{4}$ x $\frac{5}{16}$ $\frac{5}{16}$ x $\frac{3}{8}$ $\frac{3}{8}$ x $\frac{7}{16}$ $\frac{1}{2}$ x $\frac{9}{16}$
 $\frac{9}{16}$ x $\frac{5}{8}$ $1\frac{9}{32}$ x $1\frac{1}{16}$ $\frac{5}{8}$ x $\frac{3}{4}$ $2\frac{5}{32}$ x $\frac{7}{8}$
 $\frac{7}{8}$ x $1\frac{9}{16}$ $1\frac{9}{16}$ x 1 1x $1\frac{1}{8}$ $1\frac{1}{16}$ x $1\frac{1}{4}$
 630 A- $\frac{1}{4}$ x $\frac{5}{16}$ $\frac{3}{8}$ x $\frac{7}{16}$ $\frac{1}{2}$ x $\frac{9}{16}$ $1\frac{9}{32}$ x $1\frac{1}{16}$
 $\frac{5}{8}$ x $1\frac{1}{16}$ $\frac{5}{8}$ x $\frac{3}{4}$ $\frac{3}{4}$ x $2\frac{5}{32}$ $\frac{3}{4}$ x $\frac{7}{8}$
 $2\frac{5}{32}$ x $1\frac{9}{16}$ $1\frac{9}{16}$ x $\frac{7}{8}$ $\frac{7}{8}$ x $1\frac{9}{16}$ $1\frac{9}{16}$ x 1
 731-2 5 741-1
 745 a-4 745-3 746-1
 748 a-2 3 748 b-4 5 748 c-6 8
 757-10 760 N-2
 803-40 55 65 80 100 120
 803-PH 1 PH 2 PH 3
 803 Lg-PH 1 PH 2
 821-2
 850 AZ- $\frac{3}{16}$ $\frac{7}{32}$ $\frac{1}{4}$ $\frac{9}{32}$ $\frac{5}{16}$ $1\frac{1}{32}$ $\frac{3}{8}$ $\frac{7}{16}$ $\frac{1}{2}$ $\frac{9}{16}$
 850 TAZ- $\frac{3}{16}$ $\frac{7}{32}$ $\frac{1}{4}$ $\frac{9}{32}$ $\frac{5}{16}$ $1\frac{1}{32}$ $\frac{3}{8}$ $\frac{7}{16}$ $\frac{1}{2}$ $\frac{9}{16}$
 850 HL 858-1 863 S
 867-2 4 868 869
 880 AZ- $\frac{3}{8}$ $\frac{7}{16}$ $\frac{1}{2}$ $\frac{9}{16}$ $1\frac{9}{32}$ $\frac{5}{8}$ $1\frac{1}{16}$ $\frac{3}{4}$ $\frac{7}{8}$
 880 HL 8816 G 8821-20 8858-1
 1802-33 1811-250 1815-230 1841 A-33
 1952-35 1975 1976
 1977-1 1978-1 1980 N 1981
 2105 A Lg-0.05" $\frac{1}{16}$ $\frac{5}{64}$ $\frac{3}{32}$ $\frac{1}{8}$ $\frac{5}{32}$ $\frac{3}{16}$ $\frac{7}{32}$ $\frac{1}{4}$ $\frac{5}{16}$
 2119-8 2120-8 2122-8 2123-8
 2140-3 2150 2154-5
 2156 2158
 2208-4 6 8 9
 2213-0 1 2 3 4 5 6
 2215-PH 1 PH 2 PH 3 PH 4
 2221-0 1 2 3 4 5 6 8 10
 2250-3 2255 2265-1



Tool Assortment



for electricians,

18 parts

contents:

803 VDE-25 35 40 55 65

803 VDE-PH0 PH1 PH2

839-1

1803 VDE-33 1816 VDE-22

1826 VDE-22 1841 a VDE-22 1841 b VDE-33

1850 VDE-22

1862

2154 2156-1



HAZET
No.

EAN-No.
4000896+

0-20/18

000265

Mobile Tool Case



- Lift-out extension allows ergonomical working at a practical height (600 mm)
- Special safety system provides tilt resistance (up to a total weight of 40 kg)
- Telescopic – one-handed transport and lift-out
- Deposit place and worktop in the opened case through cover plate on the inside of the lid

Mobile Tool Case

- Additional tray can be attached to the extended handle (loading capacity 3 kg max.)
- Additional space with modular partition and cover in the undercarriage
- Well-arranged tool storage for fast access
- 2-coloured tool inserts in the lid for safe tool storage – missing tools are noticed immediately
- Sturdy castors
- Integrated sliding rail in the back of the case for the transport over stairs

84 parts

contents:

600N-7 8 9 10 11 12 13 14
15 16 17 18 19 21 22

730-4 760N-2

801-30 40 55 65

801-PH1 PH2 PZ1 PZ2

801 K-PH2

824-1 839-1

850-6 7 8 9 10 11 12 13

863 F 863 Q 868 869

880-10 11 12 13 14 15 16

17 18 19 20 21 22

8802-T20 T25 T30

8815 8820 8816 P 8821-6 10

1802-2 1841 A-3 1961 R-1

1976-2 1979-20 1981

2100-02 025 03 04 05 06 08

2115-T8 T10 T15 T20 T25 T30 T40

2140-5 2154-2 2158

HAZET
No.

EAN-No.
4000896+

150/84

110971

Case, empty with soft foam insert

150 L

110988

Tool Assortments



HAZET
No.

EAN-No.
4000896+

contents:

450 N-6x 7 8x 9 10x11 12x13 14x15
16x17 18x19 21x22 24x27 30x32

630-6x 7 8x 9 10x11 12x13

14x15 16x17 18x19 21x22

730-3 740-3 745a-2 760 N-2

803-25 35 40 55

803-PH1 PH2 PZ1 PZ2

900-10 12 13 14 15 16 17 18 19

21 22 24 26 27 28 30 32

915 916SP 917-5 918-10 920

1802-2 1952-35

2140-5

190/55

048946

contents:

450 N-6x 7 8x 9 10x11 12x13 14x15

16x17 18x19 21x22 24x27 30x32

630-6x 7 8x 9 10x11 12x13 14x15

16x17 18x19 21x22 24x27 30x32

36x41

650-20

730-3 6 740-3 745a-2 4

746-2 760 N-1 2

803-25 30 35 40 55 80

803-PH1 PH2 PH3 PZ1 PZ2

824

900-10 11 12 13 14 15 16 17 18

19 21 22 24 26 27 28 30 32

915 916SP 917-5 918-10 920

986-5 6 8 10

1802-2 1841a-3 1952-35

2100-03 04 05 06 08 10

2140-5 2154

190/80

048922

Tool Assortment



without Tool Box, 55 parts,
contents see 190/55



HAZET No.	EAN-No. 4000896+
0-190/55	048953

Tool Box, empty



- 5 trays, with padlock,
- Sturdy design
- 530 x 200 x 200 mm
- Blue stove enamelling

HAZET No.	EAN-No. 4000896+
190 L	007462



without Tool Box, 80 parts,
contents see 190/80

HAZET No.	EAN-No. 4000896+
0-190/80	048939

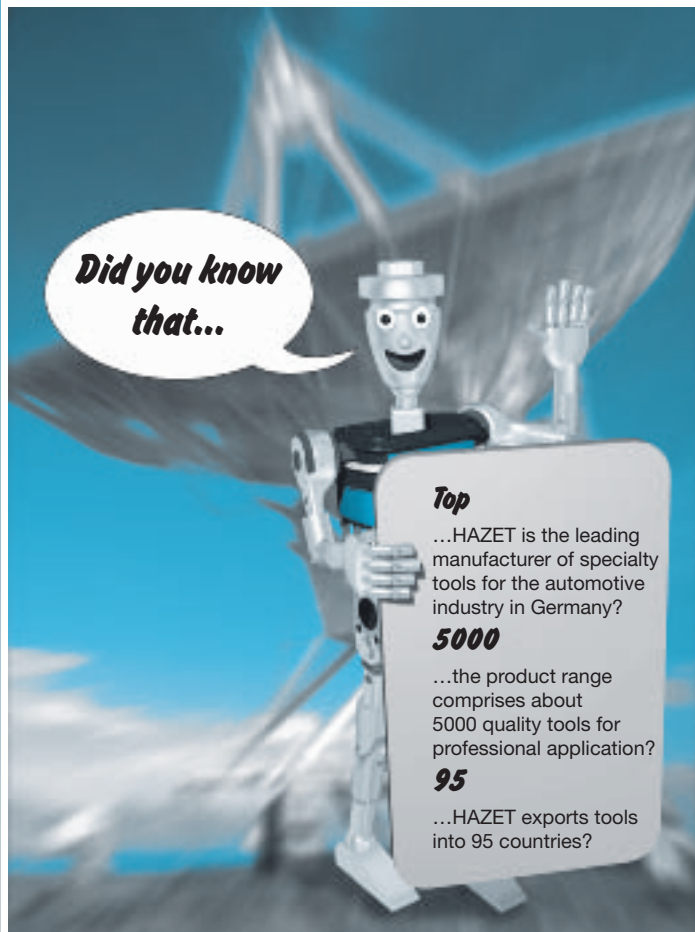

HAZET-Tools have well thought-out surfaces

- ✓ *Mat chrome-plated – the safest chrome plating, as it adheres to the steel in the best possible way*
- ✓ *Mat chrome-plated – greatest possible area of contact with the hand*
- ✓ *Mat chrome-plated – non-slipping in oily hands*
- ✓ *Mat chrome-plated – not dazzling*
- ✓ *Mat chrome-plated – looks unobtrusive and noble*
- ✓ *Mat chrome-plated – provides security to the user*

Adjustable Wrenches



- Head set at 15°
- With scale
- Chrome-Vanadium
- Surface phosphatized
- Mirror polished
- DIN 3117 form A, ISO 6787

HAZET No.	l mm	sb mm	EAN-No. 4000896+
279- 4	109	13	018086
279- 6	158	18	018093
279- 8	205	23	018109
279-10	255	28	018048
279-12	308	34	018055
279-15	382	43	018062
279-18	458	53	018079



- Head set at 22.5°
- With scale
- Chrome-Vanadium
- Surface chrome-plated
- Mirror polished
- DIN 3117 form B, ISO 6787

HAZET No.	l mm	sb mm	EAN-No. 4000896+
279 V- 4	109	13	018161
279 V- 6	158	18	018178
279 V- 8	205	23	018185
279 V-10	255	28	018147
279 V-12	308	34	018154

Hex Nut-Drivers



- Ergonomically shaped trinamic® handle
- Surface chrome-plated
- DIN 3125

Hex Nut-Drivers

HAZET No.	l ₁ mm	l ₂ mm	EAN-No. 4000896+
425-5	125	236	019083
425-5,5	125	236	019090
425-6	125	236	019106
425-7	125	236	019113
425-8	125	235	019120
425-9	125	235	019137

blade with hexagon bolster

HAZET No.	l ₁ mm	l ₂ mm	EAN-No. 4000896+
425-10	125	243	019014
425-11	125	243	019021
425-12	125	243	019038
425-13	125	243	019045

Flexible Hex Nut-Drivers

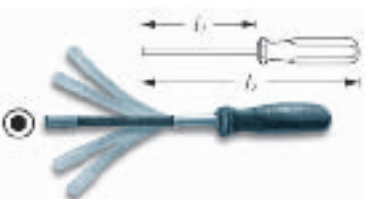

- e.g. for the hose clamps on radiator hoses
- Flexible blade
- Ergonomically shaped handle

HAZET No.	l ₁ mm	l ₂ mm	EAN-No. 4000896+
426- 5	190	300	019243
426- 6	190	300	019250
426- 7	190	300	019267
426- 8	190	300	019274
426-10	190	300	019236

Hex Nut-Drivers



- With T-handle
- Short style
- Chrome-Vanadium
- Surface chrome-plated

Hex Nut-Drivers

HAZET No.	l ₁ mm	l ₂ mm	EAN-No. 4000896+
428- 6	230	262	019397
428- 7	230	262	019410
428- 8	230	262	019427
428- 9	230	262	019441
428-10	230	262	019281
428-11	230	262	019304
428-12	230	265	019328
428-13	230	265	019335

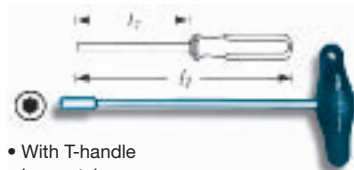

- With T-handle
- Long style
- Chrome-Vanadium
- Surface chrome-plated

HAZET No.	l ₁ mm	l ₂ mm	EAN-No. 4000896+
428 Lg- 8	350	382	019601
428 Lg-10	350	382	019526
428 Lg-11	350	382	019533
428 Lg-12	350	385	019540
428 Lg-13	350	385	019557
428 Lg-14	350	385	019564

6-Point Tubular Box Wrenches



- Bright heads
- Solid 6-point shank
- Chrome-Vanadium
- Forged from the solid
- Surface chrome-plated

HAZET No.	l mm	d ₁ mm	d ₂ mm	EAN-No. 4000896+
430- 6 x 7	115	9,5	10,5	019786
430- 8 x 9	120	11,8	13,0	019793
430-10 x 11	130	14,4	16,0	019649
430-12 x 13	140	17,0	18,4	019656
430-14 x 15	150	19,5	20,8	019663
430-16 x 17	160	21,8	23,0	019670
430-17 x 19	170	23,0	26,0	019687
430-18 x 19	170	24,4	26,0	019694
430-21 x 22	180	28,5	30,0	060375
430-24 x 27	190	32,2	36,0	019748
430-30 x 32	200	39,5	41,5	019779

6-Point Tubular Box Wrenches Sets



8 parts

contents:

430-6 x 7 8 x 9 10 x 11 12 x 13
14 x 15 16 x 17 18 x 19 21 x 22

HAZET No.	EAN-No. 4000896+
430/8	019823



435 x 215 x 62

- 12 parts
- In sturdy sheet metal box, blue
- With plastic insert

contents:

430-6 x 7 8 x 9 10 x 11 12 x 13 14 x 15
16 x 17 18 x 19 21 x 22 24 x 27 30 x 32
433-0619 2032

HAZET No.	EAN-No. 4000896+
430-1	019632

Pin Handles



- For 6-Point Tubular Box Wrenches
- Graduated
- Chrome-Vanadium
- Surface chrome-plated

HAZET No.	l mm	EAN-No. 4000896+
433-0619	250	019830
433-2032	280	019847

6-Point Offset Socket Wrenches

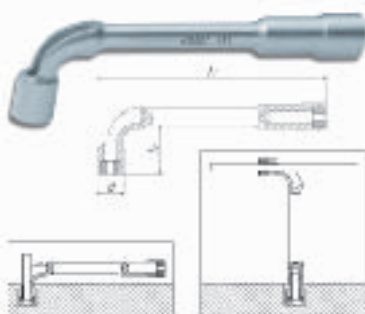

- To accommodate handle bars
- Both ends with 6-Point Socket
- With hole in the short offset end
- Solid
- Chrome-Vanadium
- Surface chrome-plated

HAZET No.	l ₁ mm	l ₂ mm	d mm	EAN-No. 4000896+
435- 6	95	17	10,0	076703
435- 7	100	19	11,0	076796
435- 8	110	24	12,0	076802
435- 9	115	25	13,0	076819
435-10	125	27	14,5	076826
435-11	130	29	16,5	076833

6-Point Offset Socket Wrenches

- To accommodate handle bars
- Both ends with 6-Point Socket
- With hole in the short offset end
- Solid
- Chrome-Vanadium
- Surface chrome-plated

HAZET No.	l ₁ mm	l ₂ mm	d mm	EAN-No. 4000896+
435-12	145	31	17,5	076840
435-13	160	34	19,0	076857
435-14	175	36	20,5	076864
435-15	180	38	21,5	076871
435-16	190	43	23,0	076888
435-17	195	44	24,5	076895
435-18	200	45	25,5	076901
435-19	210	48	27,0	076918
435-20	220	50	28,0	076925
435-21	229	51	29,5	076932
435-22	239	53	31,0	076949
435-23	245	58	32,5	076956
435-24	255	60	33,5	076963
435-25	260	58	35,0	076970
435-26	265	58	36,5	076987
435-27	275	63	37,0	076994
435-28	285	63	39,0	077007
435-29	295	63	40,0	077014
435-30	305	75	41,0	077021
435-32	330	75	44,0	077038

Offset Socket Wrench Set

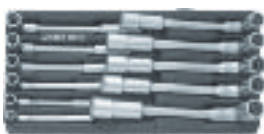

- 11 parts
- In HAZET plastic drawer insert

contents:

435-8 10 11 12 13 14 15 16 17 18 19

HAZET No.	EAN-No. 4000896+
435/11	079551
435/11 PL	079797

Double Open End Wrenches



- For areas with restricted access
- Heads set at 15° and 75° (same sizes)
- Short, thin style
- Chrome-Vanadium
- Surface chrome-plated

HAZET No.	l mm	a mm	b mm	EAN-No. 4000896+
440-3,2	70	2	10,5	020119
440- 3,5	70	2	10,5	020126
440- 4	70	2	10,5	020133
440- 4,5	70	2	10,5	020140
440- 5	78	2	12,6	020157
440- 5,5	78	2	12,6	020164
440- 6	78	2	12,6	020171
440- 7	91	2	14,7	020188
440- 8	96	3	16,8	020195
440- 9	103	3	18,9	020201
440-10	105	3	21,0	020065
440-11	116	3	24,2	020072
440-12	116	3	24,2	020089
440-13	131	3	28,3	020096
440-14	131	3	28,3	020102

Double Open End Wrenches Set



- 15 parts
- In plastic roll

contents:

440-3,2 3,5 4 4,5 5 5,5 6
7 8 9 10 11 12 13 14

HAZET No.	EAN-No. 4000896+
440/15 P	020232

Double Open End Wrenches



- For powerful use
- Slim heads
- Shank with sturdy double-T-profile
- Chrome-Vanadium
- Surface chrome-plated
- DIN 3110, ISO 10102

HAZET No.	l mm	a ₁ , a ₂ mm	EAN-No. 4000896+
450 N- 4 x 5	99,5	3,2	020683
450 N- 5 x 5,5	99,6	3,6	020706
450 N- 6 x 7	121,3	3,5	020713
450 N- 7 x 8	129,9	3,8	020720
450 N- 8 x 9	139,0	3,8	020744
450 N- 8 x 10	140,1	4,1	020737
450 N-10 x 11	155,7	4,6	020355
450 N-10 x 13	172,0	5,1	020362
450 N-12 x 13	172,7	5,1	020386
450 N-12 x 14	175,0	5,1	053902
450 N-13 x 14	187,8	5,7	020393
450 N-13 x 15	188,2	5,7	020409
450 N-13 x 17	205,5	6,0	020423
450 N-14 x 15	187,8	5,7	020430
450 N-16 x 17	205,7	6,0	020454
450 N-16 x 18	205,7	6,0	020461
450 N-17 x 19	220,9	6,7	020478
450 N-18 x 19	221,2	6,7	020485
450 N-19 x 22	237,5	7,0	020508
450 N-20 x 22	238,9	7,0	020515
450 N-21 x 22	238,0	7,0	020522
450 N-21 x 23	246,0	7,1	020539
450 N-22 x 24	254,6	7,1	020553
450 N-24 x 26	269,4	7,8	020560
450 N-24 x 27	269,0	7,8	020577
450 N-25 x 28	284,2	8,4	020584
450 N-27 x 30	303,8	9,0	020591
450 N-27 x 32	303,8	9,1	020607
450 N-30 x 32	303,4	9,0	020614
450 N-32 x 36	343,2	10,1	020638
450 N-34 x 36	343,2	10,1	020645
450 N-36 x 41	396,7	10,5	020652
450 N-41 x 46	439,5	11,4	020669
450 N-46 x 50	498,0	12,3	020676

Double Open End Wrenches Sets



Double Open End Wrenches Sets

* = in HAZET plastic drawer insert

HAZET No.	EAN-No. 4000896+			
8 parts				
contents:				
450 N-6 x 7	8 x 9	10 x 11	12 x 13	
14 x 15	16 x 17	18 x 19	21 x 22	
450 N/8 *	020850			
9 parts				
contents:				
450 N-6 x 7	8 x 9	10 x 11	12 x 13	14 x 15
17 x 19	21 x 22	24 x 27	30 x 32	
450 N/9	020874			
10 parts				
contents:				
450 N-6 x 7	8 x 9	10 x 11	12 x 13	14 x 15
16 x 17	18 x 19	21 x 22	24 x 26	27 x 32
450 N/10	020751			
12 parts				
contents:				
450 N-6 x 7	8 x 9	10 x 11	12 x 13	
14 x 15	16 x 17	18 x 19	20 x 22	
21 x 23	24 x 26	25 x 28	27 x 32	
450 N/12	020775			

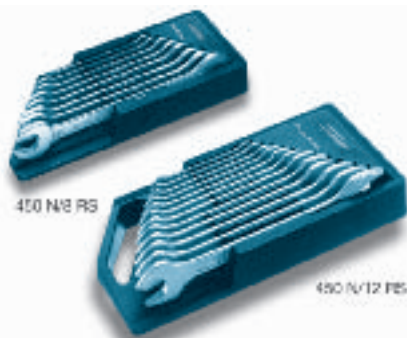

- In stable plastic clips
- Suitable for wall fixation
- Sets with 12 parts with practical carrying handle

HAZET No.	EAN-No. 4000896+			
8 parts				
contents:				
450 N-6 x 7	8 x 9	10 x 11	12 x 13	
14 x 15	16 x 17	18 x 19	21 x 22	
450 N/8 RS	020867			
12 parts				
contents:				
450 N-6 x 7	8 x 9	10 x 11	12 x 13	
14 x 15	16 x 17	18 x 19	20 x 22	
21 x 23	24 x 26	25 x 28	27 x 32	
450 N/12 RS	020812			
12 parts				
contents:				
450 N-6 x 7	8 x 9	10 x 11	12 x 13	
14 x 15	16 x 17	18 x 19	20 x 22	
21 x 23	24 x 27	25 x 28	30 x 32	
450 N/12 N RS	020805			



Double Open End Wrenches Sets

HAZET No.	EAN-No. 4000896+	
Clip, empty for 450 N/8 RS and 610 N/8 RS		
450 N/8 RS L	020294	
Clip, empty for 450 N/12 RS, 450 N/12 N RS, 610 N/12 RS		
450 N/12 RS L	020270	

Double Open End Wrenches



- American sizes
- Chrome-Vanadium
- Surface chrome-plated
- High-polished heads

HAZET No.		l mm	a mm	EAN-No. 4000896+	
450 N A-	$\frac{1}{4} \times \frac{5}{16}$	VKH	129,9	3,0	020911
450 N A-	$\frac{5}{16} \times \frac{3}{8}$	VKH	140,1	4,1	020973
450 N A-	$\frac{3}{8} \times \frac{7}{16}$	VKH	155,7	4,6	020966
450 N A-	$\frac{1}{2} \times \frac{9}{16}$	VKH	172,4	5,1	020904
450 N A-	$\frac{9}{16} \times \frac{5}{8}$	VKH	189,8	5,7	021000
450 N A-	$\frac{19}{32} \times \frac{11}{16}$	VKH	205,7	6,0	020935
450 N A-	$\frac{5}{8} \times \frac{3}{4}$	VKH	220,9	6,7	020980
450 N A-	$\frac{25}{32} \times \frac{7}{8}$	VKH	238,9	7,0	020959
450 N A-	$\frac{7}{8} \times \frac{15}{16}$	VKH	254,6	7,1	020997
450 N A-	$1 \frac{1}{16} \times 1$	VKH	269,4	7,8	020928
450 N A-	$1 \times 1 \frac{1}{8}$	VKH	284,2	8,4	020942
450 N A-1	$1 \frac{1}{16} \times 1 \frac{1}{4}$	VKH	303,8	9,0	020881
450 N A-1	$1 \frac{1}{8} \times 1 \frac{1}{2}$	VKH	343,2	10,1	020898

Double Open End Wrenches Sets



HAZET No.	EAN-No. 4000896+	
6 parts		
contents:		
450 N A-	$\frac{3}{8} \times \frac{7}{16}$	$\frac{1}{2} \times \frac{9}{16}$
	$\frac{5}{8} \times \frac{3}{4}$	$\frac{19}{32} \times \frac{11}{16}$
		$\frac{15}{16} \times 1$
450 N A/6 VKH	021024	
8teilig:		
contents:		
450 N A-	$\frac{1}{4} \times \frac{5}{16}$	$\frac{5}{16} \times \frac{3}{8}$
	$\frac{1}{2} \times \frac{9}{16}$	$\frac{19}{32} \times \frac{11}{16}$
	$\frac{25}{32} \times \frac{7}{8}$	$\frac{15}{16} \times 1$
450 N A/8 VKH	021031	

Double Open End Wrenches Sets

HAZET No.	EAN-No. 4000896+		
12 parts			
contents:			
450 N A-	$\frac{1}{4} \times \frac{5}{16}$	$\frac{5}{16} \times \frac{3}{8}$	$\frac{3}{8} \times \frac{7}{16}$
	$\frac{1}{2} \times \frac{9}{16}$	$\frac{9}{16} \times \frac{5}{8}$	$\frac{19}{32} \times \frac{11}{16}$
	$\frac{5}{8} \times \frac{3}{4}$	$\frac{25}{32} \times \frac{7}{8}$	$\frac{7}{8} \times \frac{15}{16}$
	$\frac{19}{16} \times 1$	$1 \times 1 \frac{1}{8}$	$1 \frac{1}{16} \times 1 \frac{1}{4}$
450 N A/12 VKH	021017		

Open End Wrenches Striking Face Pattern



- For excessive impact stress
- Special steel
- DIN 133

HAZET No.	l mm	a mm	b mm	EAN-No. 4000896+	
452- 27	180	16,0	56	021420	
452- 30	190	17,0	62	021437	
452- 32	190	17,0	62	021444	
452- 36	215	17,5	76	021451	
452- 41	235	18,5	86	021468	
452- 46	255	20,0	98	021475	
452- 50	275	21,0	105	021482	
452- 55	300	23,0	116	021499	
452- 60	320	24,5	128	021505	
452- 65	342	27,0	138	021512	
452- 70	375	30,0	154	021529	
452- 75	375	30,0	154	021536	
452- 80	408	34,0	174	021543	
452- 85	408	34,0	174	021550	
452- 90	445	38,0	194	021567	
452- 95	445	38,0	194	021574	
452-100	485	44,0	215	021376	

6-Point Sockets



- For nuts on long threaded bolts and rods
- Slim style for areas with restricted access
- **Special 24-point drive**
- Bored through
- Application in the automotive, industrial and sanitary sector e.g. for conveyer belt tensioning
- Chrome-Vanadium
- Surface chrome-plated
- DGBM – German registered utility model, EP

HAZET No.	l mm	EAN-No. 4000896+	
536-10	38	022632	
536-11	38	022649	
536-12	38	022656	
536-13	38	022663	
536-14	38	022670	
536-15	40	022687	
536-16	40	022694	
536-17	42	022700	
536-18	44	022717	
536-19	44	022724	
536-21	46	022731	
536-22	50	022748	
536-24	53	022755	

»Komposit« Reversible Ratchet



- For 6-Point Sockets mentioned on page 31
- For nuts on long threaded bolts and rods
- **Special 24-point drive**
- Light-weight
- One-hand change-over switch on handle
- Reliable „Komposit“-construction: shock-resistant plastic body, laid-in steel cover plates
- Application in the automotive, industrial and sanitary sector e.g. for conveyer belt tensioning
- DBG M – German registered utility model, EP

HAZET No.	l mm	EAN-No. 4000896+
536	275	022762
Repair kit consisting of ratchet wheel, pawl and 4 screws for 536		
536-01/6	-	082223

Extension



- For 6-Point Sockets 536
- For areas with restricted access
- **Special 24-point drive**
- Bored through for working on long threaded bolts and rods

HAZET No.	l mm	EAN-No. 4000896+
537-5	146	022779

Socket Set



344 x 186 x 56

- For nuts on long threaded bolts and rods
- Slim style for areas with restricted access
- Change-over switch on handle enables one-hand operation
- In black plastic box with PUR foam insert
- 15 parts

contents:
536-10 11 12 13 14 15 16
17 18 19 21 22 24
536 537-5

HAZET No.	EAN-No. 4000896+
536/15	077182

Combination Wrenches



- With Traction profile
- Slim, polished heads
- Shank with stable double-T profile
- Box end 15° offset
- Chrome-Vanadium
- Surface chrome-plated
- DIN 3113, Form A, ISO 3318, ISO 7738

* = not according to DIN

HAZET No.	l mm	a ₁ mm	a ₂ mm	EAN-No. 4000896+
600 N- 5,5 *	105,0	6,0	4,0	023288
600 N- 6	105,0	6,0	4,0	023295
600 N- 7 *	118,5	6,6	4,0	023301
600 N- 8 *	130,0	7,0	4,5	023318
600 N- 9 *	143,0	8,0	4,5	023325
600 N-10 *	154,5	8,0	5,0	023028
600 N-11 *	168,5	8,4	5,5	023035
600 N-12 *	180,5	9,0	5,5	023042
600 N-13	193,0	10,0	6,3	023059
600 N-14 *	204,5	10,0	6,5	023073
600 N-15	218,0	11,0	7,0	023080
600 N-16	230,5	11,4	7,0	023097
600 N-17	242,5	12,4	7,5	023103
600 N-18	255,0	13,0	8,0	023110
600 N-19	268,5	13,5	8,0	023127
600 N-20 *	279,5	13,5	8,5	023134
600 N-21	292,0	13,7	8,5	023141
600 N-22	304,5	14,0	8,5	023158
600 N-23 *	328,0	14,3	9,5	023165
600 N-24	328,0	14,7	9,5	023172
600 N-25 *	354,0	15,0	10,0	023189
600 N-26 *	354,0	15,5	10,0	023196
600 N-27	380,0	16,0	10,5	023202
600 N-28 *	380,0	16,5	11,0	023219
600 N-29	380,0	17,0	11,5	023226
600 N-30	405,5	17,5	12,2	023233
600 N-32	420,0	18,0	12,0	023240
600 N-34	432,0	19,0	13,0	023257
600 N-36	460,0	20,0	13,0	023264
600 N-41	500,0	20,6	14,0	023271

- Box end 10° offset
- DIN 3113 Form B, ISO 3318, ISO 7738

* = not according to DIN

HAZET No.	l mm	a ₁ mm	a ₂ mm	EAN-No. 4000896+
600 N-46	520,0	24,0	15,0	048564
600 N-50	560,0	26,0	16,5	048571
600 N-55	610,0	28,0	18,0	048588
600 N-60	660,0	31,0	20,0	048595
600 N-65 *	710,0	33,0	22,0	048601
600 N-70 *	760,0	35,0	24,0	048618
600 N-75 *	810,0	38,0	26,0	048625
600 N-80 *	860,0	41,0	28,0	048632



- American sizes
- Chrome-Vanadium
- Surface chrome-plated

Combination Wrenches

HAZET No.	l mm	a ₁ mm	a ₂ mm	EAN-No. 4000896+
600 N A-¼	105,0	6,0	4,0	023493
600 N A-⅜	130,0	7,0	4,5	023554
600 N A-½	154,5	8,0	5,0	023547
600 N A-⅝	168,5	8,4	5,5	023578
600 N A-¾	193,0	10,0	6,3	023486
600 N A-⅞	204,5	10,0	6,5	023592
600 N A-1	230,0	11,4	7,0	023561
600 N A-1¼	242,5	12,4	7,5	023509
600 N A-¾	268,0	13,5	8,0	023530
600 N A-1⅞	292,0	13,7	8,5	023516
600 N A-2	304,0	14,0	8,5	023585
600 N A-2¼	328,0	14,7	9,5	023523
600 N A-1	354,0	15,5	10,0	023400
600 N A-1⅞	380,0	16,0	10,5	023417
600 N A-1½	380,0	17,0	11,5	023448
600 N A-1¼	420,0	18,0	12,0	023431
600 N A-1⅞	432,0	19,0	13,0	023462
600 N A-1½	460,5	20,0	13,0	023455
600 N A-1½	486,0	20,5	13,7	023424
600 N A-1½	500,0	20,6	14,0	023479
600 N A-1⅞	520,0	24,0	15,0	024155
600 N A-2	560,0	26,0	16,5	024247
600 N A-2⅞	610,0	28,0	17,0	024254
600 N A-2½	660,0	31,0	20,0	024261

Combination Wrenches Sets

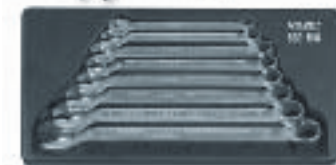

* = in HAZET plastic drawer insert

HAZET No.	EAN-No. 4000896+
8 parts	
contents: 600 N-10 11 13 14 15 17 19 22	
600 N/8 *	023387
12 parts	
contents: 600 N-10 11 12 13 14 15 16 17 18 19 21 22	
600 N/12 N	023332
17 parts	
contents: 600 N-7 8 9 10 11 12 13 14 15 16 17 18 19 21 22 24 27	
600 N/17 N	023349
21 parts	
contents: 600 N-6 7 8 9 10 11 12 13 14 15 16 17 18 19 21 22 24 27 30 32 34	
600 N/21	023356
30 parts	
contents: 600 N-5,5 6 7 8 9 10 11 12 13 14 15 16 17 18 19 20 21 22 23 24 25 26 27 28 29 30 32 34 36 41	
600 N/30	023363

Combination Wrenches Sets

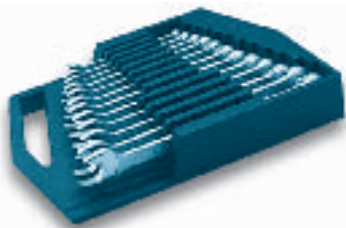

- 12 parts
- In sturdy plastic clip
- For wall fixation

contents:
600 N-10 11 12 13 14 15
16 17 18 19 21 22

HAZET No. EAN-No. 4000896+

600 N/12 RS 066636



Clip only

600/12 RS L 062324

American sizes

HAZET No. EAN-No. 4000896+

8 parts

contents:
600 N A- $\frac{3}{8}$ $\frac{7}{16}$ $\frac{1}{2}$ $\frac{9}{16}$ $\frac{5}{8}$ $\frac{3}{4}$ $\frac{7}{8}$ 1

600 N A/8-1 023622

10 parts

contents:
600 N A- $\frac{1}{4}$ $\frac{5}{16}$ $\frac{3}{8}$ $\frac{7}{16}$ $\frac{1}{2}$ $\frac{9}{16}$ $\frac{5}{8}$ $\frac{3}{4}$ $\frac{7}{8}$ 1

600 N A/10 023608

12 parts

contents:
600 N A- $\frac{1}{4}$ $\frac{5}{16}$ $\frac{3}{8}$ $\frac{7}{16}$ $\frac{1}{2}$ $\frac{9}{16}$ $\frac{5}{8}$ $\frac{3}{4}$ $\frac{7}{8}$
1 1 $\frac{1}{8}$ 1 $\frac{3}{16}$

600 N A/12-1 023615

Flexible Combination Wrenches

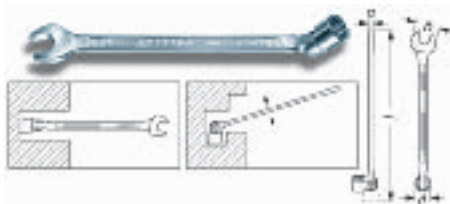

- Enables working on deeply located screws and in areas with restricted access
- Shank with stable and flexible 12-point socket
- Pivoting through 180°
- Slim and thin-walled
- Double-T-profile
- Equal span of jaw on both sides
- Chrome-Vanadium
- Surface chrome-plated

HAZET No. l mm a mm b mm d mm EAN-No. 4000896+

602-10 172 9,4 23,1 14,5 059089

602-11 189 10,0 25,3 16,0 059096

602-12 202 10,7 27,2 17,5 059102

602-13 217 14,8 29,1 19,0 059119

Flexible Combination Wrenches

HAZET No. l mm a mm b mm d mm EAN-No. 4000896+

602-14 230 11,6 30,9 20,0 059126

602-15 245 12,5 32,6 21,0 059133

602-16 257 13,4 34,7 23,0 059140

602-17 270 14,3 36,6 24,0 059157

602-18 283 15,5 38,6 25,0 059164

602-19 299 15,5 40,6 27,0 059171

602-21 324 16,5 44,6 29,0 059188

602-22 338 17,6 46,8 30,0 059195

Flexible Combination Wrenches Sets

HAZET No. EAN-No. 4000896+

4 parts

contents:
602-10 13 17 19

602/4 074136

12 parts

contents:
602-10 11 12 13 14 15
16 17 18 19 21 22

602/12 062980

Combination Wrenches

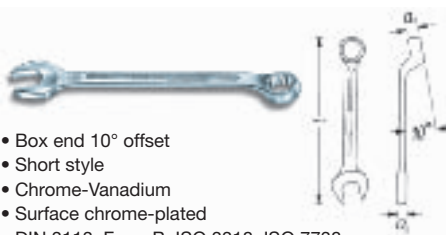

- Box end 10° offset
- Short style
- Chrome-Vanadium
- Surface chrome-plated
- DIN 3113, Form B, ISO 3318, ISO 7738

+ = box end with hexagon opening

HAZET No. l mm a₁ mm a₂ mm EAN-No. 4000896+

603- 5,5 + 90 4,7 3,7 023929

603- 6 + 100 5,1 4,0 023950

603- 7 + 110 5,5 4,3 023981

603- 8 + 120 5,9 4,5 024018

603- 9 + 130 6,3 4,5 024025

603-10 137 6,7 5,0 023691

603-11 145 7,1 5,2 023714

603-12 152 7,6 5,4 023721

603-13 160 8,0 5,6 023738

603-14 170 8,5 5,8 023752

603-15 180 9,0 6,0 023769

603-16 190 9,5 6,2 023776

603-17 200 10,0 6,4 023783

603-18 210 10,5 6,7 023790

603-19 220 11,0 7,0 023806

603-21 240 12,0 7,6 023820

603-22 250 12,5 7,9 023837

603-24 270 13,5 8,5 023844

603-27 305 15,0 9,3 023868

603-30 340 16,0 10,0 050260

603-32 360 17,0 10,5 023882

Combination Wrenches Sets



Combination Wrenches Sets

HAZET No. EAN-No. 4000896+

8 parts

contents:
603-10 11 13 14 15 17 19 22

603/8 024070

12 parts

contents:
603-10 11 12 13 14 15 16 17
18 19 21 22

603/12 N 024032

17 parts

contents:
603-7 8 9 10 11 12 13 14 15
16 17 18 19 21 22 24 27

603/17 N 024063



in plastic wall bracket

contents:
603-6 7 8 9 10 11 12
13 14 15 16 17 18 19
21 22 24

HAZET No. EAN-No. 4000896+

603/17 H 024049

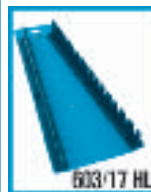

Holder, empty for 603/17 H

603/17 HL 024056

Combination Wrenches - Ratcheting



- Box-End Wrenches with ratchet function, reversible
- Fine tooth, 72 teeth, turning angle 5°
- Box-end side 13° offset
- Chrome-Vanadium
- Surface mat chrome-plated
- Heads polished

HAZET No. l mm a₁ mm a₂ mm EAN-No. 4000896+

606- 8 129,9 6,8 4,9 100941

606- 9 143,0 7,2 5,2 100958

606-10 154,5 7,6 5,6 100965

606-11 168,6 8,0 6,0 100972

606-12 180,3 8,5 6,4 100989

606-13 193,2 8,9 6,7 100996

606-14 204,6 9,3 7,1 101009

606-15 218,0 9,7 7,4 101016

606-16 230,2 10,2 7,7 101023

606-17 242,2 10,6 8,1 101030

606-18 255,0 11,0 8,5 101047

606-19 268,3 11,5 9,1 101054

TORX® Double Box-End Wrenches

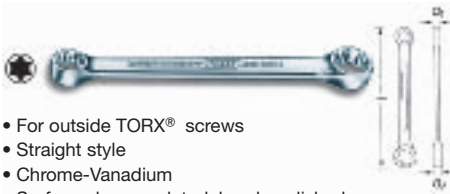

- For outside TORX® screws
- Straight style
- Chrome-Vanadium
- Surface chrome-plated, heads polished

HAZET No.	l mm	a ₁ mm	a ₂ mm	EAN-No. 4000896+
609-E 6 x E 8	113	4,8	5,8	024711
609-E 10 x E 12	140	6,8	8,0	024650
609-E 14 x E 18	180	7,9	9,5	024674
609-E 20 x E 24	224	11,0	13,0	024698

Double Box-End Wrenches



- New, modern design
- Ergonomically shaped with offset heads
- Shank with sturdy double-T profile
- Chrome-Vanadium
- Surface chrome-plated heads polished
- DIN 837, Form B, ISO 10103
- Protected by design patent

HAZET No.	l mm	a mm	EAN-No. 4000896+
610 N- 6 x 7	97,9	4,5	024940
610 N- 8 x 9	113,3	5,2	024957
610 N-10 x 11	125,3	6,0	024735
610 N-12 x 13	139,0	6,2	024742
610 N-13 x 15	152,7	7,5	024766
610 N-13 x 17	161,8	7,5	024773
610 N-14 x 15	154,5	7,0	024780
610 N-16 x 17	170,0	7,5	024797
610 N-16 x 18	177,2	8,5	024803
610 N-17 x 19	185,0	8,5	024810
610 N-18 x 19	188,6	8,5	024827
610 N-20 x 22	208,8	9,0	024834
610 N-21 x 22	232,3	10,0	024841
610 N-21 x 23	232,3	10,0	024858
610 N-22 x 24	234,5	10,5	024865
610 N-24 x 26	254,0	11,0	024872
610 N-24 x 27	267,1	11,0	024889
610 N-25 x 28	280,1	11,5	024896
610 N-27 x 32	308,7	13,0	024902
610 N-30 x 32	324,1	13,0	024919
610 N-30 x 34	326,7	14,0	024926
610 N-36 x 41	393,5	14,9	024933

Double Box-End Wrenches Sets



cardboard packed

HAZET No.	EAN-No. 4000896+
8 parts	
contents:	
610 N- 6 x 7	8 x 9 10 x 11 12 x 13
	14 x 15 16 x 17 18 x 19 21 x 22
610 N/8	024995

Double Box-End Wrenches Sets

HAZET No.	EAN-No. 4000896+
10 parts	
contents:	
610 N- 6 x 7	8 x 9 10 x 11 12 x 13 14 x 15
	16 x 17 18 x 19 21 x 22 24 x 27 30 x 32
610 N/10-1	024964
12 parts	
contents:	
610 N- 6 x 7	8 x 9 10 x 11 12 x 13
	14 x 15 16 x 17 18 x 19 20 x 22
	21 x 23 24 x 26 25 x 28 27 x 32
610 N/12	024971

Double Box-End Wrenches Sets

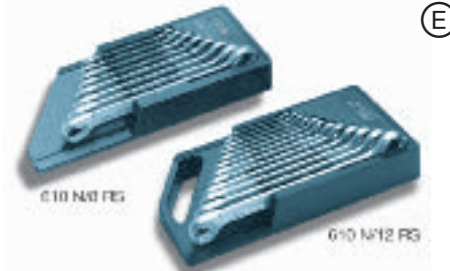

- In sturdy plastic clips
- Suitable for wall fixation
- Set 12 parts with practical carrying handle

HAZET No.	EAN-No. 4000896+
8 parts	
contents:	
610 N- 6 x 7	8 x 9 10 x 11 12 x 13
	14 x 15 16 x 17 18 x 19 21 x 22
610 N/8 RS	025008
12 parts	
contents:	
610 N- 6 x 7	8 x 9 10 x 11 12 x 13
	14 x 15 16 x 17 18 x 19 20 x 22
	21 x 23 24 x 26 25 x 28 27 x 32
610 N/12 RS	024988



Clip, empty for 450 N/8 RS and 610 N/8 RS

450 N/8 RS L	020294
--------------	--------

Clip, empty for 450 N/12 RS, 450 N/12 N RS, 610 N/12 RS

450 N/12 RS L	020270
---------------	--------

Flare Nut Wrenches



- For tube connections, union nuts and male fittings for pipes
- Heads bent 15°
- Slotted at 30° (12-point at 15°)
- Chrome-Vanadium
- Surface chrome-plated
- DIN 3118

Flare Nut Wrenches

Note: Wrenches for working on brake lines see HAZET 612 N

+ = with hexagon opening

HAZET No.	l mm	a ₁ mm	a ₂ mm	EAN-No. 4000896+
612- 8 x 10 +	140	7,0	8,0	025206
612-10 x 11 +	147	8,0	8,7	025091
612-11 x 13 +	160	8,7	9,8	025107
612-12 x 14 +	168	9,2	10,3	025114
612-13 x 15	182	9,8	10,9	025121
612-16 x 18	208	12,0	13,2	025145
612-17 x 19	208	12,0	13,2	025152
612-19 x 22	222	13,8	15,8	025169
612-24 x 27	260	16,2	18,0	025183
612-30 x 32	300	21,0	23,0	025190

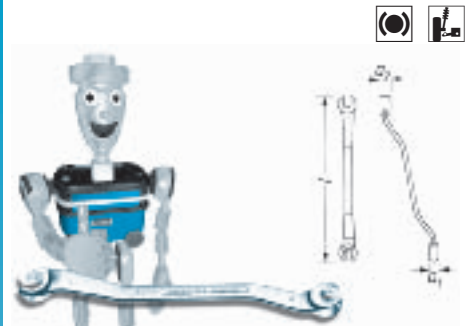

- For screwed connections on brake lines
- Reinforced design
- Offset
- With 6-point
- Straight slot
- Chrome-Vanadium
- Surface chrome-plated

HAZET No.	l mm	a ₁ mm	a ₂ mm	EAN-No. 4000896+
612 N- 8 x 9	157	10,0	10,0	025459
612 N-10 x 11	168	11,0	11,0	025428
612 N-11 x 13	184	11,5	11,5	025435
612 N-12 x 14	197	11,5	11,5	025442

Flare Nut Wrench Set

4 parts

contents:
612 N-8 x 9 10 x 11 11 x 13 12 x 14

HAZET No.	EAN-No. 4000896+
612 N/4	063925

Open Box-End Wrenches - Ratcheting



- For screwed connections in areas with restricted access
- Easy working due to ratcheting operation
- Open 12-point box wrench
- Flat design
- For hydraulic, pneumatic and other screwed connections, e.g. for brake lines and high-pressure lines
- Surface chrome-plated, heads burnished

HAZET No.	l mm	EAN-No. 4000896+
613- 8	137	062508
613-10	137	062515
613-11	137	062522
613-12	137	062539
613-13	137	062546
613-14	184	062553
613-17	184	082551

Open Box-End Wrench Set – Ratcheting

6 parts
in HAZET plastic drawer insert

HAZET No.	EAN-No. 4000896+
613/6	071388
Plastic insert, empty for 613/6	
613/6 PL	071333

Double Box-End Wrenches



(Starter and Block Wrench)

- Bent style
- Chrome-Vanadium
- Surface chrome-plated, heads polished

HAZET No.	l mm	EAN-No. 4000896+
615-11 x 13	145	025602
615-12 x 14	185	025619
615-13 x 15	185	025626
615-14 x 16	185	025633
615-14 x 17	185	025640
615-16 x 18	185	060382
615-17 x 19	235	050901
615-19 x 22	235	025664

Double Box-End Wrenches – Ratcheting



- With Traction profile
- Flat style
- Turn wrench to change operation direction from left to right and vice versa
- Special steel
- Surface bright chrome-plated

HAZET No.	l mm	EAN-No. 4000896+
620- 6 x 7	110	025732
620- 8 x 9	140	025749
620-10 x 11	175	025671
620-12 x 13	175	025688
620-14 x 15	205	025695
620-16 x 18	205	025701
620-17 x 19	205	025718
620-21 x 22	235	025725

Double Box-End Wrenches – Ratcheting Set

8 parts

contents:

620- 6 x 7 8 x 9 10 x 11 12 x 13
14 x 15 16 x 18 17 x 19 21 x 22

HAZET No.	EAN-No. 4000896+
620/8	056224

Double Box-End Wrenches – Ratcheting

- American sizes
- With Traction profile
- Flat style
- Special steel
- Surface bright chrome-plated

HAZET No.	l mm	EAN-No. 4000896+
620 A- 1/4 x 5/16	115	084647
620 A- 5/16 x 11/32	115	084654
620 A- 3/8 x 7/16	140	084661
620 A- 1/2 x 9/16	175	084678
620 A- 5/8 x 11/16	216	084685
620 A- 3/4 x 7/8	235	084692
620 A- 15/16 x 15/16	235	084708

TORX® Double Box-End Wrenches – Ratcheting



- For outside TORX® screws
- Turn wrench to change operation direction from left to right and vice versa
- Special steel
- Surface bright chrome-plated

HAZET No.	l mm	EAN-No. 4000896+
620-E 6 x E 7	114,0	058815
620-E 8 x E 10	140,0	058822
620-E 11 x E 12	140,0	058839
620-E 14 x E 16	174,5	058846
620-E 18 x E 20	206,5	058853
620-E 22 x E 24	235,0	058860

TORX® Double Box-End Wrenches - Ratcheting Set

6 parts

contents:

620-E 6 x E 7 E 8 x E 10 E 11 x E 12
E 14 x E 16 E 18 x E 20 E 22 x E 24

HAZET No.	EAN-No. 4000896+
620-E/6	058877

Double Box-End Wrenches – Ratcheting



- With Traction profile
- Reversible for operating to the right and to the left
- 25° offset
- Special steel
- Surface bright chrome-plated

HAZET No.	l mm	EAN-No. 4000896+
621- 6 x 7	110	025817
621- 8 x 9	140	025824
621-10 x 11	170	025756
621-12 x 13	170	025763
621-14 x 15	200	025770
621-16 x 18	200	025787
621-17 x 19	200	025794
621-21 x 22	230	025800

Double Box-End Wrenches – Ratcheting Set

8 parts

contents:

621- 6 x 7 8 x 9 10 x 11 12 x 13
14 x 15 16 x 18 17 x 19 21 x 22

HAZET No.	EAN-No. 4000896+
621/8	056217

Ratcheting Box-End Wrenches

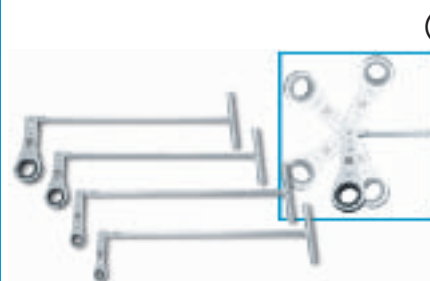

- With T-handle
- Especially suitable for areas with restricted access
- Pivoting, > 90°
- Extremely long

HAZET No.	l mm	EAN-No. 4000896+
622-10	375	102556
622-12	386	102563
622-13	386	102570
622-14	386	102587

Double Box-End Wrenches

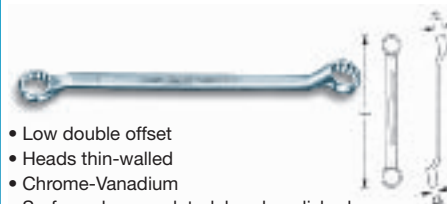

- Low double offset
- Heads thin-walled
- Chrome-Vanadium
- Surface chrome-plated, heads polished
- DIN 897, ISO 10104

HAZET No.	l mm	a ₁ mm	a ₂ mm	EAN-No. 4000896+
625- 6 x 7	129,5	7,0	7,0	025978
625- 8 x 9	149,4	7,5	7,5	025985
625-10 x 11	174,5	8,5	8,5	025848
625-12 x 13	199,5	9,5	9,5	025855
625-14 x 15	209,3	10,0	10,0	025862
625-16 x 18	244,5	12,0	12,0	025893
625-17 x 19	279,4	12,5	12,5	025909
625-21 x 22	329,0	14,0	14,0	025923

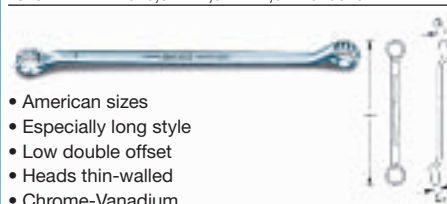

- American sizes
- Especially long style
- Low double offset
- Heads thin-walled
- Chrome-Vanadium
- Surface chrome-plated

HAZET No.	l mm	a ₁ mm	a ₂ mm	EAN-No. 4000896+
625 A Lg- 1/4 x 5/16	210	5,9	6,9	088171
625 A Lg- 5/16 x 3/8	225	7,0	7,4	088188
625 A Lg- 3/8 x 7/16	255	8,0	8,4	088195
625 A Lg- 7/16 x 1/2	265	8,8	8,9	088072
625 A Lg- 1/2 x 9/16	291	8,9	9,3	088201
625 A Lg- 9/16 x 5/8	314	9,8	10,8	088041
625 A Lg- 5/8 x 3/4	337	11,0	11,2	088218
625 A Lg- 11/16 x 3/4	391	11,9	12,3	088225



Double Box-End Wrenches



- Deep offset
- Heads thin-walled
- Chrome-Vanadium
- Surface chrome-plated, heads polished
- DIN 838, ISO 10104

+ = mat chrome-plated

HAZET No.	l mm	a ₁ mm	a ₂ mm	EAN-No. 4000896+
630- 6 x 7	165	6,0	6,5	026555
630- 8 x 9	180	7,0	7,5	026579
630- 8 x 10	180	7,0	8,0	026562
630-10 x 11	200	8,0	9,0	026227
630-10 x 12	205	8,0	9,0	053506
630-10 x 13	210	8,0	9,5	026234
630-12 x 13	220	9,0	9,5	026241
630-12 x 14	225	9,0	10,0	053490
630-13 x 14	230	9,5	10,0	026258
630-13 x 15	230	9,5	10,5	026265
630-13 x 16	245	9,5	11,0	026272
630-13 x 17	245	9,5	11,3	026289
630-14 x 15	240	10,0	10,5	026296
630-14 x 17	249	10,0	11,3	053483
630-16 x 17	255	11,0	11,3	026302
630-16 x 18	260	11,0	11,6	026319
630-17 x 19	265	11,3	11,9	026326
630-18 x 19	275	11,6	11,9	026333
630-18 x 21	295	11,6	12,5	026340
630-19 x 22	295	11,9	12,9	026357
630-20 x 22	295	12,2	12,9	026364
630-21 x 22	295	12,9	12,9	026371
630-21 x 23	315	12,5	13,2	026388
630-22 x 24	315	12,9	13,5	026395
630-24 x 26	330	13,5	14,1	026401
630-24 x 27	340	13,5	14,4	026418
630-24 x 30	340	13,5	15,4	026425
630-25 x 28	350	13,8	14,7	026432
630-27 x 32	365	14,4	16,0	026463
630-30 x 32	365	15,4	16,0	026470
630-30 x 34	400	15,4	17,0	026487
630-32 x 36	400	16,0	17,2	026494
630-36 x 41 +	440	17,2	18,8	026517
630-41 x 46 +	485	18,8	20,3	026524
630-46 x 50 +	515	20,3	21,6	026531

- American sizes
- Chrome-Vanadium
- Surface chrome-plated, heads polished
- ISO 1085

HAZET No.	l mm	a ₁ mm	a ₂ mm	EAN-No. 4000896+
630 A- 1/4 x 5/16	170	6,6	7,0	026722
630 A- 3/8 x 7/16	200	8,0	9,0	026807
630 A- 1/2 x 9/16	230	9,5	10,5	026715
630 A- 19/32 x 11/16	255	10,8	11,5	026753
630 A- 5/8 x 13/16	260	11,0	11,6	026814
630 A- 3/4 x 3/4	265	11,0	11,9	026821
630 A- 3/4 x 25/32	285	11,9	12,2	026784
630 A- 3/4 x 7/8	295	11,9	12,9	026791
630 A- 25/32 x 13/16	295	12,2	12,5	026777
630 A- 13/16 x 7/8	315	12,5	13,2	026739
630 A- 7/8 x 15/16	315	12,9	13,5	026838
630 A- 15/16 x 1	330	13,5	14,1	026746
630 A- 1 x 1 1/8	350	14,1	15,6	026760
630 A- 1 1/16 x 1 1/8	350	14,4	15,0	026708
630 A- 1 1/16 x 1 1/4	365	14,8	16,4	026692

Double Box-End Wrenches Sets



cardboard packed

HAZET No.	EAN-No. 4000896+
8 parts	
contents:	
630-6 x 7	8 x 9
10 x 11	12 x 13
14 x 15	16 x 17
18 x 19	21 x 22
630/8	026654
9 parts	
contents:	
630-6 x 7	8 x 9
10 x 11	12 x 13
14 x 15	17 x 19
21 x 22	24 x 27
30 x 32	
630/9	026661
10 parts	
contents:	
630-6 x 7	8 x 9
10 x 11	12 x 13
14 x 15	16 x 17
18 x 19	21 x 22
24 x 27	30 x 32
630/10-1	026586
12 parts	
contents:	
630-6 x 7	8 x 9
10 x 11	12 x 13
14 x 15	16 x 17
18 x 19	20 x 22
21 x 23	24 x 26
25 x 28	27 x 32
630/12	026593

American sizes

HAZET No.	EAN-No. 4000896+
6 parts	
contents:	
630 A- 3/8 x 7/16	1/2 x 9/16
5/8 x 11/16	3/4 x 25/32
19/16 x 7/8	15/16 x 1
630 A/6	026852
8 parts	
contents:	
630 A- 1/4 x 5/16	3/8 x 7/16
1/2 x 9/16	5/8 x 11/16
3/4 x 25/32	19/16 x 7/8
15/16 x 1	1 1/16 x 1 1/4
630 A/8	026876
12 parts	
contents:	
630 A- 1/4 x 5/16	3/8 x 7/16
1/2 x 9/16	19/32 x 11/16
5/8 x 11/16	3/8 x 3/4
3/4 x 7/8	25/32 x 19/16
7/8 x 15/16	19/16 x 1
1 x 1 1/8	1 1/16 x 1 1/4
630 A/12	026845

TORX® Double Box-End Wrenches



- For outside TORX® screws
- Deep offset
- Chrome-Vanadium
- Surface chrome-plated, heads polished

HAZET No.	mm	EAN-No. 4000896+
630-E 4 x E 5	3,86 x 4,75	053513
630-E 6 x E 7	5,74 x 6,22	053520
630-E 8 x E 10	7,52 x 9,42	053537
630-E 11 x E 12	10,08 x 11,17	053544
630-E 14 x E 16	12,90 x 14,76	053551
630-E 18 x E 20	16,70 x 18,49	053568
630-E 22 x E 24	20,31 x 22,16	053575

TORX® Double Box-End Wrenches Set

7 parts

contents:
630-E 4 x E 5 E 6 x E 7 E 8 x E 10 E 11 x E 12
E 14 x E 16 E 18 x E 20 E 22 x E 24

HAZET No.	EAN-No. 4000896+
630-E/7	056385

Heavy Duty Box-End Wrenches

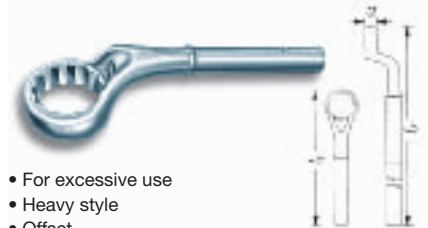

- For excessive use
 - Heavy style
 - Offset
 - Chrome-Vanadium
 - Surface chrome-plated
- tubular handles see 640-2430 to -6080

HAZET No.	l ₁ mm	l ₂ mm	a mm	EAN-No. 4000896+
640- 24	198,5	559	17,0	027194
640- 27	200,0	560	17,0	027217
640- 30	207,0	568	18,0	027224
640- 32	235,0	721	18,0	027231
640- 36	245,0	731	20,0	027255
640- 41	250,0	736	21,0	027262
640- 46	280,0	912	23,0	027279
640- 50	290,0	922	25,5	027309
640- 55	300,0	925	28,0	027316
640- 60	345,0	1039	30,5	027323
640- 65	355,0	1049	33,0	027347
640- 70	365,0	1059	35,5	027354
640- 75	375,0	1069	38,0	027361
640- 80	385,0	1075	40,5	027378
640- 85	385,0	1076	40,5	027385
640- 90	410,0	1100	45,0	027392
640- 95	410,0	1100	45,0	027408
640-100	412,0	1103	45,0	027187

Tubular Handles



- Steel tube
- For a.m. Heavy Duty Box-End Wrenches
- Surface chrome-plated

HAZET No.	l mm	EAN-No. 4000896+
for wrenches 24 up to 30 mm		
640-2430	460	027200
for wrenches 32 up to 41 mm		
640-3241	610	027248
for wrenches 46 up to 55 mm		
640-4655	760	027286
for wrenches 60 up to 100 mm		
640-6080	860	027330

Box-End Wrenches Striking Face Pattern



- For excessive impact stress
- Special steel
- DIN 7444

American sizes on request

Box-End Wrenches Striking Face Pattern

HAZET No.	l mm	a mm	b mm	EAN-No. 4000896+
642- 27	180	16	46	027743
642- 30	190	17	52	027750
642- 32	190	17	52	027767
642- 36	205	18	58	027774
642- 41	230	20	66	027781
642- 46	240	22	74	027798
642- 50	255	24	80	027804
642- 55	270	25	86	027811
642- 60	280	26	93	027828
642- 65	300	30	102	027835
642- 70	330	33	110	027842
642- 75	330	33	110	027859
642- 80	360	36	126	027866
642- 85	360	36	126	027873
642- 90	390	40	142	027880
642- 95	390	40	142	027897
642-100	420	45	155	027699

Flexible Head Wrenches



- For working in areas with restricted access
- Flexible 12-point socket on both sides
- Chrome-Vanadium
- Surface chrome-plated, polished heads

HAZET No.	l mm	d ₁ mm	d ₂ mm	EAN-No. 4000896+
645- 6 x 7	162,7	9,5	10,5	028283
645- 8 x 9	179,4	12,0	13,5	028290
645-10 x 11	198,5	14,5	16,0	028030
645-12 x 13	214,4	17,5	19,0	028061
645-14 x 15	232,0	20,0	21,5	028092
645-16 x 17	243,2	23,0	24,0	028122
645-17 x 19	259,1	24,0	27,0	028146
645-18 x 19	259,1	25,0	27,0	028160
645-21 x 22	277,0	29,0	30,0	028214

Flexible Head Wrenches Set

cardboard packed
7 parts

contents:
645-8 x 9 10 x 11 12 x 13 14 x 15
16 x 17 18 x 19 21 x 22

HAZET No.	EAN-No. 4000896+
645/7	028313

Tire Irons



- Double-T profile ensures high stability
- Chrome-Vanadium
- Surface chrome-plated
- For passenger cars and transporters
- 650-8 for motorcycles

HAZET No.	l mm	EAN-No. 4000896+
650- 8	199	028672
650-12	303	028627
650-16	396	028634
650-20	500	028641
650-24	598	028658

Tire Irons

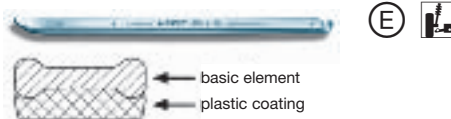

- For tire installation and removing
- For steel and aluminium rims
- With replaceable **plastic coating** fixed by screws
- Chrome-Vanadium
- Surface chrome-plated

HAZET No.	l mm	EAN-No. 4000896+
650 K-20	500	028696



- For commercial vehicles, agricultural and building machinery
- Heavy design
- Chrome-Vanadium

HAZET No.	l mm	EAN-No. 4000896+
652	600	028702



- Especially for tubeless tires
- Heavy design
- Chrome-Vanadium

HAZET No.	l mm	EAN-No. 4000896+
653	456	028719

Balance Weight Pliers



- For installing, removing and cutting of the **balance weights**
- Also for expanding and compressing the retaining springs
- Chrome-Vanadium
- Surface chrome-plated

HAZET No.	l mm	EAN-No. 4000896+
665	245	029204



- For installing, removing and cutting of the **balance weights**
- Also for expanding and compressing the retaining springs
- **With plastic head** at the hammer side
- Esp. for lacquered weights
- Chrome-Vanadium
- Surface chrome-plated

HAZET No.	l mm	EAN-No. 4000896+
665-1	245	029228



HAZET No.	l mm	EAN-No. 4000896+
665-01	-	029211

Valve Tool



- For installing and removing the tire valve cores
- For pushing in the valve pin when deflating the tire, e.g. on passenger cars, transporters and commercial vehicles

HAZET No.	EAN-No. 4000896+
666-1	087136

Valve Retracting Tool



- For pulling rubber-covered valves of different sizes into the rim holes of tubeless tires
- Easy application
- T-handle allows installing the valve without lifting it over the rim edge

HAZET No.	EAN-No. 4000896+
666-2	088461

Pliers for Wheel Nut Caps



- Enables the damage-free removal of wheel nut caps on aluminium rims e.g. on AUDI, VW and OPEL
- The pliers' jaw tips are especially shaped for the nut caps
- Special steel
- Surface bright chrome-plated, Handles with dip coating

HAZET No.	l mm	EAN-No. 4000896+
666-10	160	110575

Removing Tool for stick-on weights



- For removing stick-on weights and adhesives from the rims
- **For light alloy wheels**
- With sharp-edged groove, with screwed-on plastic wedge (for removal of adhesives from the disk wheel)
- Chrome-Vanadium
- Surface mirror galvanized
- DBP

HAZET No.	l mm	EAN-No. 4000896+
667	155	029235

Tool Set for Tire Pressure Control Systems



- For the appropriate installation of Beru and Schrader tire pressure sensors and the corresponding special tire valves
- Approx. 75% of the new cars until 2006 will be equipped with these sensors. The vehicles of the following manufacturers are already provided: BMW (7, Z8), MERCEDES-BENZ (CL, E, S, SL-classes), OPEL (Vectra), as well as various passenger cars of PEUGEOT, CITROËN, RENAULT
- Set with 6 parts in black plastic box with PUR foam insert

contents:

666-1
850 Lg-11 12
8502-T 20
866 U
6108-1 CT

HAZET No.	EAN-No. 4000896+
669-1	089208

Four-Way Rim Wrenches

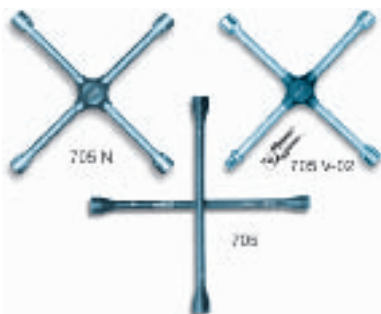

- For passenger cars, transporters and people carriers
- 705 V-02 additionally equipped with $12.5 = \frac{1}{2}$ " for sockets of the 900 series
- Special steel
- Surface chrome-plated,
- 705: surface powder coated, black
- DIN 3119, ISO 6788

HAZET No.	mm	EAN-No. 4000896+
705 N	17 x 19 x $1\frac{3}{16}$ x 21	029389
705	17 x 19 x $1\frac{3}{16}$ x 21	029358
705 V-02	17 x 19 x 22 x $1\frac{1}{2}$	029396



- For commercial vehicles and people carriers
- Special steel
- Surface powder coated, black
- DIN 3119, ISO 6788

HAZET No.	mm	EAN-No. 4000896+
710	19 x 22 x 24 x 27	029440

Four-Way Rim Wrenches

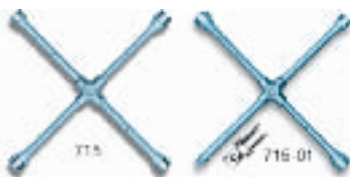

- For passenger cars, transporters, people carriers and agricultural machinery
- **High capacity**
- **Tested up to 500 Nm**
- Forged central piece
- 715-01 with $12.5 = \frac{1}{2}$ " for Sockets of the 900 series
- Chrome-Vanadium
- Surface chrome-plated, polished heads
- DIN 3119, ISO 6788

HAZET No.	mm	EAN-No. 4000896+
715	17 x 19 x $1\frac{3}{16}$ x 22	029457
715-01	17 x 19 x 22 x $1\frac{1}{2}$	029464

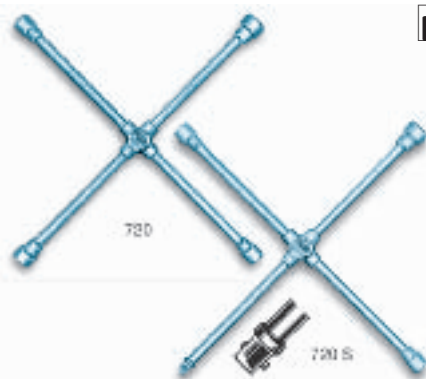

- For commercial vehicles, tractors, agricultural and building machinery
- **High capacity**
- **Tested up to 2000 Nm**
- Forged central piece
- 720 S with $20 = \frac{3}{4}$ " for Sockets of the 1000 series
- Chrome-Vanadium
- Surface chrome-plated, polished heads
- DIN 3119

HAZET No.	mm	EAN-No. 4000896+
720	27 x 30 x 32 x 36 ($1\frac{1}{16}$ x $1\frac{3}{16}$ x $1\frac{1}{4}$ x $1\frac{7}{16}$)	029501
720-30	24 x 27 x 30 x 32 ($1\frac{15}{16}$ x $1\frac{11}{16}$ x $1\frac{3}{16}$ x $1\frac{1}{4}$)	029518
720 S	24 x 27 x 32 x $2\frac{3}{4}$	029532

Flat Chisels



- Rectangular stock
- Chrome-Vanadium, air-hardened
- DIN 6453

HAZET No.	min. mm	l mm	EAN-No. 4000896+
730-1	15	100	029556
730-2	15	125	029563
730-3	18	150	029570
730-4	21	150	029587
730-5	21	175	029594
730-6	24	200	029600
730-7	25	250	029617
730-8	26	300	029624

Hand Guard

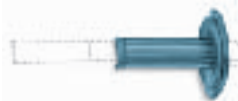

- For flat chisels 730-6, -7, -8
- Made of shock-resistant plastic

HAZET No.	EAN-No. 4000896+
730 HS	029631

Flat Chisels



- Octagonal stock
- Chrome-Vanadium, air-hardened

HAZET No.	min. mm	l mm	EAN-No. 4000896+
731-2	11	125	029648
731-5	15	150	029655

Cape Chisels



- Rectangular stock
- Chrome-Vanadium, air-hardened
- DIN 6451

HAZET No.	min. mm	l mm	EAN-No. 4000896+
740-2	5	125	029662
740-3	6	150	029679
740-5	7	175	029686
740-6	8	200	029693



- Octagonal stock
- Chrome-Vanadium, air-hardened

HAZET No.	min. mm	l mm	EAN-No. 4000896+
741-1	4	125	029709

Drift Punches



- Light design (B)
- Octagonal stock
- Chrome-Vanadium, air-hardened
- Surface mat black
- DIN 6458

HAZET No.	Ø mm	l mm	EAN-No. 4000896+
745-1	1	120	029716
745-2	2	120	029723
745-3	3	120	029730
745-4	4	120	029747

heavy design (D)

HAZET No.	Ø mm	l mm	EAN-No. 4000896+
745 a- 2	2	120	029778
745 a- 3	3	120	029785
745 a- 4	4	120	029792
745 a- 5	5	120	029808
745 a- 6	6	120	029815
745 a- 7	7	120	029822
745 a- 8	8	120	029839
745 a-10	10	150	029761

Center Punches



- Octagonal stock
- Chrome-Vanadium, air-hardened
- DIN 7250

HAZET No.	l mm	EAN-No. 4000896+
746-1	120	029846
746-2	120	029853

Auto-Impact Center Punches



- Impact force 3 – 30 kg
- Progressively adjustable
- Tough-hard punch tip
- The impact forces will be released by pressing down the upper part
- Special steel

HAZET No.	EAN-No. 4000896+
747-1	051434
Punch tip for 747-1	
747-02	051380

Drift Pins



- Octagonal stock
- Chrome-Vanadium, air-hardened
- DIN 6450, form C

+ = long style

HAZET No.	Ø max. mm	l mm	EAN-No. 4000896+
748 a- 2	2	115	029884
748 a- 3	3	125	029891
748 b- 2	2	150	029907
748 b- 3	3	150	029914
748 b- 4	4	150	029921
748 b- 5	5	150	029938
748 b- 6	6	150	029945
748 b- 8	8	150	029952
748 c- 6 +	6	180	029976
748 c- 8 +	8	200	029983
748 c-10 +	10	200	029969



Chrome-Vanadium, air-hardened

HAZET No.	Ø mm	l mm	EAN-No. 4000896+
• Especially for safety bolts on rear disk brakes MERCEDES-BENZ E-class 211			
• Ø 3 mm			
748 Lg b-3	10	175	100040
• Especially for safety bolts on disk brakes			
• Ø 4 mm			
748 Lg b-4	10	175	029990



- For the safety bolts of brake linings on floating caliper brakes, especially OPEL
- With guide pin
- Ø 3 or 5.8 mm
- Chrome-Vanadium
- Surface mat chrome-plated
- DIN 6450

HAZET No.	d ₁ mm	d ₂ mm	l mm	EAN-No. 4000896+
748 Lg b-6	3	5,8	175	030002

Chisels, Drift Punches, Center Punches

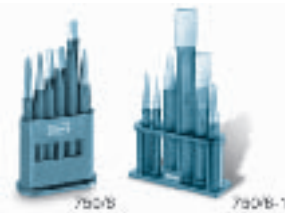

sets with 6 parts on plastic display stands

HAZET No.	EAN-No. 4000896+
contents:	
731-2 5 741-1 745 a-4 745-3 746-1	
750/6	030026
contents:	
730-3 6 740-3 745 a-4 745-2 746-2	
750/6-1	030033

Drift Pin Sets



sets with 6 parts on plastic display stands

HAZET No.	EAN-No. 4000896+
contents:	
748 a-2 3 748 b-4 5 748 c-6 8	
751/6	030088
contents:	
748 b-2 3 4 5 6 8	
751/6-1	030095

Special Body and Fender Grip Pliers

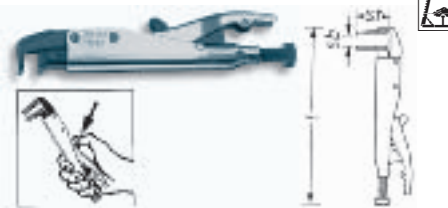

- Cramping to the fold at right angles
- Passenger cars: adjusting of doors, tailgates, engine hoods without removing the Pliers
- Especially suitable for curves due to the slim design
- Gripping power works in axial direction
- With quick-release lever
- For application on door entry widths, rear parts, wheel housings, problematical areas, etc.
- Jaws made of special steel
- Bright nickel-plated

HAZET No.	l mm	sb st b mm	EAN-No. 4000896+
752-1	195	18 - 18	030101



- For working on U-beams and weld seams in the fold
- For rear parts (adjustment), rear side panels, U-shaped body profiles, etc.

HAZET No.	l mm	sb st b mm	EAN-No. 4000896+
752-2	205	15-7-18	030125

Special Body and Fender Grip Pliers



- For spot welding with shielding gas between the jaws
- Also appropriate for U-beams
- Application on door sills, wheel arches, side panels, problematical areas, etc.

HAZET No.	l mm	sb st b mm	EAN-No. 4000896+
752-3	210	15-9-40	030149



- For working on rear and side parts, cramping bodywork profiles etc.
- Wide span

HAZET No.	l mm	sb st b mm	EAN-No. 4000896+
752-4	230	15-27-40	030156



- For spot welding within pipe grips
- Application on door entry widths, side parts, folded sheet metal, etc.

HAZET No.	l mm	sb st b mm	EAN-No. 4000896+
752-5	195	15-36-57	030163

Special Body and Fender Grip Pliers Set



set with 5 parts

contents:
752-1 2 3 4 5

HAZET No.	EAN-No. 4000896+
752/5	030170

Micro-Grip Pliers



- For areas with restricted space
- Only 92 mm long
- Ergonomic design, 120 g light
- Smooth rounded edges
- Straight motion of the mobile jaw
- One hand operation possible
- Brass screw for micrometer adjustment
- High-quality, heat treated aluminium alloy

HAZET No.	l mm	EAN-No. 4000896+
752-10	92	071920

Special Body and Fender Grip Pliers

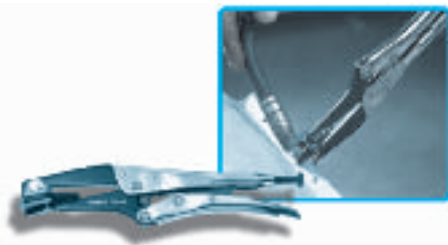

- Spot Welding Grip Pliers
- Especially for thin sheet metal
- With copper plate as retainer, avoiding melt-through of thin sheets
- Jaws made of special steel
- Surface bright nickel-plated

HAZET No.	l mm	sb mm	st b mm	EAN-No. 4000896+
752-15	240	15		055746

Wheel Housing Grip Pliers

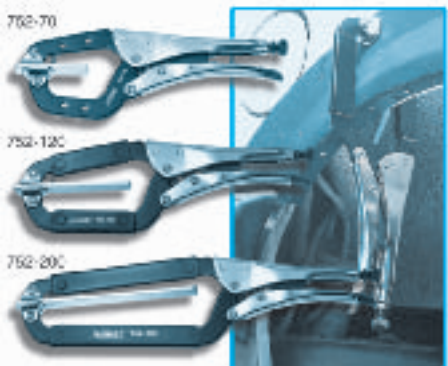

- With long flexible retainer – with spring –
- Adapts to the form of e.g. inside wheel cases
- Avoids slipping down of pliers
- With short flexible jaw – avoids damages

HAZET No.	l mm	EAN-No. 4000896+
752- 70	290	055715
752-120	350	055722
752-200	440	055739

Universal Grip Pliers

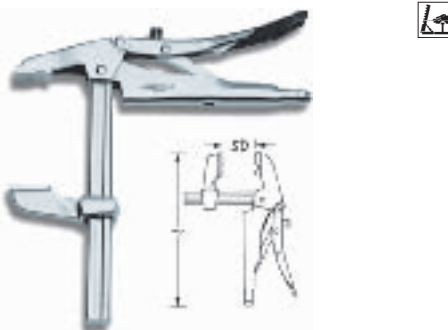

- For small round parts and bulky work pieces
- Parallel grip jaws – clamping function –
- One-sided prismatic groove
- Long guide pin
- Quick-release lever
- Jaws made of Chrome-Vanadium
- Surface nickel-plated

HAZET No.	l mm	sb mm	sb mm	EAN-No. 4000896+
753-1	260	100	5- 75	030194
753-2	260	200	5- 75	030231

Set of Top Jaws



(2 pairs)
for 753-1 and -2

HAZET No.	EAN-No. 4000896+
753-01	030187

Grip Pliers



- Straight jaws
- Quick-release lever
- Surface nickel-plated

HAZET No.	l mm	sb mm	sb mm	EAN-No. 4000896+
753-10	250	35	35	030200



- One jaw straight, one half-round, with one swivel jaw
- Surface nickel-plated

HAZET No.	l mm	sb mm	sb mm	EAN-No. 4000896+
753-10 S	250	43	16-43	030217

Parallel Grip Pliers



- Straight jaws
- Surface nickel-plated

HAZET No.	l mm	sb mm	sb mm	EAN-No. 4000896+
754-10	250	50	51	030248

Grip Pliers



- One jaw straight, one half-round
- Quick-release lever
- Surface nickel-plated

HAZET No.	l mm	sb mm	sb mm	EAN-No. 4000896+
755- 7	190	40	3,5-35	030279
755-10	240	45	6 -40	030262
755-12	300	50	0 -50	064335

Universal Grip Pliers



- Jaws half-round
- Quick-release lever
- Surface nickel-plated

HAZET No.	l mm	sb mm	sb mm	EAN-No. 4000896+
757- 5	142	25	0-25	062300
757- 7	178	20	8-30	030347
757-10	230	50	6-50	030293
757-12	300	30	10-65	030323

Grip Welding Clamps



- Especially for tubes
- Broad quick-release lever
- Surface nickel-plated

HAZET No.	l mm	sb mm	sb mm	EAN-No. 4000896+
758	280	85	10-85	030354



- Especially for getting over obstacles
- Quick-release lever
- Surface nickel-plated

HAZET No.	l mm	sb mm	sb mm	EAN-No. 4000896+
758-1	280	51	35-60	030361

Grip Pliers



- Especially for bulky objects
- Quick-release lever
- Surface nickel-plated

HAZET No.	l mm	sb mm	t ₁ mm	t ₂ mm	EAN-No. 4000896+
758-2	275	90	170	75	030378



- Especially great clamping depth
- Quick-release lever
- Surface nickel-plated

HAZET No.	l mm	sb mm	t ₁ mm	t ₂ mm	EAN-No. 4000896+
758-3	460	240	75-100	260	030385
758-4	600	320	75-100	400	030392

Universal Pliers



- Water pump pliers
- Box-joint
- Jaw and joint polished
- Surface lacquered red
- DIN ISO 8976

HAZET No.	l mm	sb mm	sb mm	EAN-No. 4000896+
759 N-2	240	30	6-35	030415

Universal Pliers



(E)

- Lay-on slip joint
- Surface chrome-plated
- DIN ISO 8976

HAZET No.	l mm	sb mm	sb mm	EAN-No. 4000896+
760-1	120	20	6-26	030422

Universal Pliers



(E)

- High capacity
- Fluted lay-on slip joint
- Relief-milled guide flutes
- Inductive hardened
- Chrome-Vanadium
- Surface chrome-plated, bright heads
- DIN ISO 8976

HAZET No.	l mm	sb mm	sb mm	EAN-No. 4000896+
760 N-1	180	30	45	030460
760 N-2	260	50	65	030484
760 N-3	310	65	80	030514
760 N-4	415	110	120	030538

Rim Wrenches



(E)

- For commercial vehicles
- Chrome-Vanadium
- Surface chrome-plated, bright heads

HAZET No.	mm	mm	l mm	EAN-No. 4000896+
769- 1	24 x 27	15/16 x 1.1/16	402	030743
769- 2	28 x 33	- x 1.5/16	402	030750
769-30	30 x 32	3/16 x 1.1/4	402	030767
769 S-3	32 x 38	1/2 x 1.1/2	407	030781

Handle Bar



- Chrome-plated

HAZET No.	l mm	mm	EAN-No. 4000896+
769-4	630	19 mm ϕ	030774

Rim Wrenches



(E)

- Telescoping
- Special steel
- Surface chrome-plated

HAZET No.	l mm	mm	EAN-No. 4000896+
771-17	364-520	17	030798
771-19	380-535	19 3/4	030828
771-21	380-535	21	030859

Rim Wrenches

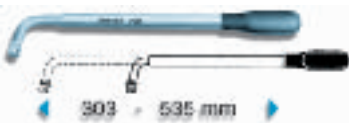

- Telescopic part solid drop forged
- With \blacksquare square drive 12.5 = 1/2"
- For Sockets of series HAZET 900
- Special steel
- Surface chrome-plated

HAZET No.	l mm	mm	EAN-No. 4000896+
772	303-535	12.5 1/2	030897

Pulling Devices



- For pulling off ball bearings, roller bearings and inner raceways
- To be used with HAZET Separators 775-60 75 115
- When working with the separators the puller claws are screwed into the threaded holes of the split flanges
- Special steel
- Surface galvanized/burnished

HAZET No.	sb mm	EAN-No. 4000896+
775-12	41-117	030941
775-16	56-146	030958
775-21	56-208	030965

Extensions



- Per pair
- Surface burnished

HAZET No.	l mm	EAN-No. 4000896+
for 775-12 and -16		
775-012	100	030903
for 775-21		
775-021	100	030910

Separators



- The split flanges move inwards when operating the nuts on the side bolts
- Special steel
- Surface galvanized/burnished

HAZET No.	a mm	EAN-No. 4000896+
775-60	5- 60	030972
775-75	12- 75	030989
775-115	22-115	030934

HAZET displays and the new BLUE LINE tool system – best possible presentation of ingenious tools!



Pitman Arm Pullers

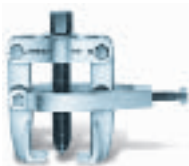

- For ball bearings, toothed wheels, pinions, **pitman arms** and similar
- The clamp clip is used for pressing the puller jaws on the parts to be extracted
- Special steel
- Surface galvanized

HAZET No.	sb max. mm	st mm	EAN-No. 4000896+
776-65	80	90	031009
776-80	100	100	031016
776-145	150	140	030996

Universal Ball Joint Pullers



- For removing the ball joint pivots of pitman arms, steering tie rods, steering knuckles, stabilizers, etc.
- Span of jaw 18-22 mm
- Great clamping range due to continuous vertical adjustment and turn-over of the lower part
- Special steel
- Surface galvanized

HAZET No.	sb max. mm	a mm	EAN-No. 4000896+
779	55	22	031023



- For removing the **ball joint pivots** of steering tie rods, stabilizers, etc.
- Span of jaw 20-22 mm
- Clamping range in 2 stages
stage 1: to 30 mm
stage 2: to 50 mm
- On FORD, BMW, VOLVO, TOYOTA, OPEL, VW-AUDI, RENAULT, NISSAN, FIAT and MERCEDES-BENZ passenger cars
- Special steel
- Surface galvanized

HAZET No.	sb max. mm	a mm	EAN-No. 4000896+
779-1	50	20-22	031030

Ball Joint Pullers



- For removing the **ball joint pivots** of pitman arms, steering tie rods, stabilizers, etc.
- Solid construction and deep holding slot enable easy and universal use
- Special steel
- Surface galvanized

HAZET No.	sb max. mm	a mm	EAN-No. 4000896+
-----------	------------	------	------------------

e.g. for commercial vehicles, light construction

779-2	70	34	072552
-------	----	----	--------

e.g. for heavy commercial vehicles

779-3	85	40	072569
-------	----	----	--------

Ball Joint Pullers



- For removing the **ball joint pivots on vehicles with aluminium chassis** e.g. AUDI A6 and A8
- **Mechanical**
- Special steel
- Surface galvanized

HAZET No.	sb max. mm	a mm	EAN-No. 4000896+
779 A-2	65	30	082056



- For removing the **ball joint pivots** and for the safe removing of ball joints
- Supported by hydraulic system
- Special steel
- Surface galvanized

HAZET No.	sb max. mm	a mm	EAN-No. 4000896+
-----------	------------	------	------------------

- For passenger cars, vans and commercial vehicles
- Capacity: 10 tons

779 H-2	70	30-34	082049
---------	----	-------	--------

- For commercial vehicles, busses and building machinery
- Capacity: 15 tons

779 H-3	85	36-40	082032
---------	----	-------	--------

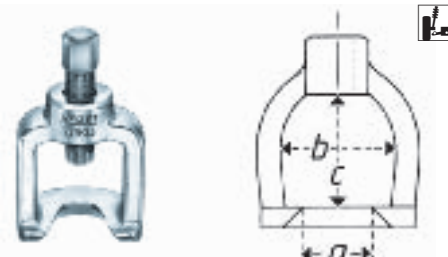

- For removing the ball joint pivots of steering tie rods, stabilizers, etc.
- Special steel
- Surface galvanized
- a = span of jaw

HAZET No.	b mm	a mm	c mm	EAN-No. 4000896+
-----------	------	------	------	------------------

779-18	36,5	18	38	031047
--------	------	----	----	--------

779-23	45,0	23	48	031054
--------	------	----	----	--------

779-29	61,5	29	63	031061
--------	------	----	----	--------

779-39	62,0	39	78	031078
--------	------	----	----	--------

e.g. for commercial vehicles

779-55	77,0	55	100	057078
--------	------	----	-----	--------

Universal Hub Puller



- Movable and replaceable puller claws
- With 5 puller claws

Universal Hub Puller

- Special steel
- Surface galvanized

HAZET No.	sb max. mm	EAN-No. 4000896+
781-5	115-225	031108

Gear Pullers



- For pulling off toothed wheels and ball bearings
- Puller claws usable on both sides with one narrow side for areas with restricted access
- With 2 puller claws
- Special steel
- Surface galvanized

HAZET No.	sb max. mm	st mm	EAN-No. 4000896+
784-15	150	85	031122
784-20	220	130	031139

Gear Pullers



- For pulling off toothed wheels and ball bearings
- Puller claws usable on both sides with one narrow side for areas with restricted access
- With 3 puller claws
- Special steel
- Surface galvanized

HAZET No.	sb max. mm	st max. mm	EAN-No. 4000896+
785-15	150	85	031146
785-20	220	130	031153

Universal Two-Armed Gear Pullers



- Reversible puller claws enable application as inside and outside puller
- Special steel
- Surface galvanized

HAZET No.	sb max. mm	st mm	EAN-No. 4000896+
787 N-08	80	106	031160
787 N-12	120	106	031184
787 N-16	160	158	031191
787 N-20	200	158	031214
787 N-25	250	208	031221
787 N-35	350	208	031245
787 N-52	520	208	031252

Puller Claws



- Per pair
- For 787 N-08 to -52
- * = extra long style

HAZET No.		s† mm	EAN-No. 4000896+
787 N-0812	787 N-08/12	106	031177
787 N-1620	16/20	158	031207
787 N-2552	25/35/52	208	031238
787 N Lg-0812 *	08/12	205	031269
787 N Lg-1620 *	16/20	300	031276
787 N Lg-2552 *	25/35/52	305	031283
787 N Lg-2552/4 *	25/35/52	406	031290
787 N Lg-2552/5 *	25/35/52	504	031306

Internal Extractors

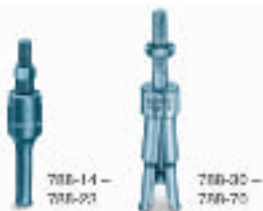

- For extracting **ball bearings, outer rings and bushings**
- Special steel
- to be used with Counter Stays
- HAZET 788-1437 -4670
- 788-14 up to 23: black
- 788-30 up to 70: galvanized

HAZET No.	∅ mm	EAN-No. 4000896+
788-14	12-16	031313
788-18	14-19	031337
788-23	18-23	031344
788-30	20-30	031351
788-37	28-40	031368
788-46	36-46	031375
788-56	45-58	031399
788-70	56-70	031405

Counter Stays



- For Internal Extractors HAZET 788-14 to -70
- Special steel
- Surface galvanized

HAZET No.		EAN-No. 4000896+
788-1437	788-14 --37	031320
788-4670	788-23 --70	031382

Pulley Extractor



- For **pulleys on passenger cars** up to 132 mm ∅
- Esp. appropriate for areas with restricted access
- With extraction hook for effective depth up to 68 mm, resp. with extension up to 88 mm
- 1 additional beam for pulleys with holes 132 – 195 mm ∅
- Special steel
- Surface galvanized

HAZET No.	EAN-No. 4000896+
789-1	080427

Piston Ring Pliers



- For installing and removing piston rings
- Special steel
- Surface bright nickel-plated

HAZET No.	∅ mm	l mm	EAN-No. 4000896+
790-1	50-100	220	031412
790-1 a	65-110	240	031429
790-2	110-150	280	031443



- With prism holder for safe grip of various piston ring types
- Special steel
- Surface nickel-plated, burnished prism holder

HAZET No.	∅ mm	l mm	EAN-No. 4000896+
790-3	60-120	220	031450

Valve Seal Ring Pliers



- For removing valve stem seals on **2-valve engines**
- On VW-AUDI, FORD, OPEL, NISSAN, etc.

Valve Seal Ring Pliers

- Serrated and hardened jaws
 - Surface nickel-plated, jaws burnished
- | HAZET No. | l mm | EAN-No. 4000896+ |
|-----------|------|------------------|
| 791-5 | 250 | 031467 |

Valve Stem Seal Ring Pliers



- For easy and reliable removing of deeply located valve stem seals due to the extra long jaws
- For **multi-valve engines** e.g. on OPEL, VW and FORD
- Serrated and dip-coated jaws
- Jaws hardened
- Straight
- Surface nickel-plated

HAZET No.	l mm	EAN-No. 4000896+
791-8	270	061068

Valve Spring Compressors

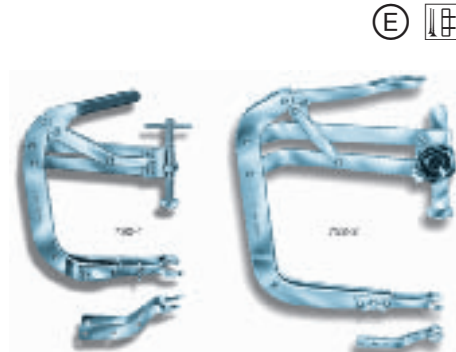

- With 1 pair of straight and bent jaws each,
 - 792-1 with straight jaws sb 75-225
 - with bent jaws sb 45-195
 - 792-2 with straight jaws sb 120-280
 - with bent jaws sb 90-250
- Surface nickel-plated

HAZET No.	l mm	EAN-No. 4000896+
792-1	290	031481
792-2	380	031511

Piston Ring Compressors



- With square key for tensioning
- May be locked continuously
- High-strength spring band steel

HAZET No.	∅ mm	h mm	EAN-No. 4000896+
794-01	40- 75	50	031597
794-1	60-125	80	031610
794-2	90-175	80	031641
794-3	90-175	165	031665



Piston Ring Compressor



(E)

- For compression of piston rings on water and air-cooled engines
- **Tightening strap (width 32 mm), can easily be unlatched**
- Surface chrome-plated

HAZET No.	∅ mm	l mm	EAN-No. 4000896+
794 U-3	70 - 100	302- 332	031672

Valve Refacers



with suction cup

HAZET No.	∅ mm	EAN-No. 4000896+
795-1	20	031771
795-2	25	031788
795-3	30	031795
795-4	37	031801

Brake Spring Pliers



- For installing and removing the brake shoe recuperating spring on **riveted brake linings**
- Surface chrome-plated

HAZET No.	l mm	EAN-No. 4000896+
796	215	031818



- For **glued and riveted brake linings**
- With movable claw
- Surface chrome-plated

HAZET No.	l mm	EAN-No. 4000896+
797	317	031825

Hose Clamp Pliers



(E)

- For simple hose clamps e.g. on washing machines
- Movable jaws
- Surface chrome-plated

HAZET No.	sb mm	l mm	EAN-No. 4000896+
798	40	206	031832

Hose Clamp Pliers



(E)

- For simple hose clamps
- With locking device
- Movable jaws
- Surface chrome-plated

HAZET No.	sb mm	l mm	EAN-No. 4000896+
798-1	45	285	031900

Hose Clamp Pliers



- For clamping multi-use **CLIC-type hose clamps** on fuel lines, e.g. on VW-AUDI, OPEL, PEUGEOT and ALFA ROMEO
- Turning pliers by 180° enables easy loosening and tightening
- With fixed jaws, bent 90°

HAZET No.	sb mm	l mm	EAN-No. 4000896+
798-2	20	175	051397



(N) (E)

- For clamping multi-use CLIC-type hose clamps that are used e.g. on fuel lines Application on e.g. AUDI, VW, OPEL, PEUGEOT, SMART and MERCEDES-BENZ
- Loosening and tightening by turning the pliers by 180°
- Movable jaws—for use in areas with restricted access
- Chrome-Vanadium
- Surface nickel-plated

HAZET No.	sb mm	l mm	EAN-No. 4000896+
798-3	35	206	102433

Hose Clamp Pliers



(E)

- For spring band hose clamps
- Movable jaws

HAZET No.	sb mm	l mm	EAN-No. 4000896+
798-4	35	205	031948

Hose Clamp Pliers



(E)

- For spring band hose clamps e.g. on VW-AUDI and OPEL
- Movable jaws

HAZET No.	sb mm	l mm	EAN-No. 4000896+
798-5	6-12	210	031955



(E)

- For spring band hose clamps **12 and 15 mm wide**, 13–22 mm ∅
- Movable jaws

HAZET No.	sb mm	l mm	EAN-No. 4000896+
798-6	40	235	031962

Hose Clamp Tension Device

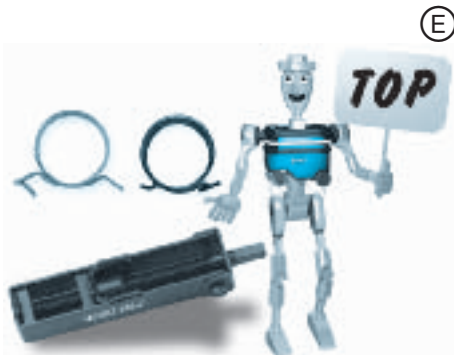

(E)

- For self-gripping **spring band hose clamps**
- Enables working in areas with restricted access
- Easy working in conjunction with Reversible Ratchet 863 P and 6-Point Socket 850-6
- 6-point drive ≤ 6 mm
- Surface galvanized

HAZET No.	sb mm	EAN-No. 4000896+
798-7	8-52	083206

Hose Clamp Pliers



- For self-gripping spring band hose clamps
- Self-adjusting joint allows easy working even on large hose clamps with large diameter
- With locking device
- Handles with plastic coating

HAZET No.	sb mm	l mm	EAN-No. 4000896+
798-8	45	290	076697



- Especially for **12 and 15 mm** self-gripping spring band hose clamps
- **Bent 110°**, may be therefore used in areas with restricted access
- With locking device

HAZET No.	sb mm	l mm	EAN-No. 4000896+
798-9	60	250	072163

Hose Clamp Pliers



(E)

- For spring band hose clamps
- Adjustable opening width
- Fixed jaws
- With locking device
- Esp. on VW-AUDI

HAZET No.	sb mm	l mm	EAN-No. 4000896+
798-10	90	320	031917



(E)

- For spring band hose clamps
- Especially for **12 mm** and **15 mm** spring band hose clamps e.g. on OPEL, VW, FORD, RENAULT, FIAT, PEUGEOT, CITROËN, PORSCHE, ALFA ROMEO, MERCEDES-BENZ, Smart
- With locking device
- Adjustable opening width
- Handles plastic coated

HAZET No.	sb mm	l mm	EAN-No. 4000896+
798-12	80	320	031931



(N)

- For the operation of spring band hose clamps whose three ends are located on tubes e.g. on fuel lines and tank ventilation lines on VW, AUDI, SEAT, SKODA
- Chrome-Vanadium
- Surface nickel-plated

HAZET No.	sb mm	l mm	EAN-No. 4000896+
798-14	8-18	177	109128



(E)

- For the operation of self-gripping spring band hose clamps
- **Bowden cable** (610 mm) enables application in areas with restricted access where the application of usual Hose Clamp Pliers is not possible
- With **toothed fixing device**
- Application on cooling and heating circuits
- Handles with plastic coating for better gripping comfort

HAZET No.	sb mm	l mm	EAN-No. 4000896+
798-15 A	8-52	875	097258

Bowden cable for 798-15 A
complete with fixing kit, 2 x nuts M 4

798-0151 A 097753

Bowden cable for 798-15 A

798-0152 A 097760

Sliding guide device for 798-15 A

798-0153 A 097784

Door-Spring Pliers



(K)



- For installing and removing the stop spring of the window crank
- Surface chrome-plated, jaws burnished

HAZET No.	sb mm	l mm	EAN-No. 4000896+
799	8-45	210	031986

Lever for Removing Door Panels



(K)

- For removing **fixing plugs** on door panels
- With protective coating
- Jaw opening 28 mm
- Special steel

HAZET No.	l mm	EAN-No. 4000896+
799-3	268	031993

Pliers for Dismantling Door Panels



(K)

- For removing the fixing bolts on **door panels**, mouldings and bumper rubber strips
- Coated for the protection of vehicle lacquer
- Special steel

HAZET No.	l mm	EAN-No. 4000896+
799-4	230	032013

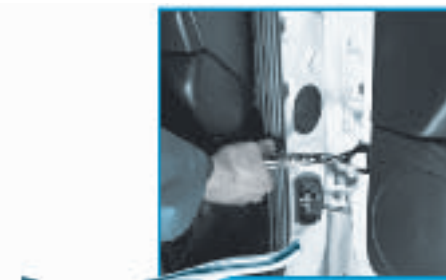

- For removing the fixing bolts **door panels**, mouldings and bumper rubber strips
- Coated for the protection of vehicle lacquer
- Also for VW Sharan, FORD Galaxy and SEAT Alhambra
- Special steel

HAZET No.	l mm	EAN-No. 4000896+
799-5	285	052042

Levers for Removing Door Panels



(N)

- For removing the fixing plugs on door panels – VW Sharan since 1996, Touareg since 2003, Touran since 2004, Phaeton since 2003 – SEAT Alhambra since 1996 – FORD Galaxy since 1995
- Lever provides an optimal power transmission
- Special steel with protective coating
- Ergonomic plastic handle

HAZET No.	l mm	EAN-No. 4000896+
799-6	260	110346



These tools make life easier



HAZET in the internet:
www.hazet.com

HAZET-Screwdrivers – Perfect tools for perfect results

- ✓ **Blades made of high-quality special steel**
- ✓ **Ergonomic handles to avoid bruises on the hands**
- ✓ **Always the right profile:**
- ✓ **Blades with hex bolster for higher torque values**

Please Note...

... our extensive product range of Screwdriver Bits from page 102 on.

Screwdrivers



- With handles made of Durethan®
- According to Swiss standard VSM 35601
- Blades offset, parallel faces
- Chrome-Vanadium
- Blades mat chrome-plated, Tips burnished
- Protected by design patent

HAZET No.	$\frac{1}{4}$ mm	$\frac{1}{2}$ mm	l_1 mm	EAN-No. 4000896+
800-00	0,3	2,0	70	032037
800-0	0,4	2,5	80	032020
800-1	0,5	3,5	90	032044
800-2	0,6	4,0	100	032051
800-3	0,8	5,5	120	032068
800-4	1,0	6,5	140	032075
800-5	1,2	8,0	160	032082
800-6	1,6	10,0	180	032099



- For Phillips-Recess screws

HAZET No.	l_1 mm	EAN-No. 4000896+
800-PH 0	60	032136
800-PH 1	80	032143
800-PH 2	100	032150



- For POZIDRIV® screws PZ

HAZET No.	l_1 mm	EAN-No. 4000896+
800-PZ 0	60	032167
800-PZ 1	80	032174
800-PZ 2	100	032181

Screwdriver Sets



Screwdriver Sets

* = in HAZET plastic drawer insert

HAZET No.	EAN-No. 4000896+
6 parts contents: 800-1 2 3 4 5 6	
800/6 *	032198
8 parts contents: 800-1 2 3 5 800-PH 1 PH 2 PZ 1 PZ 2	
800/8	032211
8 parts contents: 800-1 2 3 4 5 800-PH 0 PH 1 PH 2	
800/8-1	032228

ULTRA Screwdrivers

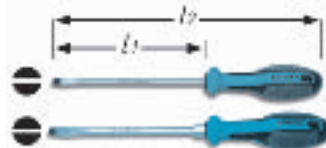

The new generation of ULTRA screwdrivers

- 4-component screwdrivers
 - Designer handle according to the latest developments in research
 - With hole to place an extra lever
 - Shock-resistant plastic material – “ULTRA”-resistant to gasoline, acid, Skydrol, brake fluid, etc.
 - Soft plastic material – with slide-off protection for axial pressure
 - With spinning area
 - Non-slipping even with greasy hands due to **microfibre coating**
 - High-quality special steel
 - Surface chrome-plated, tips burnished
- * = With **hex bolster** for wrenches – allows application of higher torque values

HAZET No.	l_1 mm	l_2 mm	$\frac{1}{4}$ mm	$\frac{1}{2}$ mm	EAN-No. 4000896+
• For slotted screws					
• DIN 5265 form A					
801-30	80	173	3,0	0,5	079896
801-40	100	209	4,0	0,8	079902
801-55	125	234	5,5	1,0	079919
801 S-55 *	100	196	5,5	1,0	089086
801-65	150	273	6,5	1,2	079926
801 S-65 *	125	235	6,5	1,2	089093
• Square blade with hex bolster					
• DIN 5265 C-series, ISO 2380-2					
801- 80 *	150	282	8,0	1,2	079933
801-100 *	175	307	10,0	1,6	079940
801-120 *	200	332	12,0	2,0	079957

ULTRA Screwdrivers

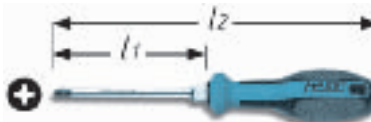

- For Phillips-Recess screws
- DIN ISO 8764-2, ISO 8764-2
- size PH 3: blade with hex bolster

HAZET No.	l_1 mm	l_2 mm	\emptyset mm	EAN-No. 4000896+
801-PH 0	60	153	–	079995
801-PH 1	80	189	–	080007
801-PH 2	100	223	–	080014
801-PH 3	150	282	13	080021

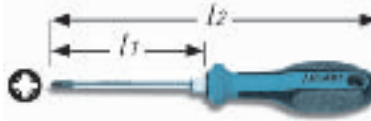

- For POZIDRIV® screws PZ
- size PZ 3: blade with hex bolster

HAZET No.	l_1 mm	l_2 mm	\emptyset mm	EAN-No. 4000896+
801-PZ 0	60	153	–	080052
801-PZ 1	80	189	–	080069
801-PZ 2	100	223	–	080076
801-PZ 3	150	282	13	080083

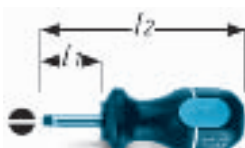

- For slotted screws
- Short style
- 2-component handle

HAZET No.	l_1 mm	l_2 mm	$\frac{1}{4}$ mm	$\frac{1}{2}$ mm	EAN-No. 4000896+
801 K-35	25	89	3,5	0,6	079964
801 K-55	25	89	5,5	1,0	079971
801 K-80	25	89	8,0	1,2	079988

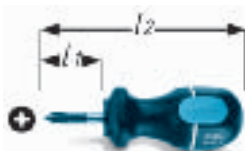

- For Phillips-Recess screws
- Short style
- 2-compound handle

HAZET No.	l_1 mm	l_2 mm	EAN-No. 4000896+
801 K-PH 1	25	89	080038
801 K-PH 2	25	89	080045

ULTRA Screwdrivers

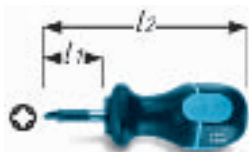

- For POZIDRIV® screws
- Short style
- 2-component handle

HAZET No.	l ₁ mm	l ₂ mm	EAN-No. 4000896+
801 K-PZ 1	25	89	080090
801 K-PZ 2	25	89	080106

Ultra Screwdrivers TORX®

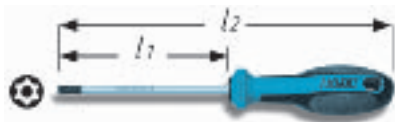

- For inside tamper TORX® screws (inside TORX® screws with pin)
- With bore hole on the face

HAZET No.	l ₁ mm	l ₂ mm	mm	EAN-No. 4000896+
801-T 8 H	60	156	2,31	087457
801-T 9 H	60	156	2,50	087464
801-T 10 H	80	176	2,74	080113
801-T 15 H	80	176	3,27	080120
801-T 20 H	100	210	3,86	080137
801-T 25 H	100	210	4,43	080144
801-T 27 H	115	225	4,99	080151
801-T 30 H	115	225	5,52	080168
801-T 40 H	115	235	6,65	080175
801-T 45 H	130	244	7,82	080182

ULTRA Screwdriver Sets



* = in HAZET plastic drawer insert

HAZET No.	EAN-No. 4000896+
6 parts	
contents:	
801-40 55 65 80	
801-PH 1 PH 2	
801/6 *	080434
10 parts	
contents:	
801-30 40 55 65 80 100	
801-PH 1 PH 2	
801 K-55 801 K-PH 2	
801/10	080298
5 parts	
contents:	
801-T 10 H T 15 H T 20 H T 25 H T 30 H	
801 T H/5 *	080243
7 parts	
contents:	
801-T 8 H T 9 H T 10 H T 15 H T 20 H T 25 H T 30 H	
801 T H/7 *	087471

Screwdrivers with Impact Cap



- Multicomponent handle provides optimal surfaces and a very good grip
- Impact cap made of tempered steel
- Blades with hexbolster for use with a wrench
- DIN 5265 form D, edges according to DIN 5264
- Chrome-Vanadium
- Blades chrome-plated, tips burnished

HAZET No.	l ₁ mm	l ₂ mm	mm	mm	EAN-No. 4000896+
801 U-45	90	199	4,5	0,7	109395
801 U-55	100	209	5,5	0,8	109401
801 U-70	125	248	7,0	1,0	109418
801 U-PH 1	90	194	-	-	109692
801 U-PH 2	100	223	-	-	109708
5 parts, cardboard packed					
801 U/5	-	-	-	-	109388

trinamic® Screwdrivers

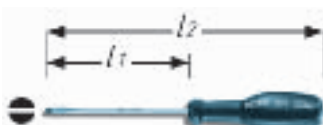

- With trinamic® handles
- Ergonomic design and high capacity
- High power transmission
- Chrome-Vanadium
- Blades chrome-plated, tips burnished

* = Blade with hex bolster allows application of high torque values

HAZET No.	l ₁ mm	l ₂ mm	mm	mm	EAN-No. 4000896+
• For slotted screws					
• DIN 5265, C-series					
803-20	63	126,5	2,0	0,4	077434
803-25	75	138,5	2,5	0,4	077441
803-30	80	151,5	3,0	0,5	077458
803-35	100	180,0	3,5	0,6	077465
803-40	100	189,5	4,0	0,8	077472
803-55	125	226,0	5,5	1,0	077489
803 S-55 *	125	218,0	5,5	1,0	089109
803-65	150	251,0	6,5	1,2	077496
803 S-65 *	150	260,0	6,5	1,2	089116
803- 80 *	150	268,5	8,0	1,2	077502
803-100 *	175	303,0	10,0	1,6	077519
803-120 *	200	328,0	12,0	2,0	077526
803-140 *	250	378,0	14,0	2,5	077533

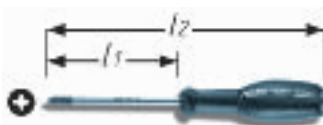

- For Phillips-Recess screws
- From size PH 3 on, blade with hex bolster
- DIN ISO 8764-2, ISO 8764-2

HAZET No.	l ₁ mm	l ₂ mm	mm	EAN-No. 4000896+
803-PH 0	60	138,0	-	077557
803-PH 1	80	168,0	-	077564
803-PH 2	100	200,0	-	077571
803-PH 3	150	265,5	13	077588
803-PH 4	200	325,0	16	077595

trinamic® Screwdrivers

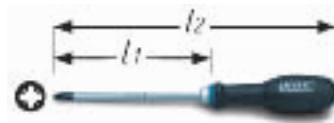

- For POZIDRIV® screws
- Marking ring blue
- From size PZ 3 on, blade with hex bolster

HAZET No.	l ₁ mm	l ₂ mm	mm	EAN-No. 4000896+
803-PZ 0	53,5	137,5	-	077625
803-PZ 1	73,0	166,5	-	077632
803-PZ 2	94,5	199,5	-	077649
803-PZ 3	142,0	265,0	13	077656
803-PZ 4	192,0	324,0	16	077663

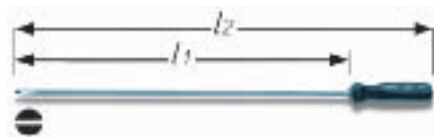

- For deeply located slotted screws
- Extra-long style

HAZET No.	l ₁ mm	l ₂ mm	mm	mm	EAN-No. 4000896+
803 Lg-55	410	520,5	5,5	1,0	077540

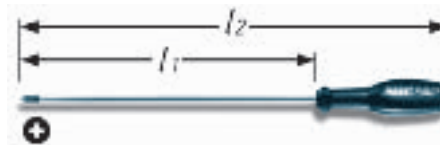

- For deeply located Phillips-Recess screws
- Extra-long style

HAZET No.	l ₁ mm	l ₂ mm	EAN-No. 4000896+
803 Lg-PH 1	250	340	077601
803 Lg-PH 2	250	351	077618

TORX® trinamic® Screwdrivers

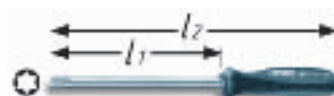

- For inside TORX® screws

HAZET No.	l ₁ mm	l ₂ mm	mm	EAN-No. 4000896+
803-T 6	48	112	1,67	077670
803-T 7	48	112	1,99	077687
803-T 8	55	127	2,31	077694
803-T 9	55	127	2,50	077700
803-T 10	70	150	2,74	077717
803-T 15	70	150	3,27	077724
803-T 20	84	175	3,86	077731
803-T 25	84	175	4,43	077748
803-T 27	99	200	4,99	077755
803-T 30	99	200	5,52	077762
803-T 40	99	217	6,65	086214
803-T 45	112	230	7,82	086221

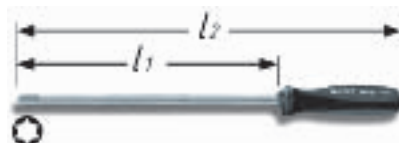

- For inside TORX® screws
- Long, slim style
- Application e.g. at the dashboard, car body, engine compartment as well as in industry

HAZET No.	l ₁ mm	l ₂ mm	mm	EAN-No. 4000896+
803 Lg-T 15	250	330	3,27	087785
803 Lg-T 20	250	343	3,86	087792
803 Lg-T 25	250	345	4,43	087808
803 Lg-T 30	250	360	5,52	087815

Screwdrivers for Electricians

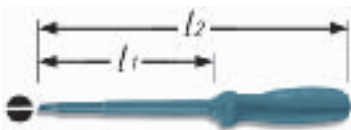

- For working on live parts, tension range to AC 1000 V and DC 1500 V
- All-insulated, red, according to standard DIN EN 60900 / IEC 900
- **For slotted screws**
- Functional dimensions according to DIN 7437, edges according to DIN 5264, form A
- Wedge-shaped
- Tips burnished

HAZET No.	l_1 mm	l_2 mm	$\frac{1}{4}$ mm	$\frac{3}{8}$ mm	EAN-No. 4000896+
803 VDE-25	75	155	2,5	0,4	079544
803 VDE-30	100	180	3,0	0,5	077786
803 VDE-35	100	190	3,5	0,6	077793
803 VDE-40	100	190	4,0	0,8	077809
803 VDE-55	125	225	5,5	1,0	077816
803 VDE-65	150	250	6,5	1,2	077823
parallel faces					
803 VDE-80	175	285	8,0	1,2	077830

Screwdrivers for Electricians

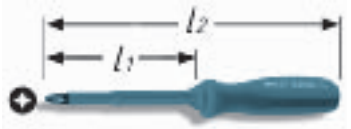

- **For Phillips-Recess screws**
- All-insulated, red, according to standard DIN EN 60900 / IEC 900
- Functional dimensions according to DIN 7438
- Tips burnished

HAZET No.	l_1 mm	l_2 mm	EAN-No. 4000896+
803 VDE-PH 0	60	140	077847
803 VDE-PH 1	80	170	077854
803 VDE-PH 2	100	200	077878
803 VDE-PH 3	150	260	077861

Screwdriver Sets



in HAZET plastic drawer insert (except: 803/6-2, 803 T/5, 803 T/7, 803 Lg-T/4)

HAZET No.	EAN-No. 4000896+
6 parts	
contents:	
803-40 55 65 80	
803-PH 1 PH 2	
803/6	080373

Screwdriver Sets

HAZET No.	EAN-No. 4000896+
-----------	------------------

6 parts	
contents:	
803-40 55 65 80 803-PZ 1 PZ 2	
803/6-1	080380

6 parts	
contents:	
803-25 30 35 40 55 65	
803/6-2	084777

10 parts	
contents:	
803-25 30 35 40 65 80	
803-PH 1 PH 2	
801 K-55 801 K-PH 2	
803/10	080236

13 parts	
contents:	
801 K-55 801 K-PH 2	
803-25 30 35 40 65 80	
803-PZ 1 PZ 2	
803-PH 1 PH 2 PH 3	
803/13	098514

for inside TORX® screws,	
5 parts	
contents:	
803-T 10 T 15 T 20 T 25 T 30	
803 T/5	080410

7 parts	
contents:	
803-T 8 T 9 T 10 T 15 T 20 T 25 T 30	
803 T/7	087334

Long style, for inside TORX® screws	
4 parts	
contents:	
803 Lg-T 15 T 20 T 25 T 30	
803 Lg-T/4	098798

Screwdriver Set for Electricians,	
6 parts	
contents:	
803 VDE-25 40 55 65	
803 VDE-PH 1 PH 2	
803 VDE/6	080229

Clip Screwdriver



- The versatile Screwdriver for everyday-use – always ready to hand
- With fibre reinforced scraper for damage-free removing of stickers etc.
- Clip holds Screwdriver tight in every pocket, e.g. breast or sleeve pocket
- Rotating clip improves handling
- Blade chrome-plated
- **For slotted screws**
- DBG M – German registered utility model

HAZET No.	l_1 mm	l_2 mm	$\frac{1}{4}$ mm	$\frac{3}{8}$ mm	EAN-No. 4000896+
805 C-25	30	130	2,5	0,4	089123

Electronic Screwdrivers

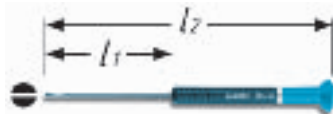

- For smallest screws
- With revolving-head
- Best grip due to recessed handle
- Chrome-Vanadium
- Blades burnished
- **For slotted screws**
- Marking ring grey

HAZET No.	l_1 mm	l_2 mm	$\frac{1}{4}$ mm	$\frac{3}{8}$ mm	EAN-No. 4000896+
805-015	40	140	1,5	0,3	032587
805-02	60	160	2,0	0,4	032594
805-025	75	175	2,5	0,4	032600
805-03	75	175	3,0	0,5	032617

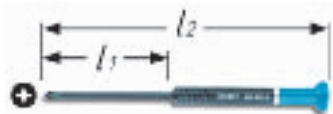

- **For Phillips-Recess screws**
- Marking ring yellow

HAZET No.	l_1 mm	l_2 mm	EAN-No. 4000896+
805-PH 00	40	140	032631
805-PH 0	60	160	032624
805-PH 1	80	180	032648

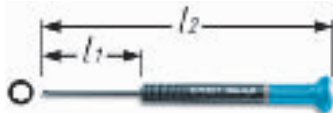

- **For inside hexagon screws**
- Marking ring orange

HAZET No.	l_1 mm	l_2 mm	EAN-No. 4000896+
806-0,7	40	141	057627
806-0,9	40	141	057634
806-1,3	40	141	057641
806-1,5	52	151	057658
806-2,0	60	160	057665
806-2,5	60	160	057672
806-3,0	60	160	057689

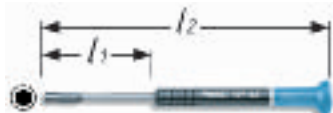

- **For outside hexagon screws**
- Marking ring green

HAZET No.	l_1 mm	l_2 mm	EAN-No. 4000896+
807-2,5	60	160	057696
807-3,0	61	161	057702
807-3,2	60	160	057719
807-3,5	61	161	057726
807-4,0	61	161	057733
807-5,0	60	161	057740
807-5,5	60	160	057757

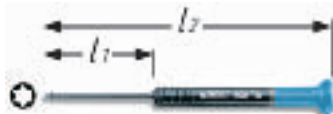

- **For inside TORX® screws**
- Marking ring red

HAZET No.	l_1 mm	l_2 mm	$\frac{1}{4}$ mm	EAN-No. 4000896+
808-T 5	50	150	1,42	057764
808-T 6	50	150	1,67	057771
808-T 7	50	150	1,99	057788
808-T 8	60	160	2,31	057795
808-T 9	60	160	2,50	057801
808-T 10	80	180	2,74	057818
808-T 15	80	180	3,27	057825

Electronic Screwdriver Sets



- For slotted and Phillips-Recess screws
- 7 parts
in black plastic box
- contents:
805-015 02 025 03
805-PH00 PH0 PH1

HAZET No.	EAN-No. 4000896+
805/7	032655



- For inside hexagon screws
- 7 parts
- contents:
806-0,7 0,9 1,3 1,5 2,0 2,5 3,0

HAZET No.	EAN-No. 4000896+
806/7	055036



- For outside hexagon screws
- 7 parts
- contents:
807-2,5 3,0 3,2 3,5 4,0 5,0 5,5

HAZET No.	EAN-No. 4000896+
807/7	055043



Electronic Screwdriver Sets

- For inside TORX® screws
- 7 parts

contents:
808-T5 T6 T7 T8 T9 T10 T15

HAZET No.	EAN-No. 4000896+
808/7	055050

Screwdrivers



- With wooden handle
- With square blade passing through the handle

- For slotted screws
- Blade with hex bolster

HAZET No.	l ₁ mm	l ₂ mm	□ mm	⊕ mm	EAN-No. 4000896+
815-1	100	200	5,5	0,8	033096
815-2	125	235	6,5	1,0	033102
815-3	150	270	8,0	1,2	033119
815-4	175	300	10,0	1,6	033126
815-5	200	330	12,0	2,0	033133
815-6	250	380	14,0	2,5	033140



- For Phillips-Recess screws
- From size PH 3 on, blade with hex-bolster

HAZET No.	l ₁ mm	l ₂ mm	⊕ mm	EAN-No. 4000896+
815-PH 1	80	180	-	077885
815-PH 2	100	210	-	077892
815-PH 3	150	265	13	077908
815-PH 4	200	335	16	077915

Screwdriver Set

- 5 parts
contents:
815-1 2 3
815-PH 1 PH2

HAZET No.	EAN-No. 4000896+
815/5	033157

Offset Screwdrivers



- For slotted screws
- Chrome-Vanadium
- Surface chrome-plated
- DIN 5200

HAZET No.	l ₁ mm	l ₂ mm	□ mm	⊕ mm	EAN-No. 4000896+
818-1	90	8,5	3,5	0,6	033164
818-2	125	10,5	5,5	1,0	033171
818-3	150	17,0	8,0	1,2	033188
818-4	175	24,0	10,0	1,6	033195

Offset Screwdrivers



- For Phillips-Recess screws
- DIN 5208

HAZET No.	l ₁ mm	l ₂ mm	EAN-No. 4000896+
819-PH 1 + PH 2	125	20	033201
819-PH 2 + PH 3	150	29	033218

Three-Square Bearing Scrapers



- Tips ground
- Special steel

HAZET No.	l ₁ mm	l ₂ mm	EAN-No. 4000896+
820-1	125	225	033225
820-2	150	260	033232
820-3	195	305	033249

Hollow Three-Square Scrapers

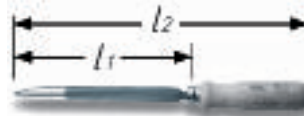

tips ground

HAZET No.	l ₁ mm	l ₂ mm	EAN-No. 4000896+
821-1	150	260	033683
821-2	200	315	033690

Angle Scrapers

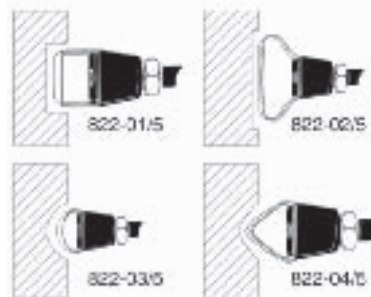

- For removal of underseal (esp. PVC), antidrumming compound, joint sealant, stickers, etc.
- With replaceable and reversible blades made of HSS bimetal – shape of blades see above –
- Chrome-Vanadium
- Surface chrome-plated

HAZET No.	b mm	l mm	EAN-No. 4000896+
-----------	------	------	------------------

Handle only with blade 822-01 (flat)

822	20	270	033713
-----	----	-----	--------

Blade Sets

(5 parts per set)
cardboard packed

822-01/5	20	-	033720
822-02/5	42	-	033744
822-03/5	21,5 / r 12,5	-	033751
822-04/5	21 / 110°	-	033768

Fine Three-Square Scraper



- With protective coating made of viscoplastic and impact-resistant plastic material
- With protection cap
- Special steel

HAZET No.	l ₁ mm	l ₂ mm	EAN-No. 4000896+
823	25	148	033874

Blunt Scrapers

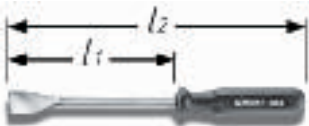

- For the removal of sealing residues
- **824 long blade**
824-1 short blade
- Special steel
- Surface galvanized

HAZET No.	l ₁ mm	l ₂ mm	EAN-No. 4000896+
824	23	150	033881
824-1	23	55	033898



with replaceable hard-metal tip, to be used on both sides

HAZET No.	l ₁ mm	l ₂ mm	EAN-No. 4000896+
825-25	25	267	033959

Interchangeable Hard-Metal Tips

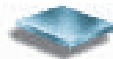

HAZET No.	l ₁ mm	EAN-No. 4000896+
825-025	25	033928

Screwdrivers

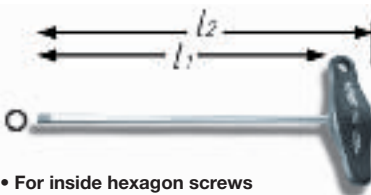

- For inside hexagon screws
- With ergonomic T-handle
- Chrome-Vanadium
- Surface chrome-plated

HAZET No.	l ₁ mm	l ₂ mm	S mm	EAN-No. 4000896+
828- 2	100	118	2,0	034123
828- 2,5	110	118	2,5	034130
828- 3	150	168	3,0	034161
828- 4	150	175	4,0	034192
828- 5	200	232	5,0	034222
828- 6	200	232	6,0	034246
828- 8	200	235	8,0	034260
828-10	200	235	10,0	034109

TORX® Screwdrivers

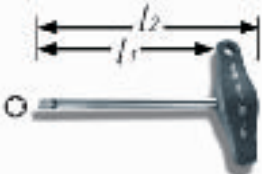

TORX® Screwdrivers

- For inside TORX® screws
- With ergonomic T-handle
- Chrome-Vanadium
- Surface chrome-plated tips burnished

HAZET No.	l ₁ mm	l ₂ mm	Ø mm	EAN-No. 4000896+
828-T 6	80	98	1,67	034451
828-T 7	80	98	1,99	034468
828-T 8	80	98	2,31	034475
828-T 9	80	98	2,50	034482
828-T 10	100	125	2,74	034291
828-T 15	100	125	3,27	034307
828-T 20	100	125	3,86	034321
828-T 25	110	142	4,43	034345
828-T 27	120	152	4,99	034376
828-T 30	130	162	5,52	034383
828-T 40	130	162	6,65	034413
828-T 45	130	165	7,82	034420
828-T 50	130	165	8,83	034437

5-Star Screwdriver



- For the screws at the brand-label on tail gate of SEAT-Cordoba and Ibiza
- With special 5-star profile

HAZET No.	l ₁ mm	l ₂ mm	EAN-No. 4000896+
838-5	98	199	035663

Voltmeters



- 220-250 V according to standard VDE 0680
- Slotted blade, concave ground
- Extra long handle, 92 mm
- With clip
- Defective glow tube not replaceable according to VDE

HAZET No.	l ₁ mm	l ₂ mm	EAN-No. 4000896+
839-1	58	150	035670
839-2	61	150	080441

Screw Extractors



- For turning out worn screws and bolts with right-handed thread
- Polished
- Chrome-Vanadium

HAZET No.	Ø mm	EAN-No. 4000896+
840-1	1,4- 3,6	035687
840-2	2,1- 4,9	035694
840-3	3,1- 6,5	035700
840-4	4,8- 8,8	035717
840-5	6,2-11,0	035724
840-6	9,4-15,0	035731
840-7	12,7-19,0	035748
840-8	17,5-24,0	035755

Screw Extractor Sets



in plastic boxes

HAZET No.	EAN-No. 4000896+
5 parts	
contents: 840-1 2 3 4 5	
840/5	035762
8 parts	
contents: 840-1 2 3 4 5 6 7 8	
840/8	035786

Screw and Stud Extractor Set



Tapping sleeve	Drill-Ø mm	Stud extractor	Suitable for
841- 06	4	841-016	M 5 3/16"
841- 07	4	841-016	M 6 9/32" 1/4"
841- 08	4	841-016	M 7 9/32"
841- 09	4	841-016	M 8 5/16"
841-010	5	841-017	M 8 5/16"
841-011	5	841-017	M 9 11/32"
841-012	5	841-017	M10 3/8"
841-013	6	841-018	M11 7/16"
841-014	7,5	841-019	M12 19/32"
841-015	8,5	841-020	M14 9/16"

- For turning out worn bolts and screws
- Ø 6 to 15 mm
- Application:
 1. Open by boring with drill and tapping sleeve
 2. Insert milled stud extractor
 3. Put on the union nut and turn out the worn bolt or screw
- Special steel
- Surface burnished

HAZET No.	EAN-No. 4000896+
-----------	------------------

Set with 25 parts in plastic box

841/25	060993
--------	--------

Union nuts	
841-01	074433
841-02	074440
841-03	074457
841-04	074464
841-05	074471

Tapping sleeves	
841- 06	074488
841- 07	074495
841- 08	074501
841- 09	074518
841-010	074525
841-011	074532
841-012	074549
841-013	074556
841-014	074563
841-015	074570

Stud extractors	
841-016	074587
841-017	074594
841-018	074600
841-019	074617
841-020	074624

Stud Extractors



12.5 1/2

- For installing and removing stud bolts and set screws with right-handed or left-handed thread without damaging
- □ drive 12.5 = 1/2" or s 21 mm outside hexagon
- Chrome-Vanadium
- Surface chrome-plated and polished

HAZET No.	d mm	l mm	EAN-No. 4000896+
844-6	23,6	65	035823
844-7	23,6	65	035830
844-8	23,6	65	035847
844-10	27,0	75	035809
844-12	27,0	75	035816

Stud Extractor Sets



E 12.5 1/2

- In black plastic box
- With PUR foam insert

HAZET No.	EAN-No. 4000896+
4 parts	
contents: 844-6 8 10 12	
844/4	035854
5 parts	
contents: 844-6 7 8 10 12	
844/5	035878

Stud Extractor



- For turning in and out stud bolts (set screws) with right-handed or left-handed thread
- Special steel
- Surface galvanized

HAZET No.	∅ mm	EAN-No. 4000896+
845	5-19	035892

Hydraulic Nut Splitters



- For splitting tight nuts of the quality ranges 5, 6, 8 and 10
- Special steel

HAZET No.	∅ mm	EAN-No. 4000896+
846-22	7-22	035922
846-36	22-36	035939

Hydraulic Nut Splitters



HAZET No.	EAN-No. 4000896+
Chisel and anvil (counterpart) for 846-22	
846-103	035908
ditto for 846-36	
846-203	035915
Spare chisel for 846-22	
846-022	058006
ditto for 846-36	
846-036	057993

Mechanical Nut Splitters

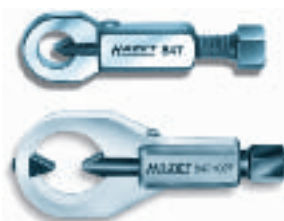

- For splitting tight nuts of the quality ranges 5, 6 and 8
 - With double splitting effect due to 2 chisels
- * = with 1 chisel

HAZET No.	∅ mm	EAN-No. 4000896+
847-0410 *	4-10	050628
847-1027	10-27	035953
847-1736	17-36	035977



Spare chisel for 847-0410		
847-04	-	057986
Chisel, small and large for 847-1027		
847-10	-	035946
ditto for 847-1736		
847-17	-	035960

Flare Nut Insert Tools 12-Point



- Crowfoot Wrench
- For union nuts and tube connections
- Metric sizes

HAZET No.	∅ mm	EAN-No. 4000896+
848 Z-10	6.3 1/4	079049
848 Z-12	6.3 1/4	079056
848 Z-13	6.3 1/4	079063
848 Z-14	6.3 1/4	079070
848 Z-16	10 3/8	079087
848 Z-17	10 3/8	079094
848 Z-18	10 3/8	079100
848 Z-19	10 3/8	079117

Flare Nut Insert Tools 12-Point

HAZET No.	∅ mm	EAN-No. 4000896+
848 Z-21	10 3/8	079124
848 Z-22	10 3/8	079131
848 Z-24	10 3/8	079148
848 Z-26	10 3/8	079155
848 Z-27	10 3/8	079162
848 Z-30	12.5 1/2	079179
848 Z-32	12.5 1/2	079186
848 Z-36	12.5 1/2	079193
848 Z-41	12.5 1/2	079216
848 Z-46	12.5 1/2	079223



- Crowfoot Wrench
- For union nuts and pipe connections
- American sizes

HAZET No.	∅ mm	EAN-No. 4000896+
848 AZ-3/8	6.3 1/4	079230
848 AZ-7/16	6.3 1/4	079247
848 AZ-1/2	6.3 1/4	079254
848 AZ-9/16	6.3 1/4	079285
848 AZ-5/8	10 3/8	079292
848 AZ-11/16	10 3/8	079308
848 AZ-3/4	10 3/8	079315
848 AZ-13/16	10 3/8	079322
848 AZ-7/8	10 3/8	079339
848 AZ-15/16	10 3/8	079346
848 AZ-1	10 3/8	079353
848 AZ-1 1/16	10 3/8	079360
848 AZ-1 1/8	12.5 1/2	079377
848 AZ-1 1/4	12.5 1/2	079384
848 AZ-1 5/16	12.5 1/2	079391
848 AZ-1 3/8	12.5 1/2	079407
848 AZ-1 7/16	12.5 1/2	079414
848 AZ-1 1/2	12.5 1/2	079421
848 AZ-1 9/16	12.5 1/2	079445
848 AZ-1 5/8	12.5 1/2	079452
848 AZ-1 3/4	12.5 1/2	079469
848 AZ-1 13/16	12.5 1/2	079476
848 AZ-2	12.5 1/2	079483
848 AZ-2 1/4	12.5 1/2	079490
848 AZ-2 5/16	12.5 1/2	079506
848 AZ-2 3/8	12.5 1/2	079513



Tap and Die Set

(E)



- For problem-free **rethreading** even in areas with restricted access
- To be used with Reversible Ratchet
- Heavy-duty thread cutter made of HSS steel
- In black plastic box
- With PUR foam insert
- DBGM – German registered utility model

Tap and Die Set

(E)

contents:
849 IG- M3 M4 M5 M6 M8 M10 M12
849 AG-M3 M4 M5 M6 M8 M10 M12
849 IG-6,3 8 849 AG-6,3 10
2100-025 2250-1 3

HAZET No.	EAN-No. 4000896+
849	035984

SPARE PARTS

HAZET No.	EAN-No. 4000896+
-----------	------------------

Taps for female threads

849 IG-M 3	036127
849 IG-M 4	036134
849 IG-M 5	036141
849 IG-M 6	036158
849 IG-M 8	036165
849 IG-M 10	036103
849 IG-M 12	036110

Dies for male threads

849 AG-M 3	036035
849 AG-M 4	036042
849 AG-M 5	036059
849 AG-M 6	036066
849 AG-M 8	036073
849 AG-M 10	036011
849 AG-M 12	036028

Spare parts

HAZET No.	EAN-No. 4000896+
-----------	------------------

Chuck

● 6.3 = 1/4",
for Taps 849 IG-M 3 up to M 6
(in conjunction with Adapter 2250-1)

849 IG-6,3	036080
------------	--------

Chuck

● 8 = 5/16",
for Taps 849 IG-M 8 up to M 12
(in conjunction with Adapter 2250-3)

849 IG-8	036097
----------	--------

Die Stock

□ drive 6.3 = 1/4",
for Dies 849 AG-M 3 up to M 6

849 AG-6,3	036004
------------	--------

Die Stock

□ drive 10 = 3/8",
for Dies 849 AG-M 8 up to M 12

849 AG-10	035991
-----------	--------

Adapter

for Dies according to DIN EN 22568
in connection with 849 AG-6,3 -10

849 AG-20	061105
-----------	--------

849 AG-30	061112
-----------	--------

849 AG-38	061129
-----------	--------

2100-025	011285
----------	--------

2250-1	015443
--------	--------

2250-3	015474
--------	--------

HAZET-Sockets – the correct tool for any application

✓ All sizes available 6.3 1/4" 10 3/8" 12.5 1/2" 20 3/4" 25 1"

✓ Suitable for manual and impact operation

✓ HAZET traction profile

- Large contact surface between tool and screw
- Prevents edge wear of sockets
- Protects tool and screw
- Enables operating damaged screws
- 20% higher torque values

6-Point Sockets



- □ drive 6.3 = 1/4"
- With Traction profile
- Handy and milled
- For manual operation
- Chrome-Vanadium
- Surface chrome-plated, polished
- DIN 3124, ISO 2725-1

HAZET No.	l mm	d ₁ mm	d ₂ mm	t mm	EAN-No. 4000896+
850- 3	25	6,2	11,0	3,2	057221
850- 3,2	25	6,2	11,0	3,2	036363
850- 4	25	6,8	11,0	3,7	036370
850- 4,5	25	7,0	11,0	4,2	036387
850- 5	25	8,0	11,0	4,1	036400
850- 5,5	25	8,5	11,0	4,6	036417
850- 6	25	9,0	11,0	5,1	036479
850- 7	25	10,5	11,5	5,6	036516
850- 8	25	11,5	12,5	6,3	036547
850- 9	25	13,0	11,5	7,3	036585
850-10	25	14,0	12,5	7,3	036202
850-11	25	15,5	14,0	8,3	036240

6-Point Sockets

HAZET No.	l mm	d ₁ mm	d ₂ mm	t mm	EAN-No. 4000896+
850-12	25	17,0	15,0	9,3	036271
850-13	25	18,0	15,0	9,3	036301
850-14	25	19,5	16,0	10,8	036349

- American sizes
- □ drive 6.3 = 1/4"
- With Traction profile
- Handy and milled
- For manual operation
- Chrome-Vanadium
- Surface chrome-plated, polished

HAZET No.	l mm	d ₁ mm	d ₂ mm	t mm	EAN-No. 4000896+
850 A-3/16	25	8,0	11,0	4,2	037490
850 A-7/32	25	8,5	11,0	4,6	037537
850 A-1/4	25	9,5	11,0	5,1	037476
850 A-9/32	25	10,5	11,5	5,6	037551
850 A-5/16	25	11,5	12,5	6,3	037513
850 A-11/32	25	13,0	11,5	7,3	037483
850 A-3/8	25	14,0	12,5	7,3	037506
850 A-7/16	25	15,5	14,0	8,3	037520
850 A-1/2	25	18,0	15,0	9,3	037469
850 A-9/16	25	19,5	16,0	10,8	037544

12-Point Sockets



- American sizes
- □ drive 6.3 = 1/4"
- With Traction profile
- Handy and milled
- For manual operation
- Chrome-Vanadium
- Surface chrome-plated, polished

HAZET No.	l mm	d ₁ mm	d ₂ mm	t mm	EAN-No. 4000896+
850 AZ-3/16	25	7,4	11,0	4,2	078462
850 AZ-7/32	25	8,7	11,0	4,7	078479
850 AZ-1/4	25	9,3	11,0	5,1	078486
850 AZ-9/32	25	10,9	11,5	5,5	078493
850 AZ-5/16	25	12,0	12,5	6,5	078516
850 AZ-11/32	25	13,4	11,5	7,5	078523
850 AZ-3/8	25	14,5	12,5	7,4	078530
850 AZ-7/16	25	15,5	14,0	8,3	078547
850 AZ-1/2	25	17,6	15,0	9,3	078554
850 AZ-9/16	25	19,5	16,0	10,7	078561

6-Point Sockets



- Long style
- □ drive 6.3 = 1/4"
- **With Traction profile**
- Handy and milled
- For manual operation
- Chrome-Vanadium
- Surface chrome-plated, polished

HAZET No.	l mm	d ₁ mm	d ₂ mm	t min. mm	EAN-No. 4000896+
850 Lg- 4	50	6,7	11,0	3,8	037643
850 Lg- 5	50	7,9	11,0	4,4	037650
850 Lg- 5,5	50	8,5	11,0	4,7	037667
850 Lg- 6	50	9,2	11,0	5,0	037674
850 Lg- 7	50	11,0	11,0	5,5	037681
850 Lg- 8	50	12,0	12,0	6,0	037698
850 Lg- 9	50	13,0	13,0	6,5	037704
850 Lg-10	50	14,5	14,5	7,0	037599
850 Lg-11	50	15,5	15,5	7,5	037605
850 Lg-12	50	17,0	17,0	8,0	037612
850 Lg-13	50	18,0	18,0	8,5	037629

12-Point Sockets

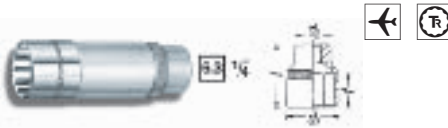

- Long style
- American sizes
- □ drive 6.3 = 1/4"
- **With Traction profile**
- Handy and milled
- For manual operation
- Chrome-Vanadium
- Surface chrome-plated, polished

HAZET No.	l mm	d ₁ mm	d ₂ mm	t mm	EAN-No. 4000896+
850 TAZ-3/16	50	7,4	11,0	4,70	078578
850 TAZ-7/32	50	8,7	11,0	5,20	078585
850 TAZ-1/4	50	9,3	11,0	5,60	078592
850 TAZ-9/32	50	10,8	11,0	6,10	078608
850 TAZ-5/16	50	11,4	11,6	8,00	078615
850 TAZ-11/32	50	13,0	13,0	8,00	078622
850 TAZ-3/8	50	14,2	14,2	9,46	078639
850 TAZ-7/16	50	15,5	15,5	10,90	078646
850 TAZ-1/2	50	17,5	17,5	12,40	078653
850 TAZ-9/16	50	19,3	19,3	15,20	078660

12-Point Sockets



- With hinge joint
- For areas with restricted access
- American sizes
- □ drive 6.3 = 1/4"
- Chrome-Vanadium
- Surface chrome-plated, polished

HAZET No.	l mm	d ₁ mm	d ₂ mm	t mm	EAN-No. 4000896+
850 G AZ-1/4	32,5	13	9,6	5,6	078677
850 G AZ-3/16	35,0	13	11,5	7,0	078684
850 G AZ-3/8	37,0	13	13,5	8,5	078691
850 G AZ-7/16	40,0	13	15,0	9,9	078707
850 G AZ-1/2	42,0	13	17,0	9,3	078714

TORX® Sockets



- □ drive 6.3 = 1/4"
- For outside TORX® screws
- Handy and milled
- For manual operation
- Chrome-Vanadium
- Surface chrome-plated, polished

HAZET No.	l mm	d ₁ mm	d ₂ mm	EAN-No. 4000896+	
850-E 4	3,86	25	5,6	11,0	036653
850-E 5	4,75	25	6,7	11,0	036684
850-E 6	5,74	25	8,0	11,0	036714
850-E 7	6,22	25	9,6	11,0	036745
850-E 8	7,52	25	10,5	11,5	036776
850-E 10	9,42	25	13,0	12,0	036615
850-E 11	10,08	25	14,0	12,5	036646

Screwdriver Sockets



- □ drive 6.3 = 1/4"
- For inside hexagon screws
- Handy and milled
- For manual operation
- Chrome-Vanadium
- **Surface CVD-Titannitrite (TIN) coated for**
 - Improved endurance
 - Higher torque values
 - Corrosion-resistant
 - Minimization of Cam-Out effect (Better screw grip)
- DIN 7422

8501-2,5 esp. for screwing the headliner and cape hood bracing wires, micrositches, soft top frames BMW E 38 Convertible, 3 series Convertible

HAZET No.	d mm	l ₁ mm	l ₂ mm	EAN-No. 4000896+
8501-2,5	12	6,5	28	036837
8501-3	12	6,5	28	036851
8501-4	12	6,5	28	036875
8501-5	12	6,5	28	036899
8501-6	12	6,5	28	036912
8501-8	12	6,5	28	036936

TORX® Screwdriver Sockets



- □ drive 6.3 = 1/4"
- For inside TORX® screws
- Handy and milled
- For manual operation
- Chrome-Vanadium
- Surface CVD-Titannitrite (TIN) coated

HAZET No.	l ₁ mm	l ₂ mm	d mm	EAN-No. 4000896+	
8502-T 8	2,31	3,5	28	12	037124
8502-T 9	2,50	3,5	28	12	037148
8502-T 10	2,74	3,8	28	12	036967
8502-T 15	3,27	4,0	28	12	036981
8502-T 20	3,86	4,0	28	12	037001
8502-T 25	4,43	4,5	28	12	037025
8502-T 27	4,99	4,5	28	12	037049
8502-T 30	5,52	5,0	28	12	037063
8502-T 40	6,65	2,0	28	12	037100

Screwdriver Sockets



- □ drive 6.3 = 1/4"
- For slotted screws
- Handy and milled
- For manual operation
- Chrome-Vanadium
- Surface CVD-Titannitrite (TIN) coated

HAZET No.	l ₁ mm	l ₂ mm	d mm	EAN-No. 4000896+
8503-0,6 x 3,5	16	28	12	037162
8503-0,8 x 4	16	28	12	037186
8503-1 x 5,5	16	28	12	037247
8503-1,2 x 8	16	28	12	037209
8503-1,6 x 10	16	28	12	037223



- □ drive 6.3 = 1/4"
- For Phillips-Recess screws
- Handy and milled
- For manual operation
- Chrome-Vanadium
- Surface CVD-Titannitrite (TIN) coated

HAZET No.	l ₁ mm	l ₂ mm	d mm	EAN-No. 4000896+
8506-PH 1	16	28	12	037285
8506-PH 2	16	28	12	037308
8506-PH 3	16	28	12	037322
8506-PH 4	16	28	12	037346



- □ drive 6.3 = 1/4"
- For Pozidriv® screws
- Handy and milled
- For manual operation
- Chrome-Vanadium
- Surface CVD-Titannitrite (TIN) coated

HAZET No.	l ₁ mm	l ₂ mm	d mm	EAN-No. 4000896+
8507-PZ 1	16	28	12	037360
8507-PZ 2	16	28	12	037377
8507-PZ 3	16	28	12	037384

Adapter



- □ drive 6.3 = 1/4"
- ■ drive 10 = 3/8"
- Chrome-Vanadium
- Surface chrome-plated
- DIN 3123, ISO 3316

HAZET No.	l mm	EAN-No. 4000896+
858-1	26,5	038480

Fine-Tooth Reversible Ratchet

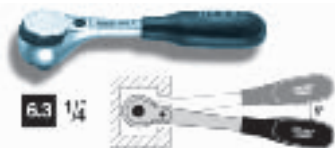

- drive 6.3 = 1/4"
- With 72 teeth, **actuation angle 5°**, enable working in areas with restricted access
- One-hand operation
- Chrome-Vanadium
- Surface chrome-plated

HAZET No.	l / mm	EAN-No. 4000896+
863 F	115	061471

»Komposit« Reversible Ratchet



- drive 6.3 = 1/4"
- With locking device and quick-release press-button by pressing the button, attached tools are easily released – with just one hand
- Change-over switch on handle enables one-hand operation
- Components are easily replaceable due to "Komposit" construction
- Shock resistant plastic body
- Ergonomic design
- Smooth-running ratchet wheel (20 teeth)
- Safe locking of the Sockets
- Chrome-Vanadium
- Cover plates made of chrome-plated steel
- DIN 3122, ISO 3315
- DBP

HAZET No.	l / mm	EAN-No. 4000896+
863 N	122	038527

Reversible Ratchets



- drive 6.3 = 1/4"
- Ratchet wheel 20 teeth
- Chrome-Vanadium
- Surface chrome-plated, polished
- DIN 3122, ISO 3315

HAZET No.	l / mm	EAN-No. 4000896+
863 P	115	038558



- drive 6.3 = 1/4"
- With locking device and quick-release press-button by pressing the button, attached tools are easily released – with just one hand
- Ratchet wheel 20 teeth
- Safe locking of the Sockets
- Chrome-Vanadium
- Surface chrome-plated, heads polished

HAZET No.	l / mm	EAN-No. 4000896+
863 S	115	038626

Reversible Ratchets



- drive 6.3 = 1/4"
- Curved design for working in areas with restricted access
- Ratchet wheel 20 teeth
- Chrome-Vanadium
- Surface chrome-plated, polished
- DIN 3122, ISO 3315

HAZET No.	l / mm	EAN-No. 4000896+
863 PC	115	038602



- drive 6.3 = 1/4"
- With hinge joint for working in areas with restricted access
- Ratchet wheel 20 teeth
- Chrome-Vanadium
- Surface chrome-plated, polished
- DIN 3122, ISO 3315

HAZET No.	l / mm	EAN-No. 4000896+
863 G	135	038497

Reversible Ratchet with T-Handle



- drive 6.3 = 1/4"
- Tool combines the advantages of a T-Handle and a Reversible Ratchet
- Enables either powerful or sensitive working
- With quick-release press-button
- **Optimal working with Extension HAZET 868**
- DIN 3122, ISO 3315

HAZET No.	EAN-No. 4000896+
863 Q	063482



Spare Parts for Reversible Ratchets



HAZET No.	EAN-No. 4000896+
-----------	------------------

Repair Set for shift lever
consisting of: shift lever, screws, ball, compression spring for 863, 863 G, 863 P, 863 PC, 863 Q, 863 S, 863 ST, 2264

863 P/5	038589
---------	--------

Repair Set for ratchet wheel 6.3 = 1/4"
consisting of: ratchet wheel, pawl, shift lever, screws, ball, compression spring for 863 G, 863 P, 863 PC

863 P/7 N	038596
-----------	--------

Repair Set for ratchet wheel 6.3 = 1/4"
consisting of: ratchet wheel with quick-release press-button, pawl, cap screws, 1 holding down bolt each (small and large), for 863 N

863 N/6	038541
---------	--------

Repair Set for ratchet wheel 6.3 = 1/4"
consisting of: ratchet wheel, pawl, shift lever, screws, ball, compression spring for 863 Q, 863 S

863 S/7	048472
---------	--------

Flexible Handle



- drive 6.3 = 1/4"
- Chrome-Vanadium
- Surface mat chrome-plated
- DIN 3122, ISO 3315

HAZET No.	l / mm	EAN-No. 4000896+
864	143	038688

Sliding T-Handle



- drive 6.3 = 1/4"
- Chrome-Vanadium
- Surface chrome-plated, polished
- DIN 3122, ISO 3315

HAZET No.	l / mm	EAN-No. 4000896+
865	115	038718

Spin Type Speeder TRInamicULTRA



- drive 6.3 = 1/4"
- TRInamicULTRA handle
- Best possible connection of hand and handle due to "Haptik" elements
- Antislipping even with greasy hands
- Chrome-Vanadium
- Surface mat chrome-plated
- DIN 3122, ISO 3315

HAZET No.	l / mm	EAN-No. 4000896+
866 U	134	056453

Extensions



- □ ■ drive 6.3 = 1/4"
- Chrome-Vanadium
- Surface chrome-plated, polished
- DIN 3123, ISO 3316

HAZET No.	l mm	EAN-No. 4000896+
867-1	25,0	038732
867-2	55,0	038749
867-4	101,5	038770



- □ ■ drive 6.3 = 1/4"
- Chrome-Vanadium
- Surface chrome-plated, polished
- DIN 3123, ISO 3316

HAZET No.	l mm	EAN-No. 4000896+
868	147	038794
868-16	402	076727

Universal Joint



- □ ■ drive 6.3 = 1/4"
- Enables getting over obstacles and troublesome borders
- Chrome-Vanadium
- Surface chrome-plated
- DIN 3123, ISO 3316

HAZET No.	l mm	EAN-No. 4000896+
869	36,5	038824

Flexible Extensions



- ■ drive 6.3 = 1/4"
- Flexible shaft enables getting over obstacles and borders and fast working even in areas with restricted access
- Chrome-Vanadium

HAZET No.	l mm	EAN-No. 4000896+
870	150	038848

with handle
esp. for worm drive hose clips
in fuel lines and coolant hoses, etc.

870-2	130	050536
-------	-----	--------

Wobble Extensions



- □ ■ drive 6.3 = 1/4"
- With ball shaped, conical outside square drive, allows 8° angular movement to every side
- Wobble Extension can also be used as rigid connection by attaching a socket until the limit stop is reached

Wobble Extensions

- Flexible shaft enables getting over obstacles and borders in areas with restricted access
- Chrome-Vanadium
- Surface chrome-plated, polished

HAZET No.	l mm	EAN-No. 4000896+
871-1	25	038855
871-4	101,5	038879

Locking Adapter



- □ ■ drive 6.3 = 1/4"
- Eliminates the risk of socket loss in areas with restricted access
- Easy and quick releasing of tool by pulling back the knurled ring
- Chrome-Vanadium
- Surface chrome-plated, polished

HAZET No.	l mm	EAN-No. 4000896+
872	41,8	053049

Socket Sets (6-Point)



(E) 6.3 1/4"

- □ drive 6.3 = 1/4"
 - In plastic box
 - With PUR foam insert – all tools are snugly embedded
 - 14 parts
- contents:
850-4 4,5 5 5,5 6 7 8 9 10 11
865 866 U 867-2 868

HAZET No.	EAN-No. 4000896+
850	036189



(E) 6.3 1/4"

- □ drive 6.3 = 1/4"
 - In plastic box
 - With PUR foam insert – all tools are snugly embedded
 - 14 parts
- contents:
850-4 4,5 5 5,5 6 7 8 9 10 11
863 P 867-2 868 869

HAZET No.	EAN-No. 4000896+
850-1	036196

TORX® Socket Set

(E) 6.3 1/4"



- □ drive 6.3 = 1/4"
- With Reversible Ratchet with T-Handle
- In plastic box
- With PUR foam insert – all tools are snugly embedded
- 20 parts

contents:
850-E4 E5 E6 E7 E8 E10 E11
8502-T 8 T 9 T10 T15 T20
T25 T27 T30 T40
863 Q 868 871-4 869

HAZET No.	EAN-No. 4000896+
850 TQ	072033

Socket Sets (6-Point)



(E) 6.3 1/4"

- □ drive 6.3 = 1/4"
- In plastic box
- With PUR foam insert – all tools are snugly embedded
- 14 parts

contents:
850-5 5,5 6 7 8 9 10 11 12 13
863 P 867-2 868 869

HAZET No.	EAN-No. 4000896+
851	038176



(E) 6.3 1/4"

- □ drive 6.3 = 1/4"
- In plastic box
- With PUR foam insert – all tools are snugly embedded
- 16 parts

contents:
850-4 4,5 5 5,5 6 7 8 9 10 11
863 P 865 866 U 867-2 868 869

HAZET No.	EAN-No. 4000896+
852 N	038299

Socket Sets (6-Point)



187 x 125 x 39

(E) 6.3 1/4"

- drive 6.3 = 1/4"
- In plastic box
- With PUR foam insert – all tools are snugly embedded
- 20 parts

contents:
850-4 4,5 5 5,5 6 7 8
9 10 11 12 13 14
863 P 864 865
866 U 867-2 868 869

HAZET No.	EAN-No. 4000896+
852-1	038220

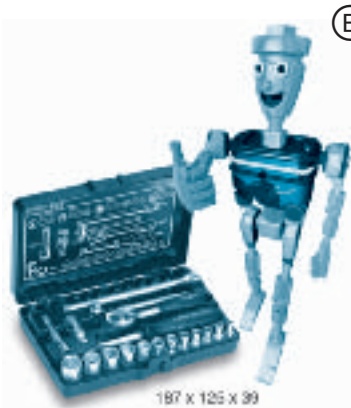

187 x 125 x 39

(E) 6.3 1/4"

- drive 6.3 = 1/4"
- With Screwdriver Sockets CVD-Titannitrite (TIN) coated
- In plastic box
- With PUR foam insert – all tools are snugly embedded
- 30 parts

contents:
850-4 5 5,5 6 7 8
9 10 11 12 13 14
8501-3 4 5 6 8
8503-0,6x3,5 1x5,5 1,2x8
8506-PH1 PH2
8507-PZ1 PZ2
863 P 865 866 U
867-2 868 869

HAZET No.	EAN-No. 4000896+
854	038336



187 x 125 x 39

(E) 6.3 1/4"

- drive 6.3 = 1/4"
- With Screwdriver Sockets CVD-Titannitrite (TIN) coated
- In plastic box
- With PUR foam insert – all tools are snugly embedded

Socket Sets (6-Point)

• 33 parts
contents:
850-4 5 6 7 8 9
10 11 12 13 14
8501-3 4 5 6 8
8503-0,6x3,5 0,8x4 1x5,5 1,2x8
8506-PH1 PH2 PH3 PH4
8507-PZ1 PZ2 PZ3
863 P 865 866 U
867-2 868 869

HAZET No.	EAN-No. 4000896+
854-1	038343



187 x 125 x 39

(E) 6.3 1/4"

- drive 6.3 = 1/4"
- With Fine-Tooth Reversible Ratchet, 72 teeth
- With Screwdriver Sockets CVD-Titannitrite (TIN) coated
- In plastic box
- With PUR foam insert – all tools are snugly embedded
- 30 parts

contents:
850-4 5 5,5 6 7 8
9 10 11 12 13 14
8501-3 4 5 6 8
8503-0,6x3,5 1x5,5 1,2x8
8506-PH1 PH2
8507-PZ1 PZ2
863 F 865 866 U
867-2 868 869

HAZET No.	EAN-No. 4000896+
854 F	061235

(E) 6.3 1/4"



- Drive 6.3 = 1/4"
- Screwdriver Sockets, CVD TIN coated
- In plastic box
- With PUR foam insert – all tools are snugly embedded
- 33 parts:

contents:
850-5 5,5 6 7 8 9
10 11 12 13 14
850-E5 E6 E7 E8 E10
8501-3 4 5 6
8502-T10 T15 T20 T25 T30
8503-1x5,5 8506-PH2
863 P 871-4 866 U
867-2 868 869

HAZET No.	EAN-No. 4000896+
854 T	109579

Socket Sets (6-Point)



275 x 121 x 47

(E) 6.3 1/4"

- drive 6.3 = 1/4"
- With Screwdriver Sockets, long style
- In plastic box
- With PUR foam insert – all tools are snugly embedded
- 13 parts

contents:
850 Lg-4 5 5,5 6 7 8
9 10 11 12 13
863 G 867-4

HAZET No.	EAN-No. 4000896+
855	038442

Socket Set (12-Point)



187 x 97 x 37

(E) 6.3 1/4"

- drive 6.3 = 1/4"
- American sizes
- In plastic box
- With PUR foam insert – all tools are snugly embedded
- 14 parts

contents:
850 AZ-3/16 7/32 1/4 9/32 5/16 11/32 3/8 7/16 1/2 9/16
863 S 867-2 868 869

HAZET No.	EAN-No. 4000896+
851 AZ	084814

Socket Sets (6-Point)



187 x 125 x 39

(E) 6.3 1/4"

- drive 6.3 = 1/4"
- American sizes
- In plastic box
- With PUR foam insert – all tools are snugly embedded
- 14 parts

contents:
850 A-3/16 7/32 1/4 9/32 5/16 11/32 3/8 7/16
863 P 865 866 U 867-2 868 869

HAZET No.	EAN-No. 4000896+
852 A N	038275

Socket Sets (6-Point)



(E) 6.3 1/4"

- drive 6.3 = 1/4"
- American sizes
- In plastic box
- With PUR foam insert – all tools are snugly embedded
- 17 parts

contents:
850 A-3/16 7/32 1/4 9/32 5/16 11/32 3/8 7/16 1/2 9/16
863 P 864 865 866 U 867-2 868 869

HAZET No.	EAN-No. 4000896+
852 A-1	038251

Socket Rails

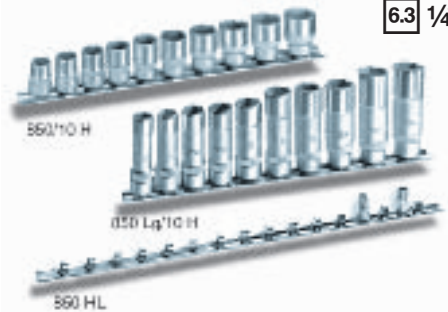

6.3 1/4"

- drive 6.3 = 1/4"
- Easy installation: with 2 bore holes for e.g. wall fixation
- With clips suitable for the corresponding socket drive
- Clear arrangement on rail keeps sockets always ready to hand
- Made of metal

HAZET No.	l mm	EAN-No. 4000896+
10 6-Point Sockets		
contents: 850-4 5 6 7 8 9 10 11 12 13		
850/10 H	430	051748
10 6-Point Sockets, long style		
contents: 850 Lg-4 5 6 7 8 9 10 11 12 13		
850 Lg/10 H	430	051786
empty, with 16 clips suitable for Sockets 850		
850 HL	430	037575

6-Point Sockets



- drive 10 = 3/8"
- With Traction profile**
- Handy and milled
- For manual operation
- Chrome-Vanadium
- Surface chrome-plated, polished
- DIN 3124, ISO 2725

6-Point Sockets

* = not according to DIN

HAZET No.	l mm	d ₁ mm	d ₂ mm	t mm	EAN-No. 4000896+
880-6*	24,0	10,0	17,0	6,2	039104
880-7	24,0	10,5	17,0	6,2	039111
880-8	24,0	11,8	17,0	6,2	039128
880-9	24,0	13,0	17,0	6,2	039135
880-10	25,0	14,4	17,0	7,2	038893
880-11	26,0	15,8	17,5	8,2	038916
880-12	27,0	17,0	18,5	9,2	038923
880-13	27,5	18,4	17,0	9,7	038930
880-14	29,5	19,5	17,5	11,7	038947
880-15	29,5	20,9	18,0	11,7	038954
880-16	29,5	22,1	18,0	11,7	038961
880-17	29,5	23,3	18,5	11,7	038978
880-18	31,5	24,8	19,0	13,5	038992
880-19	31,5	25,8	19,5	13,5	039005
880-20	31,5	26,8	21,0	13,5	039043
880-21	31,5	28,3	22,5	13,0	039050
880-22	34,0	29,6	23,5	16,0	039067

- American sizes
- drive 10 = 3/8"
- With Traction profile**
- Handy and milled
- For manual operation
- Chrome-Vanadium
- Surface chrome-plated, polished

HAZET No.	l mm	d ₁ mm	d ₂ mm	t mm	EAN-No. 4000896+
880 A-1/4	24,0	10,0	17,0	6,2	040056
880 A-3/16	24,0	11,8	17,0	6,2	040094
880 A-1/8	25,0	13,8	17,0	7,2	040087
880 A-7/16	26,0	15,8	17,5	8,2	040117
880 A-1/2	27,5	18,4	17,0	9,7	040049
880 A-9/16	29,5	20,1	17,5	11,7	040124
880 A-5/8	29,5	22,1	18,0	11,7	040100
880 A-11/16	29,5	23,8	18,5	11,7	040063
880 A-3/4	31,5	25,8	19,5	14,0	040070



- Long style
- drive 10 = 3/8"
- With Traction profile**
- Handy and milled
- For manual operation
- Chrome-Vanadium
- Surface chrome-plated, polished
- DIN 3124, ISO 2725

HAZET No.	l mm	d ₁ mm	d ₂ mm	t mm	EAN-No. 4000896+
880 Lg-7	54	10,9	17,0	7,0	052240
880 Lg-8	54	12,1	17,0	7,0	052257
880 Lg-9	54	13,0	17,0	10,0	040858
880 Lg-10	54	14,4	17,0	10,0	040698
880 Lg-11	54	15,8	17,2	11,0	040704
880 Lg-12	54	17,0	18,5	11,0	040711
880 Lg-13	54	18,4	18,5	12,0	040728
880 Lg-14	54	19,5	19,5	15,0	040759
880 Lg-15	60	20,8	19,5	15,0	040766
880 Lg-16	60	21,8	18,5	16,0	040773
880 Lg-17	60	23,0	18,5	16,0	040780
880 Lg-18	66	24,4	20,0	20,0	040797
880 Lg-19	66	25,5	20,0	20,0	040803
880 Lg-20	70	26,6	21,0	22,0	040810
880 Lg-20,8 (1 1/16) +	70	27,4	21,0	16,5	040827
880 Lg-21	70	28,0	22,0	22,0	040834
880 Lg-22	70	29,6	21,0	22,0	040841

6-Point Sockets

10 3/8"

- Long style
- American sizes
- drive 10 = 3/8"
- With Traction profile**
- Handy and milled
- For manual operation
- Chrome-Vanadium
- Surface chrome-plated, polished

HAZET No.	l mm	d ₁ mm	d ₂ mm	t mm	EAN-No. 4000896+
880 A Lg-3/8	54	13,8	17,0	10,0	040193
880 A Lg-7/16	54	15,8	17,2	11,0	040216
880 A Lg-1/2	54	18,0	18,5	12,0	040148
880 A Lg-9/16	60	19,8	19,5	15,0	040230
880 A Lg-19/32	60	20,8	19,5	15,0	040179
880 A Lg-5/8	60	21,8	18,5	16,0	040209
880 A Lg-11/16	66	23,5	19,0	20,0	040155
880 A Lg-3/4	66	25,5	20,0	20,0	040186
880 A Lg-13/16 (20,8) +70	27,4	21,0	16,5	040827	
880 A Lg-7/8	70	29,6	21,0	22,0	040223

12-Point Sockets

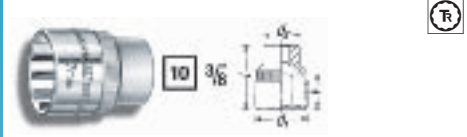

- drive 10 = 3/8"
- With Traction profile**
- Handy and milled
- For manual operation
- Chrome-Vanadium
- Surface chrome-plated, polished
- DIN 3124, ISO 2725

HAZET No.	l mm	d ₁ mm	d ₂ mm	t mm	EAN-No. 4000896+
880 Z-9	24,0	13,0	17,0	6,2	041985
880 Z-10	25,0	14,4	17,0	7,2	041848
880 Z-11	26,0	15,8	17,5	8,2	041855
880 Z-12	27,0	17,0	18,5	9,2	041862
880 Z-13	27,5	18,4	17,0	9,7	041879
880 Z-14	29,5	19,6	17,5	11,7	041893
880 Z-15	29,5	20,9	18,0	11,7	041909
880 Z-16	29,5	22,1	18,0	11,7	041916
880 Z-17	29,5	23,3	18,5	11,7	041923
880 Z-18	31,5	24,6	19,0	13,5	041930
880 Z-19	31,5	25,8	19,5	13,5	041947
880 Z-20	31,5	26,8	20,0	13,5	041954
880 Z-21	31,5	28,3	22,5	13,0	041961
880 Z-22	34,0	29,6	23,5	15,5	041978

- American sizes
- drive 10 = 3/8"
- With Traction profile**
- Handy and milled
- For manual operation
- Chrome-Vanadium
- Surface chrome-plated, polished

HAZET No.	l mm	d ₁ mm	d ₂ mm	t mm	EAN-No. 4000896+
880 AZ-3/8	25,0	13,8	17,0	7,2	040360
880 AZ-7/16	26,0	15,8	17,5	8,2	040384
880 AZ-1/2	27,5	18,7	17,0	9,7	040292
880 AZ-9/16	29,5	20,1	17,5	11,7	040407
880 AZ-19/32	29,5	21,1	18,0	11,7	040339
880 AZ-5/8	29,5	22,1	18,0	11,7	040377
880 AZ-11/16	29,5	23,8	18,5	11,7	040308
880 AZ-3/4	31,5	25,8	19,5	13,0	040353
880 AZ-29/32	31,5	26,8	21,0	13,5	040346
880 AZ-13/16	32,0	28,3	22,5	13,5	040315
880 AZ-7/8	34,0	30,3	23,5	15,5	040391
880 AZ-15/16	36,5	32,3	23,5	17,5	040322

12-Point Sockets



- Long style
- drive 10 = 3/8"
- **With Traction profile**
- Handy and milled
- For manual operation
- Chrome-Vanadium
- Surface chrome-plated, polished
- DIN 3124, ISO 2725-1

* = not according to DIN

+ = with rubber ply for spark plugs

HAZET No.	l mm	d ₁ mm	d ₂ mm	t mm	EAN-No. 4000896+
880 TZ- 9 *	54	13,0	17,0	10,0	041824
880 TZ-10 *	54	14,4	17,0	10,0	041602
880 TZ-11 *	54	15,8	17,2	11,0	041626
880 TZ-12 *	54	17,0	18,5	11,0	041633
880 TZ-13 *	54	18,4	18,5	12,0	041664
880 TZ-14 *	54	19,5	19,5	15,0	041688
880 TZ-15 *	60	20,8	19,5	15,0	041701
880 TZ-16 *	60	21,8	18,5	16,0	041718
880 TZ-17 *	60	23,0	18,5	16,0	041725
880 TZ-18 *	66	24,4	20,0	20,0	041749
880 TZ-19 *	66	25,5	20,0	20,0	041756
880 TZ-20	70	26,6	21,0	22,0	041763
880 TZ-20,8 (1 3/16) +	70	27,4	21,0	16,5	041770
880 TZ-21	70	28,0	22,0	22,0	041794
880 TZ-22	70	29,6	21,0	22,0	041800

6-Point Sockets

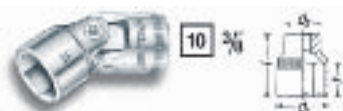

- With hinge joint
- For working in areas with restricted access
- drive 10 = 3/8"
- For manual operation
- Chrome-Vanadium
- Surface chrome-plated, polished

HAZET No.	l mm	d ₁ mm	d ₂ mm	t mm	EAN-No. 4000896+
880 G-10	43	13,8	19	6,8	040414
880 G-11	43	15,0	19	6,8	040438
880 G-12	44	16,6	19	7,3	040445
880 G-13	44	17,8	19	7,3	040452
880 G-14	45	19,0	19	9,3	040469
880 G-15	45	20,4	19	9,3	040476
880 G-16	46	22,0	19	9,2	040483
880 G-17	46	22,8	19	9,2	040490
880 G-18	47	24,5	19	10,2	040506
880 G-19	48	25,2	19	11,2	040513

6-Point Socket Set



- In plastic box
 - With PUR foam insert – all tools are snugly embedded
 - 8 parts
- contents:
880 G-10 11 12 13 14 15 17 19

HAZET No.	EAN-No. 4000896+
880 G/8	040629

TORX® Sockets



- drive 10 = 3/8"
- For outside TORX® screws
- Handy and milled
- For manual operation
- Chrome-Vanadium
- Surface chrome-plated, polished

HAZET No.	l mm	d ₁ mm	d ₂ mm	EAN-No. 4000896+	
880 Lg-E 8	7,52	65	10,5	17,0	053070
880 Lg-E 10	9,42	65	13,0	17,0	053087
880 Lg-E 11	10,08	65	14,0	17,0	053094
880 Lg-E 12	11,17	65	14,9	17,0	053100
880 Lg-E 14	12,90	65	16,5	18,5	053117



- With hinge joint
- For working in areas with restricted access
- drive 10 = 3/8"
- For outside TORX® screws
- Handy and milled
- For manual operation
- Chrome-Vanadium
- Surface chrome-plated, polished

HAZET No.	l mm	d ₁ mm	d ₂ mm	EAN-No. 4000896+	
880 G-E 8	7,52	43	19	19	040599
880 G-E 10	9,42	44	19	19	040537
880 G-E 12	11,17	46	19	19	040551
880 G-E 14	12,90	48	19	19	040575

TORX® Socket Set



4 TORX® Sockets with hinge joint

contents:
880 G-E 8 E 10 E 12 E 14

HAZET No.	EAN-No. 4000896+
880 G-E/4	040520

TORX® Sockets



- drive 10 = 3/8"
- For outside TORX® screws
- Handy and milled
- For manual operation
- Chrome-Vanadium
- Surface chrome-plated, polished

HAZET No.	l mm	d ₁ mm	d ₂ mm	EAN-No. 4000896+	
880-E 5	4,75	28	7,0	17,0	039258
880-E 6	5,74	28	8,0	17,0	039272
880-E 7	6,22	28	9,0	17,0	039296
880-E 8	7,52	28	10,5	17,0	039319
880-E 10	9,42	28	13,0	17,0	039159
880-E 11	10,08	28	14,0	17,0	039180
880-E 12	11,17	28	14,9	17,0	039197
880-E 14	12,90	28	16,5	18,5	039227

6-Point Spark Plug Sockets



- For spark plug changing
- Long style
- drive 10 = 3/8"
- With permanent magnet
- For manual operation
- Chrome-Vanadium
- Surface chrome-plated, polished

880 A Mg T e.g. for BMW 12-cyl. engines, M 70, 750i, 850i

HAZET No.	s mm	s" mm	l mm	d ₁ mm	EAN-No. 4000896+
880 Mg T	20,8	13/16	64	27,4	040872
880 A Mg T	16,0	5/8	64	21,7	040247



- For spark plug changing
- **With fixing clamp**
- Fixing clamp reduces damages to insulators
- drive 10 = 3/8"
- For manual operation
- Chrome-Vanadium
- Surface chrome-plated, polished

HAZET No.	s mm	s" mm	l mm	EAN-No. 4000896+
880 KF	20,8	13/16	64	040674
880 A KF	16,0	5/8	64	040131



Fixing clamp for 880 KF, 900 KF

880 KF-01	050123
ditto for 880 A KF, 900 A KF	
880 A KF-01	050130

INFORMATION fixing clamp

- Stainless and insensitive to heat
- Largest possible clearance of insulator – therefore no damaging
- 6 spring elements – firm hold of the plugs
- Absorbing of transverse motion
- Smooth socket surface avoids abrasion

6-Point Spark Plug Sockets



- For spark plug changing on motorcycles e.g. HONDA, YAMAHA, SUZUKI, KAWASAKI, etc.
- With permanent magnet
- □ drive 10 = 3/8"
- With outside hexagon 17 mm
- Chrome-Vanadium
- Surface chrome-plated, polished

HAZET No.	S mm	l mm	d ₁ mm	d ₂ mm	EAN-No. 4000896+
880 Mg T-18	18,0	62	23,5	22,8	040889



- For spark plug changing
- With permanent magnet
- □ drive 10 = 3/8"
- With outside guide collar 23.6 mm for deeply located spark plugs
- Chrome-Vanadium
- Surface chrome-plated, polished

HAZET No.	S mm	S"	l mm	d ₁ mm	EAN-No. 4000896+
880 A Mg T-1	16,0	5/8	64	21,9	040254



- For spark plug changing on motorcycles e.g. for BMW-motorcycles K-models and BMW passenger cars (motor sport M3, M5)
- With permanent magnet
- □ drive 10 = 3/8"
- Without outside guide collar
- Chrome-Vanadium
- Surface chrome-plated, polished

HAZET No.	S mm	S"	l mm	d ₁ mm	EAN-No. 4000896+
880 A Mg T-3	17,5	11/16	64	22,6	040278

6-Point Spark Plug Socket Set

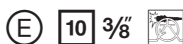

- In plastic box
 - With PUR foam insert – all tools are snugly embedded
 - 4 parts
- contents:
880 KF 880 A KF 880 Mg T-18 880 A Mg T-3

HAZET No.	EAN-No. 4000896+
880 Mg T/4	040902

Screwdriver Sockets



- □ drive 10 = 3/8"
- For inside hexagon screws
- Handy and milled
- For manual operation
- Blades made of special steel
- DIN 7422

s 3 - 9 - 12: not according to DIN
+ = with offset blade

HAZET No.	l ₁ mm	l ₂ mm	d mm	EAN-No. 4000896+
8801- 3 +	23,5	50	17,0	039364
8801- 4 +	28,5	55	17,0	039371
8801- 5 +	33,5	60	17,0	039388
8801- 6	38,5	65	17,0	039395
8801- 7 +	43,5	70	19,0	039401
8801- 8	48,5	75	19,0	039425
8801- 9 +	52,5	80	19,0	039432
8801-10	57,5	85	19,0	039340
8801-12	62,5	90	19,0	039357

- American sizes
 - □ drive 10 = 3/8"
 - For inside hexagon screws
 - Handy and milled
 - For manual operation
 - Blades made of special steel
- + = with offset blade

HAZET No.	l ₁ mm	l ₂ mm	d mm	EAN-No. 4000896+
8801 A-1/8 +	23,5	50	17,0	039487
8801 A-5/32 +	28,5	55	17,0	039524
8801 A-3/16 +	33,5	60	17,0	039494
8801 A-7/32 +	38,5	65	17,0	039531
8801 A-1/4 +	43,5	70	19,0	039470
8801 A-5/16	48,5	75	19,0	039517
8801 A-3/8 +	52,5	80	19,0	039500



- □ drive 10 = 3/8"
- For inside hexagon screws
- Handy and milled
- For manual operation
- Blades made of special steel

HAZET No.	l ₁ mm	l ₂ mm	d mm	S mm	EAN-No. 4000896+
8801 K- 3	17	43,5	17	3	053582
8801 K- 4	17	43,5	17	4	053599
8801 K- 5	17	43,5	17	5	053605
8801 K- 6	17	43,5	17	6	053612
8801 K- 7	17	43,5	19	7	053629
8801 K- 8	17	43,5	19	8	053636
8801 K- 9	17	44,5	19	9	053643
8801 K-10	17	44,5	19	10	053650



- With ball hex
- □ drive 10 = 3/8"
- For inside hexagon screws
- Handy and milled
- For manual operation
- Blades made of special steel

Screwdriver Sockets

HAZET No.	l ₁ mm	l ₂ mm	d mm	S mm	EAN-No. 4000896+
8801 KK- 5	89,5	116	17,0	5	039586
8801 KK- 6	89,5	116	17,0	6	039593
8801 KK- 7	89,5	116	19,0	7	039609
8801 KK- 8	89,5	116	19,0	8	039616
8801 KK-10	88,5	116	19,0	10	039579

TORX® Screwdriver Sockets



- □ drive 10 = 3/8"
- For inside TORX® screws
- Handy and milled
- For manual operation
- Blades made of special steel

HAZET No.	mm	l ₁ mm	l ₂ mm	d mm	EAN-No. 4000896+
8802-T 15	3,27	17	43,5	19	039647
8802-T 20	3,86	17	43,5	19	039654
8802-T 25	4,43	17	43,5	19	039661
8802-T 27	4,99	17	43,5	19	039678
8802-T 30	5,52	17	43,5	19	039685
8802-T 40	6,65	17	43,5	19	039708
8802-T 45	7,82	17	43,5	19	039722
8802-T 50	8,83	17	44,5	19	039753

Screwdriver Sockets

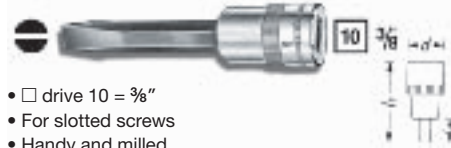

- □ drive 10 = 3/8"
- For slotted screws
- Handy and milled
- For manual operation
- Blades made of special steel

HAZET No.	l ₁ mm	l ₂ mm	d mm	EAN-No. 4000896+
8803-1 x 5,5	48,5	75	17,0	039814
8803-1,2 x 8	53,5	80	19,0	039791
8803-1,6 x 10	62,5	90	19,0	039807



- □ drive 10 = 3/8"
- For Phillips-Recess screws
- Handy and milled
- For manual operation
- Blades made of special steel
- Tips DIN ISO 8764-1

HAZET No.	l ₁ mm	l ₂ mm	d mm	EAN-No. 4000896+
8806-PH 1	23,5	50	17,0	039845
8806-PH 2	23,5	50	17,0	039852
8806-PH 3	28,5	55	19,0	039869
8806-PH 4	32,5	60	19,0	039876



- □ drive 10 = 3/8"
- For inside screws with internal serration XZN
- Handy and milled
- For manual operation
- Blades made of special steel

HAZET No.	M	l ₁ mm	l ₂ mm	d mm	EAN-No. 4000896+
8808- 5	5	13,5	40	19	039982
8808- 6	6	13,5	40	19	039999
8808- 8	8	14,5	41	19	040001
8808-10	10	14,5	42	19	039975

Screwdriver Sockets



- drive 10 = 3/8"
- For inside screws with internal serration XZN
- Handy and milled
- For manual operation
- Blades made of special steel

HAZET No.	M	l ₁ mm	l ₂ mm	d mm	EAN-No. 4000896+
8808 Lg- 8	8	61,5	88	19	040025
8808 Lg-10	10	61,5	89	19	040018

Speeder



- drive 10 = 3/8"
- Chrome-Vanadium
- Surface chrome-plated
- DIN 3122, ISO 3315

HAZET No.	l mm	EAN-No. 4000896+
8811	420	042005

Spin Type Speeder



- drive 10 = 3/8"
- TRInamicULTRA handle
- Best possible connection of hand and handle due to "Haptik" elements
- Antislipping even with greasy hands
- Chrome-Vanadium
- Surface mat chrome-plated

HAZET No.	l mm	EAN-No. 4000896+
8812 U	137	067688

Flexible Handle



- drive 10 = 3/8"
- Chrome-Vanadium
- Surface chrome-plated
- DIN 3122, ISO 3315

HAZET No.	l mm	EAN-No. 4000896+
8814	250	042036

Sliding T-Handle



- drive 10 = 3/8"
- Chrome-Vanadium
- Surface chrome-plated, polished
- DIN 3122, ISO 3315

HAZET No.	l mm	EAN-No. 4000896+
8815	198	042067

Fine-Tooth Reversible Ratchet

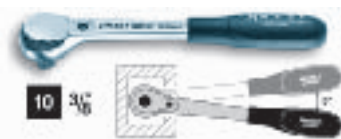

- drive 10 = 3/8"
- With 72 teeth, **actuation angle 5°**, allow operation in areas with restricted access
- With quick-release press-button
- Chrome-Vanadium
- Surface chrome-plated
- DIN 3122, ISO 3315

HAZET No.	l mm	EAN-No. 4000896+
8816 F	199	042074

Reversible Ratchets



- Long style
- **With hinge joint** for working in areas with restricted access
- drive 10 = 3/8"
- Ratchet wheel 30 teeth
- Chrome-Vanadium
- Surface chrome-plated, polished

HAZET No.	l mm	EAN-No. 4000896+
8816 G	276	042104



- Short style
- **With hinge joint**
- drive 10 = 3/8"
- Ratchet wheel 30 teeth
- Chrome-Vanadium
- Surface chrome-plated, polished

HAZET No.	l mm	EAN-No. 4000896+
8816 GK	218	042142

»Komposit« Reversible Ratchet



- drive 10 = 3/8"
- With locking device and quick-release press-button by pressing the button, attached tools are easily released – with just one hand
- Change-over switch on handle enables one-hand operation
- Components are easily replaceable due to "Komposit" construction
- Shock resistant plastic body
- Ergonomic design
- Smooth-running ratchet wheel (30 teeth)
- Safe locking of the sockets
- Chrome-Vanadium
- Cover plates made of chrome-plated steel
- DIN 3122, ISO 3315
- DBP

HAZET No.	l mm	EAN-No. 4000896+
8816 N	200	042173

Reversible Ratchets



- drive 10 = 3/8"
- Ratchet wheel 30 teeth
- Chrome-Vanadium
- Surface chrome-plated, polished
- DIN 3122, ISO 3315

HAZET No.	l mm	EAN-No. 4000896+
8816 P	199	042203



- drive 10 = 3/8"
- With locking device and quick-release press-button by pressing the button, attached tools are easily released – with just one hand
- Ratchet wheel 30 teeth
- Safe locking of the sockets
- Chrome-Vanadium
- Surface chrome-plated, heads polished

HAZET No.	l mm	EAN-No. 4000896+
8816 S	199	042241

Spare Parts for Reversible Ratchets



HAZET No.	EAN-No. 4000896+
8816 P/5	042227

Repair Set for shift lever
consisting of: shift lever, screws, ball, compression spring for 8816 G, 8816 GK, 8816 P, 8816 S, 8816 ST 2264-1, 6110 CT, 6110-1 CT, 6111-1 CT, 6114-1 CT, 6115-1 CT 6402-1, 6402-1 S, 6408-1

8816 P/5	042227
----------	--------

Repair Set for ratchet wheel 10 = 3/8" ■
consisting of: ratchet wheel, pawl, shift lever, screws, ball, compression spring for 8816 G, 8816 GK, 8816 P, 8816 ST, 6110 CT, 6110-1 CT, 6111-1 CT, 6114-1 CT, 6115-1 CT, 6402-1

8816 P/7 N	042234
------------	--------

Repair Set for ratchet wheel 10 = 3/8" ■
consisting of: ratchet wheel with quick-release press-button, pawl, cap screws, 1 holding down bolt each (small and large), for 8816 N

8816 N/6	042197
----------	--------

Repair Set for ratchet wheel 10 = 3/8" ■
consisting of: ratchet wheel, pawl, shift lever, screws, ball, compression spring for 8816 S, 6402-1 S

8816 S/7	048465
----------	--------

Universal Joint

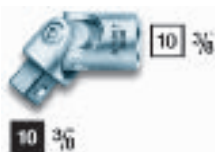

- drive 10 = 3/8"
- Chrome-Vanadium
- Surface chrome-plated, heads polished
- DIN 3123, ISO 3316

HAZET No.	l mm	EAN-No. 4000896+
8820	46,5	042296

Extensions



- drive 10 = 3/8"
- Chrome-Vanadium
- Surface chrome-plated, heads polished
- DIN 3123, ISO 3316

HAZET No.	l mm	EAN-No. 4000896+
8821- 1	36	042302
8821- 3	74	042357
8821- 5	126	042364
8821- 6	150	042371
8821- 8	202	042388
8821-10	254	042319
8821-12	304	042326
8821-20	508	042333
8821-28	711	042340

Wobble Extensions



- drive 10 = 3/8"
- With ball shaped, conical outside square drive, allows 8° angular movement to every side
- Wobble Extension can also be used as rigid connection by attaching a Socket until the limit stop is reached
- Flexible shaft enables getting over obstacles and borders in areas with restricted access
- Chrome-Vanadium
- Surface chrome-plated, polished

HAZET No.	l mm	EAN-No. 4000896+
8822- 1	36	042418
8822- 3	74	042432
8822-10	254	042425

Locking Adapter



- drive 10 = 3/8"
- Eliminates the risk of socket loss in areas with restricted access
- Easy and quick releasing of tool by pulling back the knurled ring
- Chrome-Vanadium
- Surface chrome-plated, polished

HAZET No.	l mm	EAN-No. 4000896+
8823	52,7	053032

Flexible Extension



- drive 10 = 3/8"
- Flexible shaft enables getting over obstacles and borders and fast working even in areas with restricted access
- Chrome-Vanadium

HAZET No.	l mm	EAN-No. 4000896+
8830	210	042487

Adapters



- drive 10 = 3/8"
- Chrome-Vanadium
- Surface chrome-plated
- DIN 3123, ISO 3316

HAZET No.	l mm	EAN-No. 4000896+
■ drive 12.5 = 1/2"		
8858-1	36	042562
■ drive 6.3 = 1/4"		
8858-2	26	042579

Socket Sets (6-Point)



- drive 10 = 3/8"
- In plastic box
- With PUR foam insert – all tools are snugly embedded
- 16 parts

contents:
880-8 10 11 12 13 14 15 17 19 21 22
8815 8816 P 8820 8821-5 10

HAZET No.	EAN-No. 4000896+
880 N-1	040926



- drive 10 = 3/8"
- In plastic box with integrated handle
- With PUR foam insert – all tools are snugly embedded
- 22 parts

contents:
880-6 7 8 9 10 11 12 13 14 15 16
17 18 19 20 21 22
8815 8816 P 8820 8821-3 6

HAZET No.	EAN-No. 4000896+
880-2	039036

Socket Sets (6-Point)

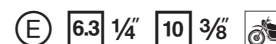

- Especially for motorcycles, motorboats, etc.
- drive 6.3 = 1/4"
- drive 10 = 3/8"
- In plastic box with integrated handle
- With PUR foam insert – all tools are snugly embedded
- 46 parts

contents:
850-4 4,5 5 5,5 6 7
8 9 10 11 12 13
863 P 866 U
867-4 869
880-10 11 12 13 14 15
16 17 18 19 21 22
8816 P 8820 8821-6
2204-3 4 5 6 8
2208-4 6 8 9
2215-PH1 PH2
2216-PZ1 PZ2
2250-1 2

HAZET No.	EAN-No. 4000896+
882	042289



- Especially suitable for working in modern cars where the utilisation of different screw profiles is necessary
- drive 6.3 = 1/4"
- drive 10 = 3/8"
- – 6-Point Sockets
– TORX® Sockets
– Screwdriver Sockets for inside hexagon and inside TORX® screws
- In plastic box with integrated handle
- With PUR foam insert – all tools are snugly embedded
- 46 parts

contents:
850-6 7 8 9 10 13
850-E6 E7 E8 E10
863 P 866 U
867-4 869
880-11 12 13 14 15 16
17 18 19 21 22
880-E11 E12 E14
8816 P 8820 8821-6
2204-4 5 6 8
2223-T 10 T15 T20 T25
T27 T30 T40
2224-T45 T50
2250-1 3

HAZET No.	EAN-No. 4000896+
882-1	100361

Socket Sets (6-Point)



(E) 10 3/8"

- With Spark Plug Sockets
- □ drive 10 = 3/8"
- In plastic box
- With PUR foam insert – all tools are snugly embedded
- 21 parts

contents:
880-6 7 8 9 10 11 12 13
14 15 16 17 18 19 21 22
880 AKF 880 KF
8816 P 8820 8821-5

HAZET No. EAN-No. 4000896+

884 N-1 042531



(E) 10 3/8"

- With Screwdriver Sockets
- □ drive 10 = 3/8"
- In plastic box with integrated handle
- With PUR foam insert – all tools are snugly embedded
- 32 parts

contents:
880-6 7 8 9 10 11 12 13
14 15 16 17 18 19 21 22
8801-4 5 6 8
8803-1 x 5,5 1,2 x 8 1,6 x 10
8806-PH1 PH2 PH3
8815 8816 P 8820
8821-3 5 10

HAZET No. EAN-No. 4000896+

885 N 042593



(E) 10 3/8"

- American sizes
- With Spark Plug Sockets
- □ drive 10 = 3/8"
- In plastic box
- With PUR foam insert – all tools are snugly embedded
- 14 parts

contents:
880 A-1/4 5/16 3/8 7/16 1/2 9/16 5/8 11/16 3/4
880 KF 880 AKF 8816 P 8820 8821-5

HAZET No. EAN-No. 4000896+

884 A N-1 042494

Socket Sets (12-Point)



(E) 10 3/8"

- □ drive 10 = 3/8"
- In plastic box
- With PUR foam insert – all tools are snugly embedded
- 16 parts

contents:
880 Z-10 11 12 13 14
15 17 19 21 22
880-8 8815
8816 P 8820 8821-5 10

HAZET No. EAN-No. 4000896+

880 Z N-1 041992



(E) 10 3/8"

- American sizes
- With Spark Plug Sockets
- □ drive 10 = 3/8"
- In black plastic box
- With PUR foam insert – all tools are snugly embedded
- 17 parts

contents:
880 AZ-1/4 5/16 3/8 7/16 1/2 9/16
5/8 11/16 3/4 13/16 7/8 15/16
880 KF 880 AKF
8816 P 8820 8821-5

HAZET No. EAN-No. 4000896+

884 AZ N-1 042517

Socket Sets (6-Point)



(E) 10 3/8"

- With Combination Wrenches
- □ drive 10 = 3/8"
- In plastic box with integrated handle
- With PUR foam insert – all tools are snugly embedded
- 25 parts

contents:
603-8 10 11 12 13 14 15 17 19 22
880-8 10 11 12 13 14 15 17 19 22
8815 8816 P 8820 8821-3 5

HAZET No. EAN-No. 4000896+

889 N 042661

Socket Sets (6-Point)

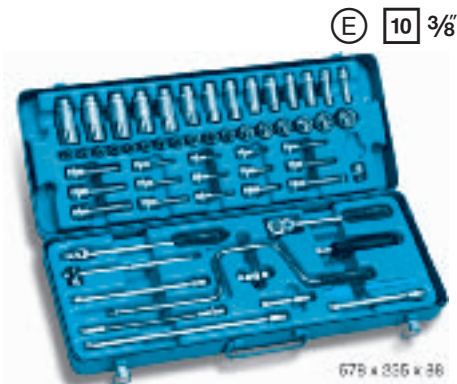

(E) 10 3/8"

- □ drive 10 = 3/8"
- In sheet metal box with plastic insert
- 58 parts

contents:
880-6 7 8 9 10 11 12 13 14
15 16 17 18 19 20 21 22
880 Lg-9 10 11 12 13 14 15
16 17 18 19 20 21 22
8801-3 4 5 6 7 8 9 10 12
8803-1 x 5,5 1,2 x 8 1,6 x 10
8806-PH2 PH3 PH4
8811 8812
8814 8815
8816 P 8820
8821-3 6 8 12
8830 8858-2

HAZET No. EAN-No. 4000896+

888 N 042623

Socket Sets (12-Point)



(E) 10 3/8"

- American sizes
- □ drive 10 = 3/8"
- In sheet metal box with plastic insert
- 17 parts

contents:
880 AZ-3/8 7/16 1/2 9/16 19/32 5/8
11/16 3/4 25/32 13/16 7/8 15/16
8815 8816 S 8820
8821-5 10

HAZET No. EAN-No. 4000896+

880 AZ N-1 084784



(E) 10 3/8"

- American sizes
- □ drive 10 = 3/8"
- In sheet metal box with plastic insert

Socket Sets (12-Point)

◀ (E) 10 3/8

• 19 parts
 contents:
 880 AZ-3/8 7/16 1/2 9/16 5/8
 11/16 3/4 13/16 7/8 15/16
 880 A-1/4 5/16
 880 AKF
 8811 8814 8815 8816 P 8820
 8821-3 6 8 12

HAZET No.	EAN-No. 4000896+
881 AZ	042265

(E) 10 3/8



- American sizes
- With Screwdriver Sockets
- With blank moulds to adapt additional tools
- □ drive 10 = 3/8"
- In sheet metal box with plastic insert
- 49 parts

contents:
 880 AZ-3/8 7/16 1/2 9/16 19/32 5/8
 11/16 3/4 29/32 13/16 7/8 15/16
 880 A Lg-3/8 7/16 1/2 9/16 19/32
 5/8 11/16 3/4 13/16 7/8

880 Lg-20,8 (19/16)
 8801 A-1/8 5/32 3/16 7/32 1/4 5/16 3/8
 8803-1 x 5,5 1,2 x 8 1,6 x 10
 8806-PH2 PH3 PH4
 8811 8812 8814
 8815 8816 P 8820
 8821-3 6 8 12
 8830 8858-2

HAZET No.	EAN-No. 4000896+
888 A ZN	042616

(E) 10 3/8



- With Screwdriver Sockets
- □ drive 10 = 3/8"
- In sheet metal box with plastic insert
- 58 parts

contents:
 880-6 7 8
 880Z-9 10 11 12 13 14 15
 16 17 18 19 20 21 22
 880TZ-9 10 11 12 13 14 15
 16 17 18 19 20 21 22
 8801-3 4 5 6 7 8 9 10 12
 8803-1 x 5,5 1,2 x 8 1,6 x 10
 8806-PH2 PH3 PH4

Socket Sets (12-Point)

◀ (E) 10 3/8

contents:
 8811 8812 8814 8815
 8816 P 8820
 8821-3 6 8 12
 8830 8858-2

HAZET No.	EAN-No. 4000896+
888 ZN	042654

Socket Sets

(E) 10 3/8

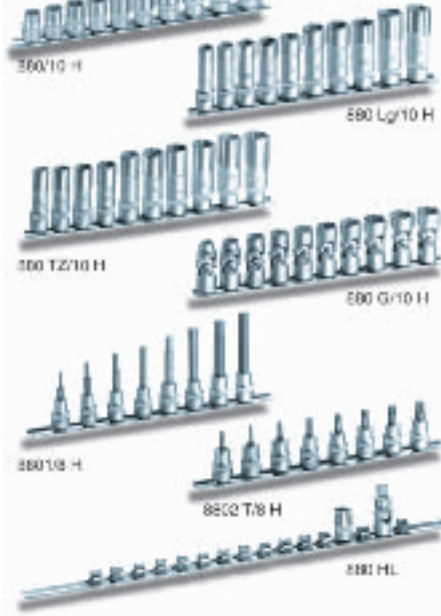

- □ drive 10 = 3/8"
- Easy installation: with 2 bore holes for e.g. wall fixation
- With clips suitable for the corresponding socket drive
- Clear arrangement on rail keeps sockets always ready to hand
- Made of metal

HAZET No.	l mm	EAN-No. 4000896+
-----------	------	------------------

10 6-Point Sockets

contents:		
HAZET No.	l mm	EAN-No. 4000896+
880/10 H	240	051441

10 6-Point Sockets, long style

contents:		
HAZET No.	l mm	EAN-No. 4000896+
880 Lg/10 H	240	040865

10 12-Point Sockets

contents:		
HAZET No.	l mm	EAN-No. 4000896+
880 TZ/10 H	240	041831

10 6-Point Sockets with hinge joint

contents:		
HAZET No.	l mm	EAN-No. 4000896+
880 G/10 H	240	040612

8 Screwdriver Sockets for inside hexagon screws

contents:		
HAZET No.	l mm	EAN-No. 4000896+
8801/8 H	240	039463

8 Screwdriver Sockets for inside TORX® screws

contents:		
HAZET No.	l mm	EAN-No. 4000896+
8802 T/8 H	240	039784

empty with 16 clips for sockets suitable for Sockets of 880 series

880 HL	430	040650
--------	-----	--------

6-Point Sockets

(E) 12.5 1/2



- □ drive 12.5 = 1/2"
- With Traction profile
- Handy and milled
- For manual operation
- Chrome-Vanadium
- Surface chrome-plated, polished
- DIN 3124, ISO 2725

* = not according to DIN

HAZET No.	l mm	d ₁ mm	d ₂ mm	t mm	EAN-No. 4000896+
900-8*	38,0	12,0	22,0	7,5	042968
900-9*	38,0	13,5	22,0	8,5	042975
900-10	38,0	14,9	22,0	10,5	042715
900-11	38,0	16,4	22,0	10,5	042722
900-12	38,0	17,5	22,0	11,0	042739
900-13	38,0	18,8	22,0	11,0	042746
900-14	38,0	20,3	22,0	11,5	042753
900-15	38,0	21,5	23,2	11,5	042760
900-16	38,0	22,7	23,6	12,5	042777
900-17	38,0	24,1	22,0	12,5	042784
900-18	38,0	25,4	22,4	14,0	042791
900-19	38,0	26,6	23,0	14,0	042807
900-20	38,0	27,8	24,0	14,0	042821
900-21	38,0	29,0	25,0	14,0	042838
900-22	41,5	30,4	26,0	17,5	042845
900-23	41,5	31,4	26,0	17,5	042869
900-24	44,0	32,6	26,0	20,0	042876
900-25	44,0	33,9	26,0	20,0	042883
900-26	44,0	35,1	24,0	20,0	042890
900-27	46,0	36,2	25,0	21,0	042906
900-28	47,0	37,5	26,0	22,0	042913
900-29*	50,0	38,7	27,0	25,0	042920
900-30	50,0	40,1	28,0	25,0	042937
900-32	50,0	42,3	28,0	24,0	042944
900-34*	52,0	46,0	28,0	22,0	042951

- American sizes
- □ drive 12.5 = 1/2"
- With Traction profile
- Handy and milled
- For manual operation
- Chrome-Vanadium
- Surface chrome-plated, polished

HAZET No.	l mm	d ₁ mm	d ₂ mm	t mm	EAN-No. 4000896+
900 A-3/8	38,0	14,5	22,0	10,5	043354
900 A-7/16	38,0	16,4	22,0	10,5	043378
900 A-1/2	38,0	18,3	22,0	11,0	043309
900 A-9/16	38,0	20,5	22,5	11,5	043392
900 A-5/8	38,0	22,7	23,6	12,5	043361
900 A-11/16	38,0	24,6	22,0	12,0	043316
900 A-3/4	38,0	26,8	23,0	14,0	043347
900 A-13/16	38,0	28,6	25,0	14,0	043323
900 A-7/8	41,5	30,4	26,0	17,5	043385
900 A-15/16	44,0	32,6	26,0	20,0	043330
900 A-1	44,0	34,6	24,5	20,0	043255
900 A-1 1/16	46,0	36,3	25,0	21,0	043262
900 A-1 1/8	47,0	38,2	26,5	22,0	043286
900 A-1 3/16	50,0	40,0	28,0	25,0	043293
900 A-1 1/4	50,0	42,3	28,0	24,0	043279



6-Point Sockets



- Long style
- drive 12.5 = 1/2"
- **With Traction profile**
- Handy and milled
- For manual operation
- Chrome-Vanadium
- Surface chrome-plated, polished
- DIN 3124, ISO 2725-1

* = not according to DIN
+ = with rubber ply for spark plugs

HAZET No.	l mm	d ₁ mm	d ₂ mm	t mm	EAN-No. 4000896+
900 Lg-10 *	85	14,9	22,0	10,0	053438
900 Lg-11 *	85	16,4	22,0	11,5	053421
900 Lg-12 *	85	17,5	22,0	12,3	043873
900 Lg-13	85	18,8	22,0	13,3	043880
900 Lg-14	85	19,9	22,5	15,0	043897
900 Lg-15	85	21,5	23,2	15,0	043903
900 Lg-16	85	22,7	23,6	15,0	043910
900 Lg-17	85	24,1	23,6	15,0	043927
900 Lg-18	85	24,6	23,6	15,0	043934
900 Lg-19	85	28,5	26,0	18,0	043941
900 Lg-20,8 +	85	28,5	24,5	18,0	043958
900 Lg-21	85	28,6	24,5	18,0	043965
900 Lg-22	85	30,4	25,0	21,0	043972
900 Lg-24	85	32,6	27,5	24,0	043989
900 Lg-26	85	35,1	29,5	24,0	043996
900 Lg-27	85	36,3	30,0	27,0	044009
900 Lg-30	85	40,1	33,0	30,0	044016
900 Lg-32	85	42,5	35,0	34,2	049660

- American sizes
 - Long style
 - drive 12.5 = 1/2"
 - **With Traction profile**
 - Handy and milled
 - For manual operation
 - Chrome-Vanadium
 - Surface chrome-plated, polished
- + = with rubber ply for spark plugs

HAZET No.	l mm	d ₁ mm	d ₂ mm	t mm	EAN-No. 4000896+
900 A Lg-1/2	85	18,3	22,0	12	043422
900 A Lg-9/16	85	20,5	22,5	15	043484
900 A Lg-3/8	85	22,7	23,6	15	043460
900 A Lg-11/16	85	24,6	23,6	15	043439
900 A Lg-3/4	85	26,8	26,0	18	043453
900 A Lg-13/16 +	85	28,5	24,5	18	043958
900 A Lg-7/8	85	30,4	25,0	21	043477
900 A Lg-15/16	85	32,6	27,5	24	043446
900 A Lg-1	85	34,6	29,5	24	043415

12-Point Sockets



- drive 12.5 = 1/2"
- **With Traction profile**
- Handy and milled
- For manual operation
- Chrome-Vanadium
- Surface chrome-plated, polished
- DIN 3124, ISO 2725-1

* = not according to DIN

HAZET No.	l mm	d ₁ mm	d ₂ mm	t mm	EAN-No. 4000896+
900 Z- 8 *	38,0	12,0	22,0	7,5	045686
900 Z- 9 *	38,0	13,5	22,0	8,5	045693
900 Z-10	38,0	14,9	22,0	10,5	045457
900 Z-11	38,0	16,4	22,0	10,5	045464

12-Point Sockets



* = not according to DIN

HAZET No.	l mm	d ₁ mm	d ₂ mm	t mm	EAN-No. 4000896+
900 Z-12	38,0	17,5	22,0	11,0	045471
900 Z-13	38,0	18,8	22,0	11,0	045488
900 Z-14	38,0	20,3	22,5	11,5	045495
900 Z-15	38,0	21,5	23,2	11,5	045501
900 Z-16	38,0	22,7	23,6	12,5	045518
900 Z-17	38,0	24,1	22,0	12,5	045525
900 Z-18	38,0	25,4	22,4	14,0	045532
900 Z-19	38,0	26,6	23,0	14,0	045549
900 Z-20	38,0	27,8	24,0	14,0	045556
900 Z-21	38,0	29,0	25,0	14,0	045563
900 Z-22	41,5	30,4	25,0	17,5	045570
900 Z-23	41,5	31,4	26,0	17,5	045587
900 Z-24	44,0	32,6	26,0	20,0	045594
900 Z-25	44,0	33,9	26,5	20,0	045600
900 Z-26	44,0	35,1	24,0	20,0	045617
900 Z-27	46,0	36,2	25,0	21,0	045624
900 Z-28	47,0	37,5	26,0	22,0	045631
900 Z-29 *	50,0	38,7	27,0	25,0	045648
900 Z-30	50,0	40,1	28,0	25,0	045655
900 Z-32	50,0	42,3	28,0	24,0	045662
900 Z-33 *	50,0	43,6	28,0	24,0	045679



- American sizes
- drive 12.5 = 1/2"
- Handy and milled
- For manual operation
- Chrome-Vanadium
- Surface chrome-plated, polished

HAZET No.	l mm	d ₁ mm	d ₂ mm	t mm	EAN-No. 4000896+
900 AZ-3/8	38,0	14,5	22,0	10,5	043699
900 AZ-7/16	38,0	16,4	22,0	10,5	043729
900 AZ-1/2	38,0	18,3	22,0	11,0	043620
900 AZ-9/16	38,0	20,5	22,5	11,5	043743
900 AZ-19/32	38,0	21,5	23,2	11,5	043668
900 AZ-5/8	38,0	22,7	23,6	12,5	043712
900 AZ-11/16	38,0	24,6	22,0	12,5	043637
900 AZ-3/4	38,0	26,8	23,0	14,0	043682
900 AZ-25/32	38,0	27,8	24,0	14,0	043675
900 AZ-13/16	38,0	28,6	25,0	14,0	043644
900 AZ-7/8	41,5	30,4	26,0	17,5	043736
900 AZ-15/16	44,0	32,6	26,0	20,0	043651
900 AZ-31/32	44,0	33,4	24,6	20,0	043705
900 AZ-1	44,0	34,6	24,8	20,0	043576
900 AZ-1 1/16	46,0	36,3	25,0	21,0	043583
900 AZ-1 1/8	47,0	38,2	26,5	22,0	043606
900 AZ-1 3/16	50,0	40,1	28,0	25,0	043613
900 AZ-1 1/4	50,0	42,3	28,0	24,0	043590



- Long style
- drive 12.5 = 1/2"
- **With Traction profile**
- Handy and milled
- For manual operation
- Chrome-Vanadium
- Surface chrome-plated, polished
- DIN 3124, ISO 2725-1

* = not according to DIN

+ = with rubber ply for spark plugs

HAZET No.	l mm	d ₁ mm	d ₂ mm	t mm	EAN-No. 4000896+
900 TZ-10 *	85	14,9	22,0	10,0	053452
900 TZ-11 *	85	16,4	22,0	10,0	053445
900 TZ-12 *	85	17,5	22,0	11,0	045242
900 TZ-13	85	18,8	22,0	12,0	045259
900 TZ-14	85	19,9	22,5	15,0	045266
900 TZ-15	85	21,5	23,2	15,0	045273

12-Point Sockets

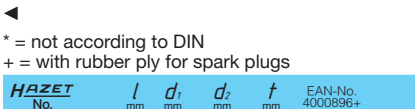

* = not according to DIN
+ = with rubber ply for spark plugs

HAZET No.	l mm	d ₁ mm	d ₂ mm	t mm	EAN-No. 4000896+
900 TZ-16	85	22,7	23,6	15,0	045280
900 TZ-17	85	24,1	23,6	15,0	045297
900 TZ-18	85	24,6	23,6	15,0	045310
900 TZ-19	85	26,8	26,0	18,0	045334
900 TZ-20,8 +	85	28,5	24,5	18,0	045341
900 TZ-21	85	28,6	24,5	18,0	045358
900 TZ-22	85	30,4	25,0	21,0	045365
900 TZ-24	85	32,6	27,5	24,0	045389
900 TZ-27	85	36,3	30,0	27,0	045419
900 TZ-30	85	40,1	33,0	30,0	045426

- Long style
 - American sizes
 - drive 12.5 = 1/2"
 - **With Traction profile**
 - Handy and milled
 - For manual operation
 - Chrome-Vanadium
 - Surface chrome-plated, polished
- + = with rubber ply for spark plugs

HAZET No.	l mm	d ₁ mm	d ₂ mm	t mm	EAN-No. 4000896+
900 TAZ-1/2	85	18,3	22,0	12,0	045167
900 TAZ-9/16	85	20,5	22,5	15,0	045228
900 TAZ-3/8	85	22,7	23,6	15,0	045204
900 TAZ-11/16	85	24,6	23,6	15,0	045174
900 TAZ-5/8	85	26,8	26,0	18,0	045198
900 TAZ-13/16 +	85	28,5	24,5	18,0	045341
900 TAZ-7/8	85	30,4	25,0	21,0	045211
900 TAZ-15/16	85	32,6	27,5	24,0	045181
900 TAZ-1	85	34,6	29,5	24,0	045150

TORX® Sockets



- drive 12.5 = 1/2"
- For outside TORX® screws
- Handy and milled
- For manual operation
- Chrome-Vanadium
- Surface chrome-plated, polished

HAZET No.	l mm	d ₁ mm	d ₂ mm	t mm	EAN-No. 4000896+
900-E 10	9,42	38,0	13,3	22	042982
900-E 11	10,08	38,0	14,0	22	043002
900-E 12	11,17	38,0	14,9	22	043019
900-E 14	12,90	38,0	16,7	22	043033
900-E 16	14,76	38,0	19,0	22	043057
900-E 18	16,70	38,0	21,0	27	043071
900-E 20	18,45	38,0	23,5	27	043095
900-E 24	22,16	41,2	28,5	27	043118

Spark Plug Sockets (6-Point)



- For spark plug changing
- Long style
- drive 12.5 = 1/2"
- With permanent magnet
- For manual operation
- Chrome-Vanadium
- Surface chrome-plated, polished

HAZET No.	s mm	s "	l mm	d ₁ mm	EAN-No. 4000896+
900 Mg T	20,8	13/16	68	27,4	044023
900 A Mg T	16,0	5/8	71	22,5	043491

Spark Plug Sockets (6-Point)

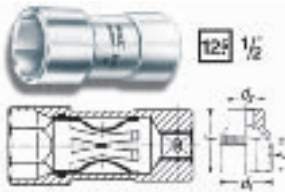

- For spark plug changing
- **With fixing clamp**
- Fixing clamp reduces damages to insulators
- □ drive 12.5 = 1/2"
- For manual operation
- Chrome-Vanadium
- Surface chrome-plated, polished

HAZET No.	s mm	s" / 16	l mm	d ₁ mm	EAN-No. 4000896+
900 KF	20,8	1 3/16	71	27,4	043859
900 A KF	16,0	5/8	71	22,5	043408



Fixing clamp for 880 KF, 900 KF

880 KF-01	050123
ditto for 880 A KF, 900 A KF	
880 A KF-01	050130



INFORMATION fixing clamp

- Stainless and insensitive to heat
- Largest possible clearance of insulator – therefore no damaging
- 6 spring elements – firm hold of the plugs
- Absorbing of transverse motion
- Smooth socket surface avoids abrasion

Speeder



- ■ drive 12.5 = 1/2"
- Chrome-Vanadium
- Surface chrome-plated
- DIN 3122, ISO 3315

HAZET No.	l mm	EAN-No. 4000896+
911	415	046010

Flexible Handles



- ■ drive 12.5 = 1/2"
- Chrome-Vanadium
- Surface chrome-plated
- DIN 3122, ISO 3315

HAZET No.	l mm	EAN-No. 4000896+
914-15	396	046027
914-18	472	046041

Sliding T-Handle



- ■ drive 12.5 = 1/2"
- Chrome-Vanadium
- Surface chrome-plated, polished
- DIN 3122, ISO 3315

HAZET No.	l mm	EAN-No. 4000896+
915	298	046072

Fine-Tooth Reversible Ratchet



- ■ drive 12.5 = 1/2"
- With 72 teeth, **actuation angle 5°**, enable working in areas with restricted access
- With quick-release press-button
- Chrome-Vanadium
- Surface chrome-plated
- DIN 3122, ISO 3315

HAZET No.	l mm	EAN-No. 4000896+
916 F	260	046140

Reversible Ratchet



- Short style
- **With hinge joint**
- ■ drive 12.5 = 1/2"
- Ratchet wheel 32 teeth
- Chrome-Vanadium
- Surface chrome-plated, polished

HAZET No.	l mm	EAN-No. 4000896+
916 GK	270	046201

»Komposit« Reversible Ratchet



- ■ drive 12.5 = 1/2"
- **With locking device and quick-release press-button** by pressing the button, attached tools are easily released – with just one hand
- Change-over switch on handle enables one-hand operation
- Components are easily replaceable due to "Komposit" construction
- Shock resistant plastic body
- Ergonomic design
- Smooth-running ratchet wheel (32 teeth)
- Safe locking of the sockets
- Chrome-Vanadium
- Cover plates made of chrome-plated steel
- DIN 3122, ISO 3315
- DBP

HAZET No.	l mm	EAN-No. 4000896+
916 N	275	046256

Reversible Ratchets

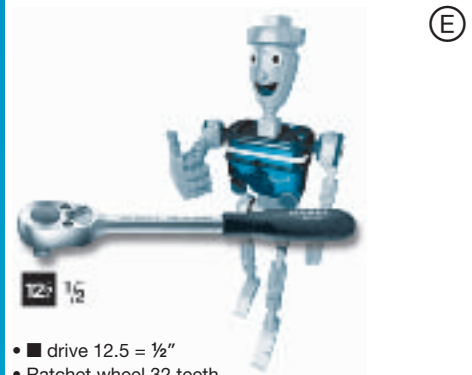

- ■ drive 12.5 = 1/2"
- Ratchet wheel 32 teeth
- Chrome-Vanadium
- Surface chrome-plated, polished
- DIN 3122, ISO 3315

HAZET No.	l mm	EAN-No. 4000896+
916 SP	275	046317



- ■ drive 12.5 = 1/2"
- **With locking device and quick-release press-button** by pressing the button, attached tools are easily released – with just one hand
- Ratchet wheel 32 teeth
- Safe locking of the sockets
- Chrome-Vanadium
- Surface chrome-plated, heads polished

HAZET No.	l mm	EAN-No. 4000896+
916 S	275	046287

Spare Parts for Reversible Ratchets



HAZET No.	EAN-No. 4000896+
-----------	------------------

Repair Set for ratchet wheel 12.5 = 1/2" ■ consisting of: shift lever, 2 screws, ball, compression spring, ratchet wheel and pawl for 916 S, 916 SP, 916 GK

916 S/7	046300
---------	--------

Repair Set for ratchet wheel 12.5 = 1/2" ■ consisting of: shift lever, 2 screws, ball and compression spring for 916 S, 916 SP, 916 GK

916 SP/5	046331
----------	--------

Repair Set for ratchet wheel 12.5 = 1/2" ■ consisting of: shift lever, screws, ball, compression spring, ratchet wheel and pawl for 916 SP, 916 GK

916 SP/7-1	046348
------------	--------

Repair Set for ratchet wheel 12.5 = 1/2" ■ consisting of: ratchet wheel with quick-release press-button, pawl, cap screws, 1 holding down bolt each (small and large), for 916 N

916 N/6	046270
---------	--------

Extensions



- drive 12.5 = 1/2"
- Chrome-Vanadium
- Surface chrome-plated, heads polished
- DIN 3123, ISO 3316

HAZET No.	l mm	EAN-No. 4000896+
917-1	45	046362
917-3	76	046379
917-5	123	046386



- drive 12.5 = 1/2"
- Chrome-Vanadium
- Surface chrome-plated, heads polished
- DIN 3123, ISO 3316

HAZET No.	l mm	EAN-No. 4000896+
918-10	248	046416
918-23	575	046423

Wobble Extensions



- drive 12.5 = 1/2"
- With ball shaped, conical outside square drive **allows 12.5° angular movement to every side**
- Wobble Extension can also be used as rigid connection by attaching a socket until reaching the limit stop
- Flexible shaft allows to get over obstacles and borders in areas with restricted access
- Chrome-Vanadium
- Surface chrome-plated, polished

HAZET No.	l mm	EAN-No. 4000896+
919-1	46	046447
919-5	123	046461
919-10	248	046454

Sets

cardboard packed

HAZET No.	EAN-No. 4000896+
-----------	------------------

3 parts

contents:
919-1 5 10

919/3	046478
-------	--------

5 parts

contents:
871-4
8822-3 10
919-5 10

919/5	046485
-------	--------

Universal Joint



- drive 12.5 = 1/2"
- Chrome-Vanadium
- Surface chrome-plated, heads polished
- DIN 3123, ISO 3316

HAZET No.	l mm	EAN-No. 4000896+
920	70	046515

Locking Extensions



- drive 12.5 = 1/2"
- Eliminates the risk of socket loss in areas with restricted access
- Easy and quick releasing of the attached tool by pulling back the knurled ring
- Chrome-Vanadium
- Surface chrome-plated, polished

HAZET No.	l mm	EAN-No. 4000896+
923	78	053056

Set with 2 parts

contents:
872 923

923/2	-	053063
-------	---	--------

Security System "Safety Lock"



- drive 12.5 = 1/2"
- Release-safe connection of actuation tools
- Especially for screwed connections in areas with restricted access
- Various combinations and applications possible

set with 4 parts
916 N 923-1 5 10

HAZET No.	EAN-No. 4000896+
923/4	061259



Lockable Universal Joint

923-1	061075
-------	--------

Lockable Extension, 123 mm long

923-5	061082
-------	--------

Lockable Extension, 248 mm long

923-10	061099
--------	--------

Adapters



- drive 12.5 = 1/2"
- Chrome-Vanadium
- Surface chrome-plated, heads polished
- DIN 3123, ISO 3316

HAZET No.	l mm	EAN-No. 4000896+
-----------	------	------------------

<input checked="" type="checkbox"/> drive 20 = 3/4"	50	046676
---	----	--------

<input checked="" type="checkbox"/> drive 10 = 3/8"	36	046683
---	----	--------

Adapter Set

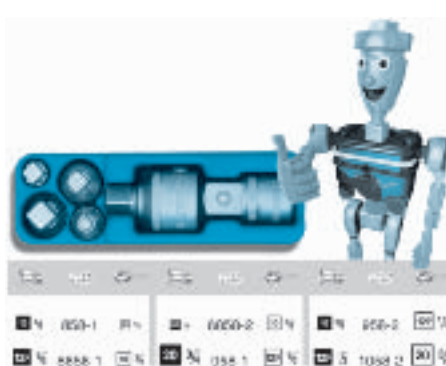

in HAZET plastic drawer insert,
6 parts, 1 Adapter each

contents:
858-1 2
8858-1 2
958-1 2
1058-2

HAZET No.	EAN-No. 4000896+
958/6	073900
Plastic insert, empty	
958/6 PL	073191

Adapter-Extensions



- For working on deeply located screwed connections, e.g. at the gearbox
- drive 12.5 = 1/2"
- drive 10 = 3/8"
- Chrome-Vanadium
- Surface chrome-plated

HAZET No.	l mm	EAN-No. 4000896+
958-23	575	046690
958-28	700	046706

Magnetic Socket Inserts



- Holds firmly the fastener, nuts and screws in the socket
- Inserts made of plastic with integrated magnet
- Powerful retention force
- Universal application in all metric 6-Point and 12-Point Sockets s 10 up to 19 mm
- Easily inserted and removed
- Reusable
- 10 parts, for **metric** sockets s 10 11 12 13 14 15 16 17 18 19 mm

HAZET No.	EAN-No. 4000896+
960 MgT	097661

Screwdriver Sockets



- For slotted screws
- □ drive 12.5 = 1/2"
- Chrome-Vanadium
- Surface chrome-plated

HAZET No.	l ₁ mm	l ₂ mm	d mm	EAN-No. 4000896+
980-2 x 13	21,0	38	22,0	046737
980-3 x 19	20,0	38	23,7	046744



- For inside hexagon screws
- □ drive 12.5 = 1/2"
- Handy and milled
- Blades made of special steel
- DIN 7422

* = not according to DIN

HAZET No.	l ₁ mm	l ₂ mm	l ₃ mm	d mm	EAN-No. 4000896+
985- 4 *	5	38	19	22	046829
985- 5 *	5	38	19	23	046836
985- 6	6	38	20	23	046843
985- 8	8	38	20	23	046850
985-10	10	40	21	25	046775
985-12	12	40	21	25	046782
985-14	14	40	21	25	046799
985-17 *	17	42	23	28	046805
985-19 *	19	42	23	28	046812



- For inside hexagon screws
- □ drive 12.5 = 1/2"
- In sheet metal box with plastic insert
- 12 parts

contents:
985-5 6 8 10 12 14 17 19
915 916SP 917-5 918-10

HAZET No.	EAN-No. 4000896+
985	046768



- For inside hexagon screws
- □ drive 12.5 = 1/2"
- Handy and milled
- Blades made of special steel
- DIN 7422

* = not according to DIN

HAZET No.	l ₁ mm	l ₂ mm	d mm	EAN-No. 4000896+
986- 4 *	22,0	60	23,0	046928
986- 5 *	22,0	60	23,0	046935
986- 6	22,0	60	23,0	046942
986- 7	22,0	60	23,0	046959
986- 8	22,0	60	23,0	046973
986-10	22,0	60	23,0	046874
986-12	22,0	60	24,6	046881
986-14	22,0	60	24,6	046898
986-17 *	20,0	60	28,5	046904
986-19 *	20,0	60	31,5	046911
986-22	20,5	60	28,0	082865

Screwdriver Sockets

- American sizes
- For inside hexagon screws
- □ drive 12.5 = 1/2"
- Handy and milled
- Blades made of special steel

HAZET No.	l ₁ mm	l ₂ mm	d mm	EAN-No. 4000896+
986 A-5/32	14	52	23	047048
986 A-3/16	14	52	23	047017
986 A-1/8	14	52	23	047062
986 A-1/4	14	52	23	047000
986 A-3/16	14	52	23	047031
986 A-3/8	14	52	23	047024
986 A-7/16	14	52	23	047055
986 A-1/2	14	52	23	046997



- Long style
- For inside hexagon screws
- □ drive 12.5 = 1/2"
- Handy and milled
- Blades made of special steel
- DIN 7422

* = not according to DIN

HAZET No.	l ₁ mm	l ₂ mm	d mm	EAN-No. 4000896+
986 Lg- 5 *	142	180	23,0	047109
986 Lg- 6	99	137	23,0	047116
986 Lg- 7	62	100	23,0	047123
986 Lg- 8	42	80	24,6	047130
986 Lg-10	103	141	24,6	047086



- For installing and removing the fuel filter on VW/AUDI diesel engines with engine code AJM since 5/99 (Passat B 5, Golf 4, Bora, AUDI A3 and A4), as well as SEAT and SKODA diesel engines

• Also suitable for fuel filter draining

HAZET No.	l ₁ mm	l ₂ mm	d mm	EAN-No. 4000896+
986 Lg-13	60	100	24,6	089222



- Extra long style
- For inside hexagon screws
- □ drive 12.5 = 1/2"
- Handy and milled
- Blades made of special steel

HAZET No.	l ₁ mm	l ₂ mm	d mm	EAN-No. 4000896+
986 S Lg-6	112	160	23	047147
986 S Lg-8	81	119	23	047154

Screwdriver Sockets



- With ball hex esp. for working in areas with restricted access (e.g. engine compartment)
- For inside hexagon screws
- □ drive 12.5 = 1/2"
- Handy and milled
- Blades made of special steel

HAZET No.	l ₁ mm	l ₂ mm	d mm	EAN-No. 4000896+
986 KK- 5	102	140	23,0	052103
986 KK- 6	102	140	23,0	050666
986 KK- 7	102	140	23,0	052110
986 KK- 8	102	140	23,0	052127
986 KK-10	102	140	23,0	052134
986 KK-12	102	140	24,6	052141

Screwdriver Sets



- Screwdriver Sockets for inside hexagon screws
- □ drive 12.5 = 1/2"
- In sheet metal box with plastic insert
- 9 parts

contents: 6 7 8 10 12 14 17 19

HAZET No.	EAN-No. 4000896+
986/9	051564



- For inside hexagon screws
 - □ drive 12.5 = 1/2"
 - In plastic drawer insert
 - 5 parts
- contents:
986-5 6 7 8 10

HAZET No.	EAN-No. 4000896+
986-P/5	054145

plastic insert, empty	
2191-1 PL	054350



- For inside hexagon screws
 - □ drive 12.5 = 1/2"
 - With ball head
 - In plastic drawer insert
 - 6 parts
- contents:
986 KK-5 6 7 8 10 12

HAZET No.	EAN-No. 4000896+
986 KK-P/6	054091

Plastic insert, empty	
2191-22 PL	054381

Screwdriver Sets



12.5 1/2

- For inside hexagon screws
 - □ drive 12.5 = 1/2"
 - Long style
 - In plastic drawer insert
 - 5 parts
- contents:
986 Lg-5 8 10
986 S Lg-6 8

HAZET No.	EAN-No. 4000896+
986 S Lg-P/5	054039
Plastic insert, empty	
2191-3 PL	054374

Screwdriver Sockets



- For Phillips-Recess screws
- □ drive 12.5 = 1/2"
- Handy and milled
- Blades made of special steel
- Tips according to DIN ISO 8764-1

HAZET No.	M	l ₁ mm	l ₂ mm	d mm	EAN-No. 4000896+
988-PH 2	18	56	23	23	047192
988-PH 3	18	56	23	23	047208
988-PH 4	18	56	23	23	047215



- Short style
- For screws with internal serration XZN
- □ drive 12.5 = 1/2"
- Handy and milled
- Blades made of special steel

HAZET No.	M	l ₁ mm	l ₂ mm	d mm	EAN-No. 4000896+
990-5	5	14	52	23,0	047307
990-6	6	14	52	23,0	047314
990-8	8	15	53	23,0	047321
990-10	10	15	53	23,0	047253
990-12	12	17	55	23,0	047277
990-14	14	20	58	24,6	047284
990-16	16	22	60	24,6	047291

For installing and removing the wheel bearing/hub unit at the rear axle
– AUDI A 3 since 2004
– VW Touran since 2004

See also VW specialty tools on page 108

990-18	• 18	45	85	26,0	108916
--------	------	----	----	------	--------



- Long style
- For screws with internal serration XZN
- □ drive 12.5 = 1/2"
- Handy and milled
- Blades made of special steel

Screwdriver Sockets

- 990 Lg-8 e.g. for cardan shafts on VW-AUDI
- 990 Lg-9 for cylinder head screws on TOYOTA Corolla 1.4 I and YARIS 1.0 I
- 990 Lg-14 for cylinder head screws on VM diesel engines, e.g. CHRYSLER

HAZET No.	M	l ₁ mm	l ₂ mm	d mm	EAN-No. 4000896+
990 Lg-6	6	62	100	23	056248
990 Lg-8	8	62	100	23	047352
990 Lg-9	• 9	62	100	23	103140
990 Lg-10	10	62	100	23	047338
990 Lg-12	12	62	100	23	047345
990 Lg-14	14	62	100	23	065240

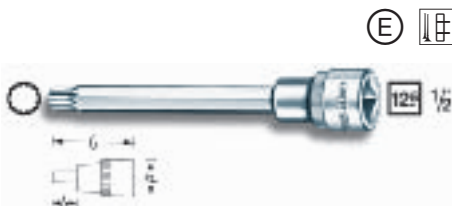

- Extra long style
- For screws with internal serration XZN
- □ drive 12.5 = 1/2"
- Handy and milled
- Blades made of special steel
- For cylinder head screws on different car types, e.g. VW-AUDI, OPEL, TOYOTA

HAZET No.	M	l ₁ mm	l ₂ mm	d mm	EAN-No. 4000896+
990 S Lg-10	10	82	120	23	047369
990 S Lg-12	12	102	140	23	047376

Screwdriver Sockets Sets



- For screws with internal serration XZN
- □ drive 12.5 = 1/2"
- In sheet metal box with plastic insert
- 9 parts

contents:
990-5 6 8 10 12 14 16
991-8 10

HAZET No.	EAN-No. 4000896+
990/9	051557

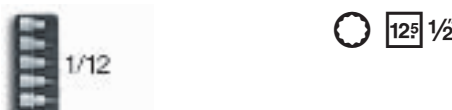

- For screws with internal serration (XZN)
- □ drive 12.5 = 1/2"
- In plastic insert
- 5 parts

contents:
990-5 6 8 10 12

HAZET No.	EAN-No. 4000896+
990-P/5	054053
plastic insert, empty	
2191-1 PL	054350

Screwdriver Sockets Sets



- For screws with internal serration (XZN)
 - Long style
 - □ drive 12.5 = 1/2"
 - In plastic insert
 - 3 parts
- contents:
990 Lg-8
990 S Lg-10 12

HAZET No.	EAN-No. 4000896+
990 S Lg-P/3	054046
Plastic insert, empty	
2191-11 PL	054367

Screwdriver Sockets



- For spline socket screws RIBE CV
- □ drive 12.5 = 1/2"
- Handy and milled
- Blades made of special steel

M 12 = e.g. for cylinder head screws on engines of FIAT 2.0 I

HAZET No.	M	l ₁ mm	l ₂ mm	d mm	EAN-No. 4000896+
991-5	5	25	63	23,0	047444
991-6	6	25	63	23,0	047451
991-8	8	25	63	23,0	047468
991-10	10	25	63	23,0	047406
991-12	12	25	63	23,0	047413
991-14	14	25	63	24,6	047420
991-16	16	25	63	24,6	047437

TORX® Screwdriver Sockets



- Short style
- For inside TORX® screws
- □ drive 12.5 = 1/2"
- Handy and milled
- Blades made of special steel

HAZET No.	mm	l ₁ mm	l ₂ mm	d mm	EAN-No. 4000896+
992-T 20	3,86	17	55	23,0	047475
992-T 25	4,43	17	55	23,0	047482
992-T 27	4,99	17	55	23,0	047499
992-T 30	5,52	17	55	23,0	047505
992-T 40	6,65	17	55	23,0	047512
992-T 45	7,82	17	55	23,0	047529
992-T 50	8,83	17	55	23,0	047543
992-T 55	11,22	18	56	24,6	047574
992-T 60	13,25	18	56	24,6	047598



- Short style
- With bore hole on the face
- For inside tamper TORX® screws (inside TORX® screws with pin)
- □ drive 12.5 = 1/2"
- Handy and milled
- Blades made of special steel

TORX® Screwdriver Sockets

HAZET No.	mm	l ₁ mm	l ₂ mm	d mm	EAN-No. 4000896+
992-T 20 H	3,86	17	55	23	062942
992-T 25 H	4,43	17	55	23	062959
992-T 27 H	4,99	17	55	23	062966
992-T 30 H	5,52	17	55	23	050857
992-T 40 H	6,65	17	55	23	050864
992-T 45 H	7,82	17	55	23	050871
992-T 50 H	8,83	17	55	23	050888
992-T 55 H	11,22	18	56	23	050895
992-T 60 H	13,25	18	56	23	062973



- Long style
- For inside TORX® screws
- □ drive 12.5 = 1/2"
- Handy and milled
- Blades made of special steel

T 70 for cylinder head screws on FORD 1.8 l diesel, (Turbo) Fiesta, Escort, Sierra, P 100 since 8/1992

HAZET No.	mm	l ₁ mm	l ₂ mm	d mm	EAN-No. 4000896+
992 Lg-T 50	8,83	62	100	23,0	103133
992 Lg-T 55	11,22	57	96	23,3	057337
992 Lg-T 60	13,25	45	83	23,0	100590
992 Lg-T 70	15,54	67	105	24,6	047611



- Extra long style
- For inside TORX® screws
- □ drive 12.5 = 1/2"
- Handy and milled
- Blades made of special steel

T45: For intake bridge FORD-Scorpio 2.4 2.8 and 2.9 l injection engine, VW-Passat since April 1989 gearbox type 02 A, 1.6 1.8 and 2.0 l

T55: For cylinder head bolts on various FORD types e.g. Mondeo 16 V

HAZET No.	mm	l ₁ mm	l ₂ mm	d mm	EAN-No. 4000896+
992 S Lg-T 40	6,65	100	100	23	103539
992 S Lg-T 45	7,82	100	100	23	047635
992 S Lg-T 50	8,83	100	100	23	103454
992 S Lg-T 55	11,22	102	102	23	047642

TORX® Screwdriver Socket Set



- For inside TORX® screws
- □ drive 12.5 = 1/2"
- In sheet metal box with plastic insert
- 9 parts

contents:
992-T20 T25 T27 T30 T40 T45 T50 T55 T60

HAZET No.	EAN-No. 4000896+
992/9	051540

Screwdriver Sockets Sets



- For tamper resistant TORX® screws (Inside TORX® screws with pin)
- □ drive 12.5 = 1/2"
- In plastic insert
- 5 parts

contents:
992-T30H T40H T45H T50H T55H

HAZET No.	EAN-No. 4000896+
992 H-P/5	054152
plastic insert, empty	
2191-1 PL	013999

Socket Sets (6-Point)

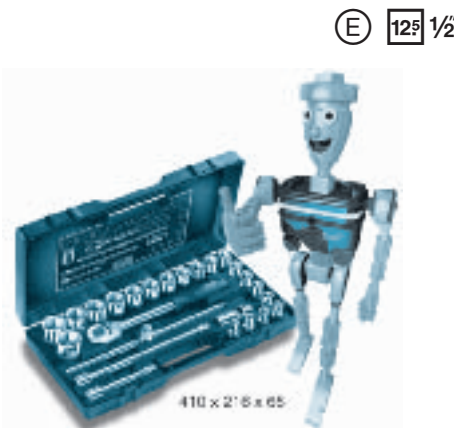

- □ drive 12.5 = 1/2"
- In plastic box with integrated handle
- With PUR foam insert – all tools are snugly embedded
- 25 parts

contents:
900-10 11 12 13 14 15 16 17 18 19
20 21 22 23 24 26 27 28 30 32
915 916 SP 917-5
918-10 920

HAZET No.	EAN-No. 4000896+
900	042685



- □ drive 12.5 = 1/2"
- In plastic box with integrated handle
- With PUR foam insert – all tools are snugly embedded
- 17 parts

contents:
900-10 11 12 13 14 15 17
19 22 24 27 30 32
915 916 SP
917-5 918-10

HAZET No.	EAN-No. 4000896+
906	045891

Socket Sets (6-Point)



- With Spark Plug Sockets
- □ drive 12.5 = 1/2"
- In plastic box with integrated handle
- With PUR foam insert – all tools are snugly embedded
- 18 parts

contents:
900-12 13 14 15 16 17 18
19 21 22 24 27 30 32
900 AKF 900 KF
916 SP 918-10

HAZET No.	EAN-No. 4000896+
907	045952



- □ drive 12.5 = 1/2"
- In plastic box with integrated handle
- With PUR foam insert – all tools are snugly embedded
- 15 parts

contents:
900-10 11 12 13 14 16
17 18 19 21 22 24
916 SP 918-10 920

HAZET No.	EAN-No. 4000896+
932 N	046553



- Combinational set with □ drive 6.3 = 1/4" and □ drive 12.5 = 1/2"
- In plastic box with integrated handle
- With PUR foam insert – all tools are snugly embedded
- 23 parts

contents:
850-5 5,5 6 7 8 10 11
863 P 867-4 869
900-12 13 14 15 16 17 18 19 21 22
916 SP 917-5 920

HAZET No.	EAN-No. 4000896+
938 N	046607

Socket Sets (6-Point)

(E) 12.5 1/2"



410 x 215 x 65

- With Screwdriver Sockets, Bits and Adapter
- □ drive 12.5 = 1/2"
- In plastic box with integrated handle
- With PUR foam insert – all tools are snugly embedded
- 44 parts

contents:

900-10 11 12 13 14 15 17 19 20
21 22 23 24 26 27 28 30 32
915 916SP
917-5 918-10 920
986-5 6 7 8 10 12 14
2217- PH1 PH2 PH3 PH4
2218- PZ1 PZ2 PZ3 PZ4
2224- T27 T30 T40 T45 T50
2250-5

HAZET No. EAN-No. 4000896+

954 N 046621

(E) 12.5 1/2"



410 x 215 x 65

- American sizes
- □ drive 12.5 = 1/2"
- In plastic box with integrated handle
- With PUR foam insert – all tools are snugly embedded
- 20 parts

contents:

900 A- 3/8 7/16 1/2 9/16 5/8
1 1/16 3/4 13/16 7/8 15/16
1 1.1/16 1.1/8 1.3/16 1.1/4
915 916SP 917-5
918-10 920

HAZET No. EAN-No. 4000896+

900 A N 043514



Socket Sets (12-Point)

(E) 12.5 1/2"



410 x 216 x 55

- □ drive 12.5 = 1/2"
- In plastic box with integrated handle
- With PUR foam insert – all tools are snugly embedded
- 25 parts

contents:

900 Z-10 11 12 13 14 15 16 17 18 19
20 21 22 23 24 26 27 28 30 32
915 916SP 917-5
918-10 920

HAZET No. EAN-No. 4000896+

900 Z 045440

(E) 12.5 1/2"



410 x 210 x 55

- □ drive 12.5 = 1/2"
- In plastic box with integrated handle
- With PUR foam insert – all tools are snugly embedded
- 17 parts

contents:

900 Z-10 11 12 13 14 15 17
19 22 24 27 30 32
915 916SP 917-5 918-10

HAZET No. EAN-No. 4000896+

906 Z 045945

(E) 12.5 1/2"



344 x 188 x 58

- □ drive 12.5 = 1/2"
- In plastic box with integrated handle
- With PUR foam insert – all tools are snugly embedded
- 15 parts

contents:

900 Z-10 11 12 13 14 16
17 18 19 21 22 24
916SP 918-10 920

HAZET No. EAN-No. 4000896+

932 Z N 046584

Socket Sets (12-Point)

(E) 12.5 1/2"



410 x 215 x 65

- American sizes
- □ drive 12.5 = 1/2"
- In plastic box with integrated handle
- With PUR foam insert – all tools are snugly embedded
- 23 parts

contents:

900 AZ- 3/8 7/16 1/2 9/16 19/32 5/8
1 1/16 3/4 25/32 13/16 7/8 15/16
31/32 1 1.1/16 1.1/8 1.3/16 1.1/4
915 916SP 917-5 918-10 920

HAZET No. EAN-No. 4000896+

900 A Z 043569

(E) 12.5 1/2"



410 x 215 x 65

- American sizes
- □ drive 12.5 = 1/2"
- In plastic box with integrated handle
- With PUR foam insert – all tools are snugly embedded
- 18 parts

contents:

900 AZ- 3/8 7/16 1/2 9/16 5/8 11/16 3/4 13/16
7/8 15/16 1 1.1/16 1.1/8 1.3/16 1.1/4
916SP 918-10 920

HAZET No. EAN-No. 4000896+

932 AZ N 046539

(E) 12.5 1/2"



410 x 216 x 65

- American sizes and metric sizes
- □ drive 12.5 = 1/2"
- In plastic box with integrated handle
- With PUR foam insert – all tools are snugly embedded
- 36 parts

contents:

900 Z-10 11 12 13 14 15 16 17
18 19 21 22 24 27 30 32
900 AZ- 3/8 7/16 1/2 9/16 5/8 11/16 3/4 13/16
7/8 15/16 1 1.1/16 1.1/8 1.3/16 1.1/4
915 916SP 917-5 918-10 920

HAZET No. EAN-No. 4000896+

907 AM Z 045969

Socket Set (6-Point)



(E) 12.5 1/2"

- drive 12.5 = 1/2"
- In sheet metal box with plastic insert
- 31 parts

contents:

900-8	9	10	11	12	13	14	15
16	17	18	19	20	21	22	23
24	25	26	27	28	30	32	
911	914-15	915	916SP				
917-5	918-10	920	980-2 x 13				

HAZET No.	EAN-No. 4000896+
905	045846

Socket Sets (12-Point)



(E) 12.5 1/2"

- drive 12.5 = 1/2"
- In sheet metal box with plastic insert
- 31 parts

contents:

900Z-8	9	10	11	12	13	14	15
16	17	18	19	20	21	22	23
24	25	26	27	28	30	32	
911	914-15	915	916SP				
917-5	918-10	920	980-2 x 13				

HAZET No.	EAN-No. 4000896+
905 Z	045877



(E) 12.5 1/2"

- American sizes
- drive 12.5 = 1/2"
- In sheet metal box with plastic insert
- 26 parts

contents:

900AZ-3/8	7/16	1/2	9/16	19/32	5/8 ¹
1/16	3/4	25/32	13/16	7/8	15/16
31/32	1	1 1/16	1 1/8	1 3/16	1 1/4
911	914-15	915	916SP		
917-5	918-10	920	980-2 x 13		

HAZET No.	EAN-No. 4000896+
905 AZ	045853

Socket Sets (6-Point)



12.5 1/2"

- drive 12.5 = 1/2"
- Easy installation: with 2 bore holes for e.g. wall fixation
- With clips suitable for the corresponding socket drive
- Clear arrangement on rail keeps sockets always ready to hand
- Made of metal

HAZET No.	l mm	EAN-No. 4000896+
-----------	------	------------------

14 6-Point Sockets

contents:

900-10	11	12	13	14	15	16
17	18	19	21	22	24	27

900/14 H	430	051779
----------	-----	--------

with 16 socket clips, empty, suitable for sockets of 900 series

900 HL	430	043842
--------	-----	--------

6-Point Sockets



- drive 20 = 3/4"
- Handy and milled
- For manual operation
- With locking pin
- Chrome-Vanadium
- Surface chrome-plated, polished
- DIN 3124, ISO 2725-1

* = not according to DIN

HAZET No.	l mm	d ₁ mm	d ₂ mm	t mm	EAN-No. 4000896+
1000-19*	52,0	28,0	33,2	14,2	000623
1000-21	52,0	31,0	33,2	14,0	000647
1000-22*	52,0	32,0	33,2	13,5	000654
1000-24	52,0	34,0	36,0	16,0	000661
1000-27	54,0	38,0	35,0	18,8	000678
1000-30	55,0	42,0	36,0	21,0	000692
1000-32	58,0	44,5	36,0	23,4	000708
1000-33	59,0	46,0	36,0	23,9	000715
1000-34	60,0	47,5	36,0	24,8	000722
1000-36	61,5	49,5	36,0	25,7	000746
1000-38*	65,0	52,5	36,0	28,3	000760
1000-41	68,5	55,5	39,0	31,2	000784
1000-42*	70,0	57,5	41,0	31,2	000791
1000-46	73,0	62,0	44,0	34,0	000807
1000-50	76,0	67,0	45,0	37,1	000814
1000-55*	82,0	73,5	45,0	40,8	000821
1000-60*	88,0	80,0	45,0	44,9	000838

12-Point Sockets



- drive 20 = 3/4"
- Handy and milled
- For manual operation
- With locking pin
- Chrome-Vanadium
- Surface chrome-plated, polished
- DIN 3124, ISO 2725-1

12-Point Sockets

* = not according to DIN

HAZET No.	l mm	d ₁ mm	d ₂ mm	t mm	EAN-No. 4000896+
1000 Z-19*	52,0	28,0	33,2	14,2	001484
1000 Z-21	52,0	31,0	33,2	14,0	001491
1000 Z-22*	52,0	32,0	33,2	13,5	001507
1000 Z-24	52,0	34,0	36,0	16,0	001521
1000 Z-27	54,0	38,0	35,0	18,8	001552
1000 Z-30	55,0	42,0	36,0	21,0	001583
1000 Z-32	58,0	44,5	36,0	23,4	001590
1000 Z-33*	59,0	46,0	36,0	23,9	001606
1000 Z-34	60,0	47,5	36,0	24,8	001613
1000 Z-35*	61,5	48,5	35,5	25,8	001620
1000 Z-36	61,5	49,5	36,0	25,7	001637
1000 Z-38*	65,0	52,5	38,0	28,3	001644
1000 Z-41	68,5	55,5	39,0	31,2	001651
1000 Z-42*	70,0	57,5	41,0	31,2	001668
1000 Z-46	73,0	62,0	44,0	34,0	001675
1000 Z-50	76,0	67,0	45,0	37,1	001699
1000 Z-55	82,0	78,5	45,0	40,8	001712
1000 Z-60	88,0	80,0	45,0	44,9	001729



- American sizes
- drive 20 = 3/4"
- Handy and milled
- For manual operation
- With locking pin
- Chrome-Vanadium
- Surface chrome-plated, polished

HAZET No.	l mm	d ₁ mm	d ₂ mm	t mm	EAN-No. 4000896+
1000 AZ-3/8	52,0	28,0	33,2	14,0	001163
1000 AZ-7/8	52,0	32,0	33,2	13,5	001170
1000 AZ-15/16	52,0	34,0	36,0	16,9	001132
1000 AZ-1	52,0	36,5	33,2	16,9	000999
1000 AZ-1 1/16	54,0	38,0	35,0	18,8	001002
1000 AZ-1 1/8	55,0	40,0	36,0	20,8	001033
1000 AZ-1 3/16	55,0	42,0	36,0	21,0	001064
1000 AZ-1 1/4	58,0	44,5	36,0	23,4	001026
1000 AZ-1 5/16	59,0	46,0	36,0	23,9	001095
1000 AZ-1 3/8	61,5	48,5	36,0	25,8	001088
1000 AZ-1 7/16	63,0	50,0	36,0	27,2	001118
1000 AZ-1 1/2	65,0	52,5	38,0	28,6	001019
1000 AZ-1 5/8	68,5	55,5	39,0	31,2	001101
1000 AZ-1 11/16	71,0	58,0	41,0	33,1	001040
1000 AZ-1 3/4	72,0	60,0	41,0	33,6	001071
1000 AZ-1 13/16	73,0	62,0	44,0	34,0	001057
1000 AZ-1 7/8	73,0	64,0	45,0	35,0	001125
1000 AZ-2	78,0	68,0	45,0	38,7	001149
1000 AZ-2 1/4	85,0	76,5	45,0	42,0	001156

Screwdriver Sockets

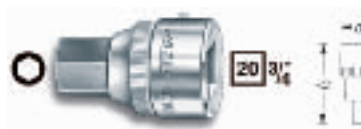

- drive 20 = 3/4"
- For inside hexagon screws
- Handy and milled
- For manual operation
- With locking pin
- Chrome-Vanadium
- Surface chrome-plated, polished
- DIN 7422

HAZET No.	l ₁ mm	l ₂ mm	l ₃ mm	d mm	EAN-No. 4000896+
1010-14	16,7	54,5	27,2	36	001842
1010-17	19,7	54,5	27,2	36	001859
1010-19	21,7	56,5	29,2	36	001866
1010-22	24,7	56,5	29,2	36	001873

TORX® Screwdriver Sockets



- For the operation of inside TORX® screws e.g. of commercial vehicles and agricultural machinery
- Application e.g. at the front axle: screws of the steering tie lever on commercial vehicles MAN
- 1012-T 80 for M series
1012-T 100 for F series
- Blades made of special steel

HAZET No.	l ₁ mm	l ₂ mm	mm	EAN-No. 4000896+
1012-T 60	52	80	13,25	087488
1012-T 70	52	80	15,53	087495
1012-T 80	52	80	17,59	087501
1012-T 90	52	80	19,95	087518
1012-T 100	52	80	22,15	087525

Handle Bars



- With ball and pin locking device
- For Sliding Head HAZET 1015-1 or Ratchet Head HAZET 1016
- Chrome-Vanadium
- Surface chrome-plated

HAZET No.	l mm	EAN-No. 4000896+
1014	500	001897



- With HAZET-ergonomic plastic handle
- With pin locking device
- For Sliding Head HAZET 1015-1 or Ratchet Head HAZET 1016
- Chrome-Vanadium
- Surface chrome-plated

HAZET No.	l mm	EAN-No. 4000896+
1014 P	505	001903

Sliding Head



- ■ drive 20 = 3/4"
- With ball locking device
- For Handle Bar HAZET 1014 or 1014 P
- Chrome-Vanadium
- Surface chrome-plated, polished

HAZET No.	l mm	EAN-No. 4000896+
1015-1	60	001910

Handle Bar with Sliding Head



- ■ drive 20 = 3/4"
- 2 parts:
- Handle Bar HAZET 1014 and Sliding Head 1015-1
- Chrome-Vanadium
- Surface chrome-plated, polished

contents:
1014 1015-1

HAZET No.	l mm	EAN-No. 4000896+
1015/2	500	001927

Reversible Ratchet Head



- ■ drive 20 = 3/4"
- ■ with ball and pin locking device
- Shank with locking pin
- Ratchet wheel 32 teeth
- Chrome-Vanadium
- Surface chrome-plated

HAZET No.	l mm	EAN-No. 4000896+
1016	165	001941



Repair Set for shift lever

consisting of: shift lever, screws, ball, compression spring for 1016, 1016/2, 6132-1 CT, 6143 CT, 6143-1 CT, 6144 CT, 6144-1 CT, 6145 CT, 6145-1 CT, 6146-1 CT

1016/6	001972
--------	--------

Repair Set for ratchet wheel 20 = 3/4" ■

consisting of: ratchet wheel, pawl, shift lever, screws, ball, compression spring for 1016, 1016/2, 6132-1 CT, 6143 CT, 6143-01, 6143-1 CT, 6144 CT, 6144-01, 6144-1 CT, 6145 CT, 6145-01, 6145-1 CT, 6146-1 CT

1016/8 N	001989
----------	--------

Reversible Ratchet with Handle Bar



- ■ drive 20 = 3/4"
- Chrome-Vanadium
- Surface chrome-plated, polished
- DIN 3122, ISO 3315

contents:
1014 P 1016

HAZET No.	l mm	EAN-No. 4000896+
1016/2	620	001965

Extensions



- □ ■ drive 20 = 3/4"
- ■ with ball and pin locking device
- □ with locking pin
- Chrome-Vanadium
- Surface chrome-plated, polished

1017-8 = DIN 3123, ISO 3316

HAZET No.	l mm	EAN-No. 4000896+
1017-3	75	001996
1017-8	200	002016

Extensions



- □ ■ drive 20 = 3/4"
- DIN 3123, ISO 3316

HAZET No.	l mm	EAN-No. 4000896+
1018	400	002030

Universal Joint



- □ ■ drive 20 = 3/4"
- ■ with ball and pin locking device
- □ with locking pin
- Chrome-Vanadium
- Surface chrome-plated
- DIN 3123, ISO 3316

HAZET No.	l mm	EAN-No. 4000896+
1021	105	002054

Adapters



- □ drive 20 = 3/4"
- □ with locking pin
- Chrome-Vanadium
- Surface chrome-plated
- DIN 3123, ISO 3316

HAZET No.	l mm	EAN-No. 4000896+
-----------	------	------------------

- ■ drive 25 = 1" with locking pin

1058-1	60,6	002061
--------	------	--------

- ■ drive 12.5 = 1/2" with locking ball

1058-2	52,3	002078
--------	------	--------

Socket Sets (6-Point)



- □ drive 20 = 3/4"
- In sheet metal box with plastic insert
- 15 parts

contents:
1000-22 24 27 30 32 36 38 41 46 50
1014 1015-1 1016 1017-8 1018

HAZET No.	EAN-No. 4000896+
1000	000616

Socket Sets (6-Point)



(E) 20 3/4"

- drive 20 = 3/4"
- In sheet metal box with plastic insert
- 18 parts

contents:

 1000-22 24 27 30 32 36
38 41 46 50 55 60
1014 1015-1 1016 1017-8 1018 1021

HAZET No.	EAN-No. 4000896+
1002	001736

Socket Sets (12-Point)



(E) 20 3/4"

- drive 20 = 3/4"
- In sheet metal box with plastic insert
- 15 parts

contents:

 1000 Z-22 24 27 30 32 36 38 41 46 50
1014 1015-1 1016 1017-8 1018

HAZET No.	EAN-No. 4000896+
1000 Z	001477



(E) 20 3/4"

- drive 20 = 3/4"
- In sheet metal box with plastic insert
- 18 parts

contents:

 1000 Z-22 24 27 30 32 36 38 41 46 50
1000-55 60
1014 1015-1 1016 1017-8 1018 1021

HAZET No.	EAN-No. 4000896+
1002 Z	001743

Socket Sets (12-Point)



(E) 20 3/4"

- American sizes
- drive 20 = 3/4"
- In sheet metal box with plastic insert
- 21 parts

contents:

 1000 AZ-7/8 15/16 1.1/16 1.1/8 1.3/16
1.1/4 1.5/16 1.3/8 1.7/16 1.1/2
1.5/8 1.3/4 1.13/16 1.7/8 2
1014 1015-1 1016 1017-8 1018

HAZET No.	EAN-No. 4000896+
1000 AZ	000982

12-Point Sockets



- drive 25 = 1"
- Handy and milled
- For manual operation
- With locking pin
- Chrome-Vanadium
- Surface chrome-plated, polished
- DIN 3124, ISO 2725

* = not according to DIN

HAZET No.	l mm	d ₁ mm	d ₂ mm	t mm	EAN-No. 4000896+
1100 Z-32 *	67	48,0	46	23,4	002511
1100 Z-34 *	68	51,0	46	23,3	049677
1100 Z-36 *	66	52,0	48	29,0	002528
1100 Z-41	70	57,0	48	32,0	002535
1100 Z-46	75	62,0	48	34,3	002542
1100 Z-50	80	68,0	48	37,0	002559
1100 Z-55	85	74,0	48	39,5	002566
1100 Z-60	90	80,0	48	42,0	002573
1100 Z-65	105	88,0	60	48,0	002580
1100 Z-70	110	96,0	60	50,5	002603
1100 Z-75	115	102,0	60	53,0	002610
1100 Z-80	120	108,5	60	55,5	002627

Handle Bar



- With ball and pin locking device
- For Sliding Head HAZET 1115-1 or Ratchet Head HAZET 1116
- Chrome-Vanadium
- Surface chrome-plated

HAZET No.	l mm	EAN-No. 4000896+
1114	700	003150

Sliding Head



- drive 25 = 1"
- With ball locking device
- For Handle Bar HAZET 1114
- Chrome-Vanadium
- Surface chrome-plated, polished

HAZET No.	l mm	EAN-No. 4000896+
1115-1	80	003167

Handle Bar with Sliding Head



- drive 25 = 1"
- 2 parts: Handle Bar HAZET 1114 and Sliding Head 1115-1
- Chrome-Vanadium
- Surface chrome-plated, polished

contents:

1114 1115-1

HAZET No.	l mm	EAN-No. 4000896+
1115/2	700	003181

Reversible Ratchet Head



- drive 25 = 1"
- with ball and pin locking device
- Shank with locking pin
- Ratchet wheel 32 teeth
- Chrome-Vanadium
- Surface chrome-plated

HAZET No.	l mm	EAN-No. 4000896+
1116	195	003198



Repair Set for shift lever

consisting of: shift lever, screws, ball, compression spring for 1116

1116/6	003228
--------	--------

Repair Set for ratchet wheel 25 = 1" ■

consisting of: shift lever, screws, ball, compression spring, pawl, ratchet wheel for 1116

1116/8 N	003235
----------	--------

Reversible Ratchet with Handle Bar



- drive 25 = 1"
- Chrome-Vanadium
- Surface chrome-plated, polished
- DIN 3122, ISO 3315

contents:
1114 1116

HAZET No.	l mm	EAN-No. 4000896+
1116/2	824	003211

Extensions



- drive 25 = 1"
- with ball and pin locking device
- with locking pin
- Chrome-Vanadium
- Surface chrome-plated, polished
- DIN 3123, ISO 3316

HAZET No.	l mm	EAN-No. 4000896+
1117- 8	200	003259
1117-16	400	003242

Universal Joint

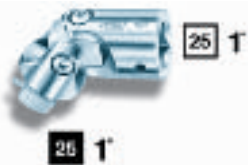

- drive 25 = 1"
- with ball and pin locking device
- with locking pin
- Chrome-Vanadium
- Surface chrome-plated

HAZET No.	l mm	EAN-No. 4000896+
1121	144	003273

Adapter



- drive 25 = 1"
- with locking pin
- drive 20 = 3/4"
- with ball and pin locking device
- Chrome-Vanadium
- Surface chrome-plated
- DIN 3123, ISO 3316

HAZET No.	l mm	EAN-No. 4000896+
1158-2	70	003297

Socket Set (12-Point)



- drive 25 = 1"
- In sheet metal box
- 17 parts

contents:
1100 Z-32 36 41 46 50 55 60 65 70 75 80
1114 1115-1 1116 1117-8 16 1121

HAZET No.	EAN-No. 4000896+
1100 Z	002504

IMPACT SOCKETS AND SOCKET SETS

6-Point Sockets



- Suitable for all types of electric and pneumatic screw driving machines (**screwdrivers and impact wrenches**)
- For excessive use
- Depending on the execution of the screw driving machines, the sockets are connected through steel pins and rubber rings or safety springs to the screw driving machines
- Chrome-Vanadium special steel
- Surface burnished
- drive 6.3 = 1/4"
- DIN 3129, ISO 2725

HAZET No.	l mm	d ₁ mm	d ₂ mm	EAN-No. 4000896+
850 S- 6	25	9,8	13	037759
850 S- 7	25	11,0	13	037773
850 S- 8	25	12,2	13	037797
850 S-10	25	15,0	13	037711

- With permanent magnet
- For impact operation
- drive 6.3 = 1/4"

HAZET No.	l mm	d ₁ mm	d ₂ mm	t mm	EAN-No. 4000896+
850 S Mg- 7	25	10,9	13	2,5	038039
850 S Mg- 8	25	12,2	13	2,5	038053
850 S Mg-10	25	15,0	13	4,2	038015

TORX® Sockets



- For outside TORX® screws
- For impact operation
- drive 6.3 = 1/4"

HAZET No.	l mm	d ₁ mm	d ₂ mm	EAN-No. 4000896+	
850 S-E 4	3,86	25	5,6	13	037841
850 S-E 5	4,75	25	6,7	13	037872
850 S-E 6	5,74	25	8,0	13	037902
850 S-E 7	6,22	25	9,6	13	037933
850 S-E 8	7,52	25	10,5	13	037964
850 S-E 10	9,42	25	13,0	13	037810

Extensions



- For impact operation
- drive 6.3 = 1/4"

HAZET No.	l mm	EAN-No. 4000896+
8505 S-2	51	037261
8505 S-6	152	037278

Adapters



- drive 6.3 = 1/4" (DIN 3121)
- A 5.5 DIN 3126, Form A
- For impact sockets with drive 6.3 = 1/4"
- For the application on screw driving machines e.g. for AEG, Bosch, Holzher, Metabo

HAZET No.	l mm	EAN-No. 4000896+
8508 S-1	50	037391



- drive 6.3 = 1/4" (DIN 3121)
- E 6.3 DIN 3126, Form E (1/4")
- For the application on screw driving machines e.g. for AEG, Atlas-Copco, Black / Decker, Bosch

HAZET No.	l mm	EAN-No. 4000896+
8508 S-3	50	037414
8508 S-4	100	037421



- drive 6.3 = 1/4" (DIN 3121)
- 7 outside flat end, form G
- For the application on screw driving machines e.g. for Beier, Fein

HAZET No.	l mm	EAN-No. 4000896+
8508 S-5	75	037438

6-Point Sockets



- Suitable for all types of electric and pneumatic screw driving machines (**screwdrivers and impact wrenches**)
- For excessive use
- drive 10 = 3/8"
- Chrome-Vanadium special steel
- Surface burnished
- DIN 3129, ISO 2725-2

HAZET No.	l mm	d ₁ mm	d ₂ mm	t mm	EAN-No. 4000896+
880 S- 7	28	11,8	19	5,0	041176
880 S- 8	28	13,0	19	5,9	041190
880 S-10	28	15,5	19	6,7	040957
880 S-11	28	16,7	19	7,8	040971
880 S-12	28	18,0	19	7,7	040995
880 S-13	32	19,4	22	9,2	041015
880 S-14	32	20,7	22	9,2	041039
880 S-15	32	21,5	22	10,2	041053
880 S-16	32	23,4	22	11,2	041077
880 S-17	32	24,9	22	11,2	041091
880 S-18	32	26,3	22	14,0	041114
880 S-19	32	27,7	22	14,0	041138

TORX® Sockets



- For outside TORX® screws
- For impact operation
- □ drive 10 = 3/8"

HAZET No.	mm	l mm	d ₁ mm	d ₂ mm	EAN-No. 4000896+
880 S-E 6	6	5,74	28	9,0	041312
880 S-E 7	7	6,22	28	10,0	041336
880 S-E 8	8	7,52	28	11,5	041350
880 S-E 10	10	9,42	28	14,0	041237
880 S-E 12	12	11,17	28	15,9	041251
880 S-E 14	14	12,90	28	17,7	041275

Extensions



- For impact operation
- □ drive 10 = 3/8"

HAZET No.	l mm	EAN-No. 4000896+
8805 S-3	78	039821
8805 S-6	152	039838

Universal Joint



- For impact operation
- □ drive 10 = 3/8"

HAZET No.	l mm	EAN-No. 4000896+
8806 S	51,5	039883

Adapters



- For impact operation
- □ drive 10 = 3/8"

HAZET No.	l mm	□	EAN-No. 4000896+
■ drive 6.3 = 1/4"			
8807 S	28,0	10 = 3/8"	039937
■ drive 12.5 = 1/2"			
8807 S-1	35,5	10 = 3/8"	039951

Adapter

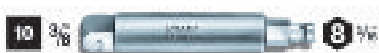

- ■ drive 10 = 3/8" (DIN 3121)
- ● 8 = 5/16"
- For impact sockets with □ drive 10 = 3/8"

HAZET No.	l mm	EAN-No. 4000896+
8808 S-1	75	040032

6-Point Sockets

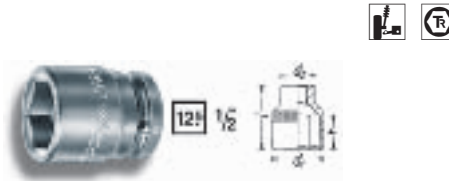

- Suitable for all types of electric and pneumatic screw driving machines (**screwdrivers and impact wrenches**)

- For excessive use
- □ drive 12.5 = 1/2"
- Chrome-Vanadium special steel
- Surface burnished
- DIN 3129, ISO 2725-2

* = not according to DIN
+ = reinforced design, with deep hexagon profile for wheel nuts/bolts

HAZET No.	l mm	d ₁ mm	d ₂ mm	t mm	EAN-No. 4000896+
900 S-8	38	14,3	25	6,0	044511
900 S-10	38	16,8	25	7,5	044085
900 S-11	38	18,1	25	8,5	044108
900 S-12	38	19,5	25	8,5	044122
900 S-13	38	20,8	25	10,0	044146
900 S-14	38	22,1	25	10,0	044177
900 S-15	38	23,5	30	11,0	044191
900 S-16	38	24,8	30	11,0	044214
900 S-17	38	26,2	30	12,0	044238
900 S-17 R +	38	30,0	30	14,0	044252
900 S-18	38	27,5	30	12,0	044283
900 S-19	40	28,8	30	15,0	044306
900 S-19 R +	42	32,8	30	18,0	044313
900 S-20 *	40	29,5	30	15,0	044344
900 S-21	40	31,3	30	15,0	044368
900 S-22	40	32,5	30	15,0	044382
900 S-23 *	40	33,8	30	15,0	044405
900 S-24	44	35,0	30	17,5	044429
900 S-24 R +	45	38,8	30	16,5	044436
900 S-25 *	44	36,3	30	18,5	044450
900 S-26 *	44	37,6	30	18,5	044474
900 S-27	45	38,8	30	19,5	044498
900 S-30	50	42,0	30	23,3	073207
900 S-32 *	50	44,0	30	23,0	073184



- Long style
- For impact operation
- □ drive 12.5 = 1/2"

+ = reinforced design, with deep hexagon profile for wheel nuts/bolts

HAZET No.	l mm	d ₁ mm	d ₂ mm	t mm	EAN-No. 4000896+
900 S Lg-13	85	20,8	25	13,0	044764
900 S Lg-16	85	24,8	30	16,0	044788
900 S Lg-17	85	26,2	30	16,0	044801
900 S Lg-18	85	27,5	30	19,0	044825
900 S Lg-19	85	28,8	30	19,0	044849
900 S Lg-21 +	85	31,3	30	17,5	044863
900 S Lg-22	85	32,5	30	17,5	044887
900 S Lg-24	85	35,0	30	17,5	044917
900 S Lg-27	85	38,8	30	19,5	044931

- Long style for wheel nuts/bolts e.g. on JAPANESE and American vehicles
- □ drive 12.5 = 1/2"

HAZET No.	l mm	d ₁ mm	d ₂ mm	t mm	EAN-No. 4000896+
900 A S Lg-13/16	85	31,3	30	17,5	043538

12-Point Sockets



- For impact operation
- □ drive 12.5 = 1/2"
- s 30 for the axle shaft nut on VW Golf 4, Polo, New Beetle and AUDI TT 1.8
- s 36 for the axle shaft nut on BMW 5-series

HAZET No.	l mm	d ₁ mm	d ₂ mm	t mm	EAN-No. 4000896+
900 S Z-12	38	19,5	25	7,5	061785
900 S Z-13	38	20,8	25	7,5	061792
900 S Z-14	38	22,1	25	10,0	061808
900 S Z-15	38	23,5	30	10,0	061815
900 S Z-16	38	24,8	30	10,0	061822
900 S Z-17	38	26,2	30	10,0	061839
900 S Z-18	38	27,5	30	11,5	061846
900 S Z-19	40	28,8	30	12,5	061853
900 S Z-21	40	31,5	30	13,0	075362
900 S Z-22	40	32,5	30	13,0	075379
900 S Z-30	50	42,0	30	23,0	086573
900 S Z-36	60	50,0	30	27,5	100132

TORX® Sockets



- For outside TORX® screws
- For impact operation
- □ drive 12.5 = 1/2"

HAZET No.	mm	l mm	d ₁ mm	d ₂ mm	EAN-No. 4000896+
900 S-E 10	9,42	38,0	14,0	25	044542
900 S-E 12	11,17	38,0	15,9	25	044566
900 S-E 14	12,90	38,0	17,7	25	044580
900 S-E 16	14,76	38,0	20,0	25	044603
900 S-E 18	16,70	38,0	22,0	30	044627
900 S-E 20	18,45	38,0	24,5	30	044641
900 S-E 24	22,16	41,2	30,0	30	044665

6-Point Sockets



- Especially for mounting and dismounting wheels
- Long and extra-slim style
- For impact operation
- □ drive 12.5 = 1/2"

HAZET No.	l mm	d ₁ mm	d ₂ mm	t mm	EAN-No. 4000896+
901 S Lg-17	85	25,7	30	16,0	045723
901 S Lg-19	85	28,2	30	19,0	045747



- Especially for mounting and dismounting wheels
- Long and extra-slim style
- For impact operation
- **With plastic insert** to protect the surface of wheel nuts/bolts
- □ drive 12.5 = 1/2"
- s 17 = e.g. for wheel screws on MERCEDES-BENZ passenger cars

HAZET No.	l mm	d ₁ mm	d ₂ mm	t mm	EAN-No. 4000896+
902 S Lg-17	85	25,7	30	14,0	045778
902 S Lg-19	85	28,2	30	18,0	045792

6-Point Sockets



(E)

- Especially for mounting and dismounting wheels
- Long style
- For impact operation
- **With plastic insert** to protect the surface of wheel nuts and bolts
- In addition with **outside plastic sleeve** to protect the rims when screwing the wheel nuts/bolts
- Replaceable plastic sleeve
- □ drive 12.5 = 1/2"

HAZET No.	l mm	d ₁ mm	d ₂ mm	t mm	EAN-No. 4000896+
-----------	------	-------------------	-------------------	------	------------------

903 S Lg-15: especially for Smart

903 S Lg-15 85 26 30 14,0 072231

903 S Lg-17 85 30 30 16,0 045822

903 S Lg-19 85 30 30 19,0 045839

especially for Japanese cars and Smart For-Four

903 S Lg-21 85 30 31 17 055135

Set with 3 parts: 903 S Lg-17 19 21

903 S Lg/3 - - - - 060344

Plastic Sleeves

HAZET No.	EAN-No. 4000896+
-----------	------------------

903 S Lg-015 081462

903 S Lg-017 045808

903 S Lg-019 045815

903 S Lg-021 055692

6-Point Socket



- Especially for mounting and dismounting wheels on AMG-rims and/or alloy rims with deeply located wheel nuts
- **Extra long style**
- For impact operation
- **With plastic insert** to protect the surface of wheel nuts and bolts
- In addition with **outside plastic sleeve** to protect the rims when screwing the wheel nuts/bolts
- Replaceable plastic sleeve
- □ drive 12.5 = 1/2"

HAZET No.	l mm	d ₁ mm	d ₂ mm	t mm	EAN-No. 4000896+
-----------	------	-------------------	-------------------	------	------------------

904 S Lg-17 130 28,3 30 18,3 100576

Extensions



- For impact operation
- □ drive 12.5 = 1/2"

HAZET No.	l mm	EAN-No. 4000896+
-----------	------	------------------

9005 S- 2 52 043156

9005 S- 5 130 043163

9005 S-10 255 043149

Universal Joint



- For impact operation
- □ drive 12.5 = 1/2"

HAZET No.	l mm	EAN-No. 4000896+
-----------	------	------------------

9006 S 69 043170

Adapters

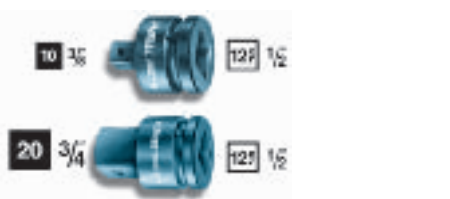

- For impact operation
- □ drive 12.5 = 1/2"

HAZET No.	l mm	EAN-No. 4000896+
-----------	------	------------------

■ drive 10 = 3/8"

9007 S 37 072545

■ drive 20 = 3/4"

9007 S-1 49 043217

Adapters



- ■ drive 12.5 = 1/2" (DIN 3121)
- ● E 11 = 7/16" (DIN 3126)
- For impact sockets with □ drive 12.5 = 1/2"

HAZET No.	l mm	EAN-No. 4000896+
-----------	------	------------------

9008 S-1 75 043231



- ■ drive 12.5 = 1/2" (DIN 3121)
- ● E 8 = 9/16"
- For impact sockets with □ drive 12.5 = 1/2"

HAZET No.	l mm	EAN-No. 4000896+
-----------	------	------------------

9008 S-2 75 043248

TORX® Screwdriver Sockets



- For inside TORX® screws
- For impact operation
- □ drive 12.5 = 1/2"

HAZET No.	d mm	l ₁ mm	l ₂ mm	d mm	EAN-No. 4000896+
-----------	------	-------------------	-------------------	------	------------------

995 S-T 30 5,52 21,4 40 25,1 047666

995 S-T 40 6,65 21,1 40 25,1 047680

995 S-T 45 7,82 21,1 40 25,1 057597

995 S-T 50 8,83 22,4 40 25,1 047703

995 S-T 55 11,22 22,4 40 25,1 047727

995 S-T 60 13,25 22,1 40 25,1 047741

6-Point Socket Set



(E) 12.5 1/2

- For impact operation
- □ drive 12.5 = 1/2"
- In sheet metal box
- With plastic insert
- 23 parts

contents:

900 S-13 14 16 17 18

19 21 22 24 27

900 S Lg-13 16 17 18 19

21 22 24 27

900 -HF 1530 HF 814

9005 S-5

9006 S

HAZET No.	EAN-No. 4000896+
-----------	------------------

900 S 057153

6-Point Sockets

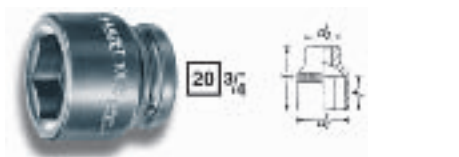

- Suitable for all types of electric and pneumatic screw driving machines (**screwdrivers and impact wrenches**)

- For excessive use
- □ drive 20 = 3/4"
- Chrome-Vanadium special steel
- Surface burnished
- DIN 3129, ISO 2725-2

* = not according to DIN

HAZET No.	l mm	d ₁ mm	d ₂ mm	t mm	EAN-No. 4000896+
-----------	------	-------------------	-------------------	------	------------------

1000 S-17 48 29,0 44 12 001217

1000 S-18 48 30,5 44 13 001224

1000 S-19 48 32,0 44 13 001231

1000 S-22 50 36,5 44 16 001248

1000 S-24 50 39,5 44 17 001255

1000 S-27 51 43,5 44 19 001262

1000 S-28* 54 45,0 44 19 001279

1000 S-29* 54 46,0 44 20 001286

1000 S-30 54 47,4 44 21 001293

1000 S-32 54 49,9 44 21 001309

1000 S-33* 54 51,5 44 21 001316

1000 S-34 54 52,4 44 22 001323

1000 S-36 57 54,9 44 23 001330

1000 S-38* 58 58,0 44 24 001347



- Long style
- For impact operation
- □ drive 20 = 3/4"

6-Point Sockets

HAZET No.	l mm	d ₁ mm	d ₂ mm	t mm	EAN-No. 4000896+
1000 S Lg-21	100	35,0	44	15	001378
1000 S Lg-22	100	36,5	44	16	001385
1000 S Lg-24	100	39,5	44	17	001392
1000 S Lg-27	100	43,5	44	19	001408
1000 S Lg-28	100	45,5	44	19	001415
1000 S Lg-30	100	47,5	44	21	001422
1000 S Lg-32	100	50,0	44	21	001439
1000 S Lg-33	100	51,5	44	21	001446
1000 S Lg-34	100	52,5	44	22	001453
1000 S Lg-36	100	55,0	44	23	001460



- Long style
e.g. for deeply located wheel nuts/bolts on commercial vehicles
- For impact operation
- □ drive 20 = 3/4"

HAZET No.	l mm	d ₁ mm	d ₂ mm	t mm	EAN-No. 4000896+
1004 S-24	400	44	38	25	055807
1004 S-27	400	44	42	28	055760
1004 S-30	400	44	46	29	055777
1004 S-32	400	44	48	33,5	055784
1004 S-33	400	44	50	33,5	055791
1004 S-36	400	44	53	35,5	055814

Extensions



- For impact operation
- □ drive 20 = 3/4"

HAZET No.	l mm	EAN-No. 4000896+
1005 S-7	175	001774
1005 S-10	250	001750
1005 S-13	330	001767

Universal Joint



- For impact operation
- □ drive 20 = 3/4"

HAZET No.	l mm	EAN-No. 4000896+
1006 S	99	001781

Adapters



- For impact operation
- □ drive 20 = 3/4"

HAZET No.	l mm	EAN-No. 4000896+
■ drive 12.5 = 1/2"		
1007 S-1	56	001804
■ drive 25 = 1"		
1007 S-2	65	001828

6-Point Sockets



- Suitable for all types of electric and pneumatic screw driving machines (**screwdrivers and impact wrenches**)
- For excessive use
- □ drive 25 = 1"
- Chrome-Vanadium special steel
- Surface burnished
- DIN 3129, ISO 2725-2
- * = not according to DIN

HAZET No.	l mm	d ₁ mm	d ₂ mm	t min. mm	EAN-No. 4000896+
1100 S-24	58	41,5	54	17	002207
1100 S-27	60	45,0	54	19	002214
1100 S-30	62	49,0	54	21	002221
1100 S-32	63	51,5	54	21	002238
1100 S-33*	63	52,5	54	21	002252
1100 S-34	63	53,5	54	22	002269
1100 S-36	67	56,5	54	23	002276
1100 S-38*	70	59,0	54	24	002283
1100 S-41	70	63,0	54	26	002290
1100 S-42*	73	64,5	54	28	002313
1100 S-46	76	69,5	54	28	002320
1100 S-50	82	74,5	54	30	002344
1100 S-55	87	81,0	54	32	002351
1100 S-60	91	87,0	54	34	002375



- Long style
- For impact operation
- □ drive 25 = 1"

HAZET No.	l mm	d ₁ mm	d ₂ mm	t min. mm	EAN-No. 4000896+
1100 S Lg-24	110	41,5	54	17	002405
1100 S Lg-27	110	45,0	54	19	002412
1100 S Lg-30	110	49,0	54	21	002429
1100 S Lg-32	110	51,5	54	21	002436
1100 S Lg-33	110	52,5	54	21	002443
1100 S Lg-34	110	53,5	54	22	002450
1100 S Lg-36	110	56,5	54	23	002467
1100 S Lg-38	110	59,0	54	24	002474
1100 S Lg-41	110	63,0	54	26	002481
1100 S Lg-46	110	69,5	54	28	002498

6-Point Sockets



- Especially long style
e.g. for deeply located wheel nuts/bolts on commercial vehicles
- For impact operation
- □ drive 25 = 1"

HAZET No.	l mm	d ₁ mm	d ₂ mm	t mm	EAN-No. 4000896+
1104 S-32	270	51,5	54	32	002665

Extensions



- For impact operation
- □ drive 25 = 1"

HAZET No.	l mm	EAN-No. 4000896+
1105 S- 7	180	002702
1105 S-13	330	002696

Universal Joint



- For impact operation
- □ drive 25 = 1"

HAZET No.	l mm	EAN-No. 4000896+
1106 S	125	002719

Adapters



- drive 25 = 1"
- drive 20 = 3/4"

HAZET No.	l mm	EAN-No. 4000896+
1107 S	70	002733

Rubber Rings (O) and Steel Pins (-)



DIN 3129, ISO 2725-2

HAZET No.	mm	EAN-No. 4000896+
for all □ connections 6.3 = 1/4"		
850 S-G 414	∅ 1,9 x 2,5	037995
850 S-H 414	∅ 1,5 x 10	038008

HAZET No.	mm	EAN-No. 4000896+
for sockets □ drive 10 = 3/8"		
6-12 mm, E 5-E 14		
880 S-G 612	∅ 13 x 3,5	041381

HAZET No.	mm	EAN-No. 4000896+
for sockets □ drive 10 = 3/8"		
13-19 mm, extensions, universal joints, adapters		
880 S-G 1317	∅ 16 x 3,5	041374

HAZET No.	mm	EAN-No. 4000896+
for sockets □ drive 10 = 3/8"		
6-12 mm, E 5-E 14		
880 S-H 612	∅ 2,5 x 14	041404

HAZET No.	mm	EAN-No. 4000896+
for sockets □ drive 10 = 3/8"		
13-19 mm, extensions, universal joints, adapters		
880 S-H 1317	∅ 2,5 x 16	041398

Safety Springs



for impact sockets according to DIN 3129

HAZET No.	mm	EAN-No. 4000896+
for sockets □ drive 10 = 3/8"		
6-12 mm, E 5-E 14		
880 S-HF 612	∅ 16,6	041428

HAZET No.	mm	EAN-No. 4000896+
for sockets □ drive 10 = 3/8"		
13-19 mm extensions, universal joints, adapters		
880 S-HF 1319	∅ 18,0	041411

Rubber Rings (O) and Steel Pins (-)



12.5 1/2"

HAZET No.	mm	EAN-No. 4000896+
-----------	----	------------------

for sockets □ drive 12.5 = 1/2"
8-14 mm, 13 mm long style,
E 10-E 16, T 30-T 60

900 S-G 1014	∅ 19 x 4	044689
--------------	----------	--------

for sockets □ drive 12.5 = 1/2"
15-27 mm, 16-27 mm long style,
E 18-E 24,
extensions, universal joints, adapters

900 S-G 1527	∅ 24 x 4	044696
--------------	----------	--------

for sockets □ drive 12.5 = 1/2"
8-14 mm, 13 mm long style,
E 10-E 16, T 30-T 60

900 S-H 1014	∅ 3 x 20	044702
--------------	----------	--------

for sockets □ drive 12.5 = 1/2"
15-27 mm, 16-27 mm long style,
E 18-E 24,
extensions, universal joints, adapters

900 S-H 1527	∅ 3 x 26	044719
--------------	----------	--------

Safety Springs



12.5 1/2"

for impact sockets according to DIN 3129

HAZET No.	mm	EAN-No. 4000896+
-----------	----	------------------

for sockets □ drive 12.5 = 1/2"
8-14 mm, E 10-E 16

900 S-HF 814	∅ 21	044733
--------------	------	--------

for sockets □ drive 12.5 = 1/2"
15-27 mm, E 18-24,
extensions, universal joints, adapters

900 S-HF 1530	∅ 25	044726
---------------	------	--------

Rubber Rings (O) and Steel Pins (-)



20 3/4"

HAZET No.	mm	EAN-No. 4000896+
-----------	----	------------------

for all □ connections 20 = 3/4"

1000 S-G 1736	∅ 36 x 5	001354
---------------	----------	--------

1000 S-H 1736	∅ 4 x 36	001361
---------------	----------	--------

25 1"

HAZET No.	mm	EAN-No. 4000896+
-----------	----	------------------

for all □ connections 25 = 1"

1100 S-G 2260	∅ 45 x 7	002382
---------------	----------	--------

1100 S-H 2260	∅ 5 x 45	002399
---------------	----------	--------

Tool Cases



Tool Cases

- Practical and exclusive "Slim-Line" case (only 105 mm high) made of plastic
- For universal application e.g. for hobby, house and garden
- Clear and safe tool arrangement in high-quality two coloured soft foam inserts – missing tools are noticed immediately
- Thanks to the clamping effect of the inserts the tools do not fall out
- Covered compartment for small parts
- 56 parts:

contents:
450 N-6x 7 8x9 10x11 12x13
14x15 16x17 18x19 21x22

760 N-2
801-40 55 65
801-PH 1 PH 2 801-PZ 2
839-1

880-8 10 11 12 13 14 15
16 17 18 19 20 21 22

8816 P 8821-3 6
1803-22 1979-40 1981
2100-02 03 04 05 06 07 08
2115-T 8 T10 T15 T20 T25 T30 T40
2140-5 2154-2
2157 2158

HAZET No.	EAN-No. 4000896+
1520/56	111183

Tool Sets



(E)

- Metric sizes
- In sheet metal box
- With plastic insert
- 49 parts

contents:
450 N-6x 7 8x 9 10x11 12x13
14x15 16x17 18x19 20x22
21x23 24x26 25x28 27x32

630-6x7 8x 9 10x11 12x13
14x15 16x17 18x19 20x22
21x23 24x26 25x28 27x32

900Z-10 11 12 13 14 15 16 17 18 19
20 21 22 23 24 26 27 28 30 32
915 916SP 917-5 918-10 920

HAZET No.	EAN-No. 4000896+
1530 M/49	003525



(E)

- American sizes
- In sheet metal box
- With plastic insert
- 38 parts

contents:
450 NA-1/4 x 5/16 3/8 x 7/16 1/2 x 9/16
19/32 x 11/16 5/8 x 3/4 25/32 x 7/8 15/16 x 1
630 A- 1/4 x 5/16 3/8 x 7/16 1/2 x 9/16 19/32 x 11/16
1/4 x 25/32 13/16 x 7/8 15/16 x 1 1 1/16 x 1 1/8
900 AZ- 3/8 7/16 1/2 9/16 19/32 5/8
1 1/16 3/4 25/32 13/16 7/8 15/16
3 1/32 1 1 1/16 1 1/8 1 3/16 1 1/4

915 916SP 917-5
918-10 920

HAZET No.	EAN-No. 4000896+
1530 A/38	003518

TORX® Screw Driving Sets



435 x 215 x 82

- □ drive 6.3 = 1/4" and 12.5 = 1/2"
- Common tools for inside and outside TORX® screws
- In sheet metal box
- With plastic insert
- 64 parts

contents:
609-E 6xE 8 E10xE12
E14xE18 E20xE24
803-T 6 T 8 T10 T15
T20 T25 T30
850-E4 E5 E6 E8 E10
850S-E4 E5 E6 E8 E10
900-E10 E12 E14 E18
E20 E24
900S-E10 E12 E14 E18
E20 E24
992-T40 T45 T50 T55 T60
995S-T30 T40 T50 T55 T60
2115-T 8 T10 T15 T20 T25 T27
T30 T45 T50 T55 T60
2223-T 8 T 9 T10 T15
T20 T25 T30
2224-T40 T45 T50

HAZET No.	EAN-No. 4000896+
1555/64	003679

TORX® Screw Driving Sets



225 x 123 x 46

- □ drive 12.5 = 1/2"
- For inside and outside TORX® screws
- In sheet metal box
- With plastic insert
- 9 parts

Inhalt:
900-E10 E12 E14 E16
992-T30 T40 T45 T50 T55

HAZET No.	EAN-No. 4000896+
1557 N/9	076444

TORX® Screw Driving Sets



157 x 97 x 37

- drive 6.3 = 1/4", 10 = 3/8" and 12.5 = 1/2"
- For outside TORX® screws
- In plastic box
- With PUR foam insert
- 9 parts

contents:
850-E 4 E 5 E 6
880-E 8 E10 E12
900-E14 E18 E20

HAZET No.	EAN-No. 4000896+
1557/9	003907

TORX® Screw Driving Sets



225 x 123 x 48

- For inside and outside TORX® screws
- Esp. for FORD
- In sheet metal box
- With plastic insert
- 17 parts

contents:
609-E10 x E12 803-T20 T25
900-E12
992- T40 T45 T50 T55
2115-T20 T25 T30 T40
2223-T20 T25 T30 T40
2250-1

HAZET No.	EAN-No. 4000896+
1557 N/17	003945

TORX® Screw Driving Sets



320 x 128 x 44

- For inside and outside TORX® screws
- Esp. for gas stations and workshops
- In sheet metal box
- With plastic insert
- 22 parts

contents:
609-E10 x E12
803-T25 T27 T30
850-E6 E8
880-E10 E12 E14
992-T27 T30 T40 T45 T50 T55
2115-T9 T10 T20 T25 T30 T45 T50

HAZET No.	EAN-No. 4000896+
1557 N/22	003969



167 x 97 x 37

- drive 6.3 = 1/4", 10 = 3/8" and 12.5 = 1/2"
- For inside TORX® screws
- 10 parts

contents:
8502-T 8 T10 T15
8802-T20 T25 T30
992- T40 T50 T55 T60

HAZET No.	EAN-No. 4000896+
1557/10	003716



225 x 123 x 48

- For inside and outside TORX® screws
- Esp. for OPEL
- In sheet metal box
- With plastic insert
- 20 parts

contents:
850-E8
880-S-E 6 E8 E10 E12
900-S-E14
2223-T 7 T 8 T 9 T10 T15
T20 T25 T27 T30
2224-T40 T45 T50 2230-S-1 3

HAZET No.	EAN-No. 4000896+
1557/20	003785



270 x 121 x 47

- For inside and outside TORX® screws
- In plastic box
- With PUR foam insert
- 29 parts

contents:
609-E 6 x E 8 E10 x E12
E14 x E18 E20 x E24
850-E5 E6 E7 E8
880-E10 E12 E14
900-E10 E12 E14
992-T55 T60
2223-T10 T20 T25 T27 T30
2223-T30 H 2223-Lg-T25
2224-T40 T45 T50
2250-1 3 5

HAZET No.	EAN-No. 4000896+
1557/29	003846



225 x 123 x 48

- For inside TORX® screws
- Esp. for RENAULT commercial vehicles
- In sheet metal box
- With plastic insert
- 15 parts

contents:
8815 8858-2
2223-T 6 T 7 T 8 T 9 T10 T15
T20 T25 T27 T30 T40
2250-1 2255

HAZET No.	EAN-No. 4000896+
1557/15	003761



344 x 188 x 58

- For inside and outside TORX® screws
- In plastic box
- With PUR foam insert
- 21 parts

contents:
880-E 5 E 6 E 7 E 8
E10 E11 E12 E14
8802-T15 T20 T25 T27
T30 T40 T45 T50
8815 8816P 8820 8821-3 6

HAZET No.	EAN-No. 4000896+
1557/21	003822



177 x 125 x 38

- With Bits, 2 pieces each
- For inside TORX® screws
- In black plastic box
- With PUR foam insert
- 32 parts

contents:
2223-T 6 T 7 T 8 T 9 T10
T15 T20 T25 T27 T30 à 2
2224-T40 T45 T50 T55 à 2
2250-1 2 3 5

HAZET No.	EAN-No. 4000896+
1557/32	003860

TORX® Screw Driving Sets



410 x 216 x 65

- For inside and outside TORX® screws
- In plastic box
- With PUR foam insert

TORX® Screw Driving Sets



- 58 parts
- contents:
 - 609-E6 x E8 E10 x E12 E14 x E18 E20 x E24
 - 803-T 6 T 7 T 8 T 9 T10
 - T15 T20 T25 T27 T30
 - 850-E 4 E 5 E 6 E 7 E8
 - 880-E10 E11 E12 E14
 - 8802-T 40 T45
 - 900-E16 E18 E20 E24
 - 992-T50 T55 T60
 - 2115-T 6 T 7 T 8 T 9 T10 T15
 - T20 T25 T27 T30 T40
 - 2223-T6
 - 2223-T 7H T 8H T 9H T10H
 - T15H T20H T25H T27H
 - T30H T40H
 - 2223 Lg-T25
 - 2250-1 2 2264

HAZET No.	EAN-No. 4000896+
1557/58	003884

TORX® Selector



- For measuring the sizes of inside and outside TORX® screws, even in areas with restricted access
- With bore hole, therefore also suitable for tamper TORX® screws (inside TORX® screws with pin)
- Sizes T 10 up to T 60 resp. E 6 up to E 16

HAZET No.	EAN-No. 4000896+
1557 TS-1	062430

Ply our All-rounders on any Occasion

✓ *Special steel for excessive use*

✓ *Induction hardened cutting edges*

✓ *Ergonomically shaped handles*

✓ *Top quality for a long durability*

Heavy-Duty Diagonal Cutters



- Performance class H (piano wire, hardened steel wire)
- Lay-on joint – American model
- Chrome-Vanadium
- Surface bright chrome-plated
- DIN ISO 5749

o = not according to DIN
+ = with ergonomic plastic handle covers

HAZET No.	l mm	Rm N/mm ² ○ 800 ● 1600 ● 2300	EAN-No. 4000896+
1802-1 o	160	3,5 2,5 2,0	006021
1802-2 o	180	3,8 2,7 2,2	006045
1802-3	200	4,2 3,0 2,5	006069
1802-11 +	160	3,8 2,5 2,0	006038
1802-22 +	180	3,5 2,5 2,0	006052
1802-33 +	200	4,2 3,0 2,5	006076



- Performance class H (piano wire, hardened steel wire)
- Lay-on joint – American model
- Handles with dip coating
- Chrome-Vanadium
- DIN ISO 5749

Heavy-Duty Diagonal Cutters

HAZET No.	l mm	Rm N/mm ² ○ 800 ● 1600 ● 2300	EAN-No. 4000896+
1802 N-1	160	3,5 2,5 2,0	086238
1802 N-2	180	3,8 2,7 2,2	086245
1802 N-3	200	4,2 3,0 2,5	086252

VDE Heavy-Duty Diagonal Cutters



- Protected according to IEC 900, DIN EN 60900 VDE 0680/part 2
- Performance class H (piano wire, hardened steel wire)
- Lay-on joint – American model
- Ergonomic plastic handle covers, red, handles are directly injected onto the pliers' shanks, increasing the durability and cohesiveness. No twisting or pulling-off of the handles.
- Chrome-Vanadium
- Surface bright chrome-plated
- DIN ISO 5749

* = not according to DIN

HAZET No.	l mm	Rm N/mm ² ○ 800 ● 1600 ● 2300	EAN-No. 4000896+
1802 VDE-22 *	180	3,8 2,7 2,2	086382
1802 VDE-33	200	4,2 3,0 2,5	086399

Diagonal Cutters



- Performance class H (piano wire, hardened steel wire)
- Lap-joint – Swedish model
- With ergonomic plastic handle covers
- Special steel
- Surface bright chrome-plated
- DIN ISO 5749

HAZET No.	l mm	Rm N/mm ² ○ 800 ● 1600 ● 2300	EAN-No. 4000896+
1803-11	145	2,5 1,8 -	006090
1803-22	165	2,8 2,0 -	006106
1803-33	180	3,0 2,5 -	006120



- For steel wire, hard wire
- Lap-joint – Swedish model
- Handles with dip coating
- DIN ISO 5749

HAZET No.	l mm	Rm N/mm ² ○ 800 ● 1600 ● 2300	EAN-No. 4000896+
1803 N-2	160	2,8 2,0 -	086269

VDE-Diagonal Cutters



- Protected according to IEC 900, DIN EN 60900 VDE 0680/part 2
- For steel wire, hard wire
- Lap joint – Swedish model
- Ergonomic plastic handle covers, red, handles are directly injected onto the pliers' shanks, increasing the durability and cohesiveness. No twisting or pulling-off of the handles.
- Chrome-Vanadium
- Surface bright chrome-plated
- DIN ISO 5749

HAZET No.	l mm	Rm N/mm ² ○ 800 ● 1600 ● 2300	EAN-No. 4000896+
1803 VDE-22	160	2,8 2,5 -	006137

High-Leverage Diagonal Cutters



- Performance class H (piano wire, hardened steel wire)
- Leverage **reduces force expenditure by 40%**
- With opening spring
- Handles with dip coating
- DIN ISO 5747

HAZET No.	l mm	Rm N/mm ² ○ 800 ● 1600 ● 2300	EAN-No. 4000896+
1804 N-2	160	3,0 2,7 2,2	086276

High-Leverage End Cutters



- Performance class H (piano wire, hardened steel wire)
- DIN ISO 5748

HAZET No.	l mm	Ø mm	EAN-No. 4000896+
1806-3	208	2,5	006199
1806-4	230	3,0	006205

Heavy-Duty End Cutting Pliers



- Performance class H (piano wire, hardened steel wire)
- With plastic handle covers
- Surface bright chrome-plated
- DIN ISO 5748

HAZET No.	l mm	Ø mm	EAN-No. 4000896+
1807-11	170	1,6	006229



- Performance class H (piano wire, hardened steel wire)
- Lay-on joint – American model
- Handles with dip coating
- Chrome-Vanadium
- DIN ISO 5748

HAZET No.	l mm	Ø mm	EAN-No. 4000896+
1807 N-1	160	2,2	086283

End Cutting Pliers



- (Tower Pincers)
- For e.g. car body work
- DIN ISO 9242

HAZET No.	l mm	EAN-No. 4000896+
1810-250	250	006236

Wire Twisters



- **For screw retention** e.g. for the aerospace and motor sport sector
- Right-hand drive
- Bevelled at 30°
- For wires up to 1.6 mm Ø
- With side cutter and serrated jaws
- Special Steel (all-metal construction)
- Head polished

HAZET No.	l mm	EAN-No. 4000896+
1811-205	205	078929
1811-250	250	078936

Connector Pliers



- **For loosening and tightening plug adapters, e.g. Canon connectors**
- For careful operation of light alloy screwings and tube fittings without damaging the surface
- Replaceable plastic jaws
- 4-position slip joint
- Handles with plastic coating
- Chrome-Vanadium
- Surface chrome-plated

HAZET No.	EAN-No. 4000896+
1815-230	078943
Spare plastic jaws (pair)	
1815-01/2	079643

Long Flat Nose Pliers



- Ergonomic plastic handle covers
- Special steel
- Surface bright chrome-plated
- Functional dimensions according to DIN ISO 5745

HAZET No.	l mm	EAN-No. 4000896+
1816-22	162	006274



- With long jaws
- Handles with dip coating
- DIN ISO 5745

HAZET No.	l mm	EAN-No. 4000896+
1816 N-2	160	086290

VDE Flat Nose Pliers



- Protected according to IEC 900, DIN EN 60900 VDE 0680/part 2
- Ergonomic plastic handle covers, red, handles are directly injected onto the pliers' shanks, increasing the durability and cohesiveness. No twisting or pulling-off of the handles.
- With long jaws
- Chrome-Vanadium
- Surface bright chrome-plated
- DIN ISO 5745

HAZET No.	l mm	EAN-No. 4000896+
1816 VDE-22	160	006298

Long Round Nose Pliers



- Ergonomic plastic handle covers
- Special steel
- Surface bright chrome-plated
- DIN ISO 5745

HAZET No.	l mm	EAN-No. 4000896+
1826-22	168	006311



- With long jaws
- Handles with dip coating
- DIN ISO 5745

HAZET No.	l mm	EAN-No. 4000896+
1826 N-2	160	086306

VDE Round Nose Pliers



- Protected according to IEC 900, DIN EN 60900 VDE 0680/part 2
- Ergonomic plastic handle covers, red, handles are directly injected onto the pliers' shanks, increasing the durability and cohesiveness. No twisting or pulling-off of the handles.
- With long jaws
- Chrome-Vanadium
- Surface bright chrome-plated
- DIN ISO 5745

HAZET No.	l mm	EAN-No. 4000896+
1826 VDE-22	160	006328

Snipe Nose Pliers



- Chain nose side cutting pliers
- Slim design
- Straight jaws
- With groove and cutter for hard wire
- Special steel
- Surface bright chrome-plated
- DIN ISO 5745

HAZET No.	l mm	EAN-No. 4000896+
1841 a-2	160	006359
1841 a-3	200	006373

Snipe Nose Pliers



- Ergonomic plastic handle covers
- Special steel
- Surface bright chrome-plated
- DIN ISO 5745

HAZET No.	l mm	EAN-No. 4000896+
1841 a-11	145	006342
1841 a-22	163	006366
1841 a-33	205	006380



- Straight design
- Handles with dip coating
- DIN ISO 5745

HAZET No.	l mm	EAN-No. 4000896+
1841 N a-3	200	086313

VDE Snipe Nose Pliers



- Protected according to IEC 900, DIN EN 60900 VDE 0680/part 2
- Ergonomic plastic handle covers, red, handles are directly injected onto the pliers' shanks, increasing the durability and cohesiveness. No twisting or pulling-off of the handles.
- Straight design
- Chrome-Vanadium
- Surface bright chrome-plated
- DIN ISO 5745

HAZET No.	l mm	EAN-No. 4000896+
1841 a VDE-22	160	006397
1841 a VDE-33	200	006403

Snipe Nose Pliers



- Curved jaws (45°)
- Special steel
- Surface bright chrome-plated
- DIN ISO 5745

HAZET No.	l mm	EAN-No. 4000896+
1841 b-33	195	006434



- Curved jaws (45°)
- Special steel
- Surface bright chrome-plated
- DIN ISO 5745

HAZET No.	l mm	EAN-No. 4000896+
1841 b-3	195	006427



- Curved jaws (45°)
- Handles with dip coating
- DIN ISO 5745

HAZET No.	l mm	EAN-No. 4000896+
1841 N b-3	200	086320

VDE Snipe Nose Pliers



- Protected according to IEC 900, DIN EN 60900 VDE 0680/part 2
- Ergonomic plastic handle covers, red, handles are directly injected onto the pliers' shanks, increasing the durability and cohesiveness. No twisting or pulling-off of the handles.
- Curved jaws (45°)
- Chrome-Vanadium
- Surface bright chrome-plated
- DIN ISO 5745

HAZET No.	l mm	EAN-No. 4000896+
1841 b VDE-33	200	006441

Snipe Nose Pliers



- Bent jaws (90°)
- Slim design
- Ergonomic plastic handle covers
- Special steel
- Surface bright chrome-plated

HAZET No.	l mm	EAN-No. 4000896+
1841 c-33	188	006465

Long Flat Nose Pliers



- **Extra long style**
- Especially for areas with restricted access
- Special steel
- Handles with dip coating

HAZET No.	l mm	EAN-No. 4000896+
-----------	------	------------------

Straight design

1841 A-280	280	051489
------------	-----	--------

Curved jaws (45°)

1841 B-280	280	051694
------------	-----	--------

Snipe Nose Pliers



- **For installing and removing the fuel overflow line (overflow oil line)** without damaging the overflow pipe
- For deeply located injection nozzles on diesel engines, e.g. MERCEDES-BENZ 604, 605, 606 with 4-valve technique
- For the operation of circlips on fuel lines (injection nozzles / injection pump) in areas with restricted access, esp. on MERCEDES-BENZ 604, 605 and 606
- For the replacement of the valve reeds on BMW motorcycles with 2-valve technique K 75 and K 100
- Ergonomic handle covers

HAZET No.	l mm	EAN-No. 4000896+
1841-33	205	083916

Multipurpose Pliers



- Flat Nose Pliers, Wire Stripper and Crimping Tool
- Handles with dip coating

HAZET No.	l mm	EAN-No. 4000896+
1842 N-1	160	086337

Lockring Pliers



- Safe and easy working due to precise, conical and relief-ground jaws
- Various types of plier tips allow universal application
- Solid plastic body
 - the metal core extends far into the pliers' shanks
 - light-weight
 - ergonomically formed
- With readjusting spring
- Twist-safe, tips are welded to the solid metal core
- **Straight design, form A**
- For outside lockrings (shafts)
- DIN 5254
- Protected by design patent, EP

HAZET No.	l mm	Ø mm	EAN-No. 4000896+
1845 A- 3	143	0,9	048663
1845 A-10	140	1,3	048670
1845 A-19	180	1,8	048687



- **Bent jaws (90°), form B**
- For outside lockrings (shafts)

HAZET No.	l mm	Ø mm	EAN-No. 4000896+
1845 B- 3	130	0,9	048694
1845 B-10	130	1,3	048700
1845 B-19	172	1,8	048717



- **Straight design, form C**
- For inside lockrings (bore holes)
- DIN 5256
- Protected by design patent, EP

HAZET No.	l mm	Ø mm	EAN-No. 4000896+
1845 C- 8	140	0,9	048724
1845 C-12	140	1,3	048731
1845 C-19	180	1,8	048748

Lockring Pliers



- Bent jaws (90°), form D
- For inside lockrings (bore holes)

HAZET No.	l mm	Ø mm	EAN-No. 4000896+
1845 D- 8	133	0,9	048755
1845 D-12	133	1,3	048762
1845 D-19	170	1,8	048779



- Curved jaws (45°)
- For outside lockrings (shafts)
- DIN 5254

HAZET No.	l mm	Ø mm	EAN-No. 4000896+
1845 E- 3	140	0,9	048786
1845 E-10	140	1,3	048793
1845 E-19	180	1,8	048809



- Curved jaws (45°)
- For inside lockrings (bore holes)
- DIN 5256

HAZET No.	l mm	Ø mm	EAN-No. 4000896+
1845 F- 8	140	0,9	048816
1845 F-12	140	1,3	048823
1845 F-19	180	1,8	048830

Lockring Pliers Set



Set with 8 parts

contents:
1845 A-10 19 1845 B-10 19
1845 C- 8 19 1845 D- 8 19

HAZET No.	EAN-No. 4000896+
1845/8	048656

Lockring Pliers



- Cylindrical tips worked out in optimal angle
- Exactly defined cone tips
- Safe fit of the lockrings, free from play
- Electrothermic hardening and tempering
- Chrome-Vanadium
- Surface bright chrome-plated, tips steel grey
- Straight design
- For inside lockrings (bore holes)
- DIN 5256 form C

Lockring Pliers

* = not according to DIN

HAZET No.	l mm	Ø mm	EAN-No. 4000896+
1846 a-0	139	0,9	006793
1846 a-1 *	140	1,3	006809
1846 a-2	180	1,8	006816
1846 a-3	225	2,3	006823
1846 a-4 *	310	3,2	006830



- For application on commercial vehicles, building and agricultural machinery
- Toothed rack locks Lockring Pliers and facilitates installing and removing of circlips
- Lever to release toothed rack
- Handles made of sheet steel
- Replaceable tips hardened and tempered
- Surface powder-coated

HAZET No.	l mm	Ø mm	DIN 471 993 mm	EAN-No. 4000896+
straight jaws for inside lockrings (bore holes)				
1846 a-5	545	3,5	122-300	081271

Replacement tips, straight for 1846 a-5				
1846 a-05/2	-	3,5	-	081288

Conversion tips, bent 90°, to convert the Pliers 1846 a-5				
1846 b-05/2	-	3,5	-	081318

straight jaws for inside lockrings (bore holes)				
1846 a-6	545	4,5	252-400	081295

Replacement tips, straight for 1846 a-6				
1846 a-06/2	-	4,5	-	081301

Conversion tips, bent 90°, to convert the Pliers 1846 a-6				
1846 b-06/2	-	4,5	-	081325



- For inside lockrings (bore holes)
- Bent jaws (90°)
- Chrome-Vanadium
- Surface chrome-plated, tips steel grey
- DIN 5256 form D

* = not according to DIN

HAZET No.	l mm	Ø mm	EAN-No. 4000896+
1846 b-0	139	0,9	006847
1846 b-1 *	140	1,3	006854
1846 b-2	180	1,8	006861
1846 b-3	225	2,3	006878
1846 b-4	310	3,2	006885



- For deeply located lockrings e.g. on callipers and gearboxes
- With long jaws, bent (90°)
- Solid plastic handles with anti-slipping device
- Chrome-Vanadium
- Surface chrome-plated

HAZET No.	l mm	Ø mm	EAN-No. 4000896+
1846 b-1,6	195	1,6	061457

Lockring Pliers



- For outside lockrings (shafts)
- Straight design
- Chrome-Vanadium
- Surface bright chrome-plated, tips steel grey
- DIN 5254 form A

HAZET No.	l mm	Ø mm	EAN-No. 4000896+
1846 c-0	139	0,9	006892
1846 c-1	140	1,3	006908
1846 c-2	180	1,8	006915
1846 c-3	225	2,3	006922
1846 c-4	310	3,2	006939



- For application on commercial vehicles, building and agricultural machinery
- Toothed rack locks Lockring Pliers and facilitates installing and removing of circlips
- Lever to release toothed rack
- Handles made of sheet steel
- Replaceable tips hardened and tempered
- Surface powder-coated

HAZET No.	l mm	Ø mm	DIN 471 993 mm	EAN-No. 4000896+
-----------	------	------	----------------	------------------

straight jaws for outside lockrings (shafts)				
1846 c-5	538	3,5	122-300	081332

Replacement tips, straight for 1846 c-5				
1846 c-05/2	-	3,5	-	081349

Conversion tips, bent 90°, to convert the Pliers 1846 c-5				
1846 d-05/2	-	3,5	-	081370

straight jaws for outside lockrings (shafts)				
1846 c-6	538	4,5	252-400	081356

Replacement tips, straight for 1846 c-6				
1846 c-06/2	-	4,5	-	081363

Conversion tips, bent 90°, to convert the Pliers 1846 c-6				
1846 d-06/2	-	4,5	-	081387



- For outside lockrings (shafts)
- Bent jaws (90°), form B
- Chrome-Vanadium
- Surface chrome-plated, tips steel grey
- DIN 5254 form B

* = not according to DIN

HAZET No.	l mm	Ø mm	EAN-No. 4000896+
1846 d-0	139	0,9	006946
1846 d-1	140	1,3	006953
1846 d-2 *	180	1,8	006960
1846 d-3	225	2,3	006977
1846 d-4	310	3,2	006984

Clamp Pliers



- For installing **axle collars made of Hytrel** and clamps made of special steel with pre-set **torque values**, in conjunction with e.g. Torque Wrench HAZET 6110-1 CT
- For VW-AUDI, OPEL, FORD, etc.
- Special steel

HAZET No.	l mm	EAN-No. 4000896+
1847	178	050918

Clamp Pliers



- For **axle collar clamps** on passenger cars, e.g. on VW-AUDI, OPEL, BMW, MERCEDES-BENZ, HONDA, NISSAN, MAZDA
- With lug holding-down device
- Special steel
- Surface nickel-plated

HAZET No.	l mm	EAN-No. 4000896+
1847-1	230	007004

Lockring Pliers



- For **outside lockrings** (shafts) e.g. on gearboxes
- **Bent tips (90°)**
- Chrome-Vanadium
- Surface chrome-plated

HAZET No.	l mm	EAN-No. 4000896+
1847-2	200	007011



- For **outside lockrings** (shafts) on VW-AUDI, e.g. outside homocinetic joint
- **Straight tips**
- Chrome-Vanadium
- Surface chrome-plated

HAZET No.	l mm	EAN-No. 4000896+
1847-3	200	007028



Lockring Pliers

- For **circlips** e.g. on **cardan shafts and gearboxes** especially for VW
- Esp. for Golf: exterior cardan/bearing shafts and transmission shaft rings of the cardan T 4: flanged shaft
AUDI 80: exterior cardan/bearing shafts
- **Bent tips (30°)**
- Chrome-Vanadium
- Surface chrome-plated

HAZET No.	l mm	EAN-No. 4000896+
1847-6	200	050468

Clamp Pliers



- For **circlips on cardan shafts and gearboxes**
- Esp. on VW e.g. VW T4 and T2
- **Bent tips (30°)**
- Chrome-Vanadium
- Surface chrome-plated

HAZET No.	l mm	EAN-No. 4000896+
1847-61	200	058761



- For **circlips in pressure plates/thrust bearings** of IVECO gears
- For Daily and Eurocarg
- Chrome-Vanadium
- Surface chrome-plated

HAZET No.	l mm	EAN-No. 4000896+
1847-9	265	050086

Pliers for Axle Collar Clamps



- For **endless hose clamps** on axle collars, e.g. on FIAT, NISSAN, RENAULT
- **With cutting device**

HAZET No.	l mm	EAN-No. 4000896+
1847-10	225	080342

Clamp Pliers



- For **progressively adjustable clamps without lug holding-down device** e.g. for axle collars on VW-AUDI, MERCEDES-BENZ and TOYOTA
- DBGM – German registered utility model

HAZET No.	l mm	EAN-No. 4000896+
1847-11	191	079520

Spark Plug Socket Pliers



- For installing and removing **spark plug sockets**
- Especially suitable for **hot terminals**
- With side cutter
- Ergonomic plastic handle covers
- Chrome-Vanadium
- Surface chrome-plated

HAZET No.	l mm	EAN-No. 4000896+
1849	195	007080



- For installing and removing straight **spark plug sockets**
- Safe application due to milled jaw profile
- Especially on MERCEDES-BENZ
- Ergonomic plastic handle covers
- Special steel
- Surface chrome-plated

HAZET No.	l mm	EAN-No. 4000896+
1849-1	200	007097



- For installing and removing straight **spark plug sockets**
- **Long jaws** provide a better safety distance to the hot engine
- Especially for **deeply located spark plug sockets** e.g. on AUDI V6 and V8 engines, JAGUAR 12-cyl.
- Ergonomic plastic handle covers
- Special steel
- Surface chrome-plated

HAZET No.	l mm	EAN-No. 4000896+
1849-2	290	007103



- For installing and removing **spark plug sockets**
- Especially suitable for **hot terminals**
- Long style
- Ergonomic plastic handle covers
- Special steel
- Surface chrome-plated

HAZET No.	l mm	EAN-No. 4000896+
1849-3	265	055098

Spark Plug Socket Remover



- For installing and removing **spark plug sockets** even on hot engines
- For 2.8-2.9 l VR6-engine VW-Golf, Passat, Vento, Corrado, AUDI 80, 100, A4, A6, with 2.4 and 2.8 l V6-engines
- Slotted tube for optimal and careful guidance of the cable
- Special steel

HAZET No.	l mm	EAN-No. 4000896+
1849-6	253	007110

Remover



- For installing and removing ignition coils with power stage on VW Polo, Golf 1,4, 1,6 l, Caddy 1,4 l, Bora 1,4, 1,6 l, Passat, Touran 1,6 l, Phaeton, Transporter T4
- With T-handle
- Chrome-Vanadium
- Surface chrome-plated

HAZET No.	EAN-No. 4000896+
1849-7	110353



- For removing and installing ignition coils with power stage of injection engines on 5 and 6 cyl. VW Golf, Bora, 4 and 5 cyl. VW Passat, 6 cyl. VW Sharan, Touareg, Phaeton
- With T-handle
- Chrome-Vanadium
- Surface chrome-plated

HAZET No.	EAN-No. 4000896+
1849-8	110360

Combination Pliers



- Induction hardened cutting edges
- Special steel
- Surface bright chrome-plated
- DIN ISO 5746

+ = with ergonomic plastic handle covers

HAZET No.	l mm	EAN-No. 4000896+
1850-2	165	007134
1850-3	180	007158
1850-22 +	170	007141
1850-33 +	190	007165
1850-44 +	210	007189



- Handles with dip coating
- Special steel
- DIN ISO 5746

HAZET No.	l mm	EAN-No. 4000896+
1850 N-2	160	086344
1850 N-3	180	086351
1850 N-4	200	086368

VDE Combination Pliers



- Protected according to IEC 900, DIN EN 60900 VDE 0680/part 2
- Ergonomic plastic handle covers, red, handles are directly injected onto the pliers' shanks, increasing the durability and cohesiveness. No twisting or pulling-off of the handles.
- DIN ISO 5746

HAZET No.	l mm	EAN-No. 4000896+
1850 VDE-22	160	007202
1850 VDE-33	180	007219
1850 VDE-44	200	007226

Heavy Duty Combination Pliers



- **Optimum leverage ratio** due to small distance between joint and cutting edges
- Induction hardened cutting edges
- Performance class H (piano wire, hardened steel wire)
- Special steel
- Surface chrome-plated bright heads
- DIN ISO 5746

HAZET No.	l mm	EAN-No. 4000896+
1851-44	210	055081

Wire Strippers



- For cables with a cross-section up to 6.0 mm²
- With adjusting screw and opening spring
- Handles with dip coating
- Special steel

HAZET No.	l mm	EAN-No. 4000896+
1860 N-1	160	086375

VDE Wire Strippers



- Protected according to IEC 900, DIN EN 60900 VDE 0680/part 2
- Ergonomic plastic handle covers, red, handles are directly injected onto the pliers' shanks, increasing the durability and cohesiveness. No twisting or pulling-off of the handles.
- For cables with a cross-section up to 6 mm²
- With adjusting screw and opening spring

HAZET No.	l mm	EAN-No. 4000896+
1860 VDE-11	160	007288

Automatic Wire Strippers



- For PVC covered solid and flexible cables, cross-section 0.5 up to 4.0 mm²
- Automatically adjusts to cross-section, easy application – perfect result
- Integrated side cutter for wire cutting
- Plastic housing

HAZET No.	l mm	EAN-No. 4000896+
1862	180	007301



- For wire stripping of electrical conductors, stranded conductors and cables
- For copper and aluminium conductors
- Stripping range PVC covered conductors, cross-section 0.2 up to 6 mm²
- Maximum stripping length 18 mm
- Spring-loaded knife-type blades
- Automatically adjusts to insulation thickness, easy application – perfect result
- With wire cutter for 4 mm² single-wired and 6 mm² fine-stranded conductors

HAZET No.	l mm	EAN-No. 4000896+
1863	205	007325



- For PVC-insulated solid and flexible conductors with a cross-section of 0.5 up to 6.0 mm²
- Optimal control due to side lead-in of the conductor as well as adjustable stop to ensure constant and precise stripping length
- Integrated side-cutter for copper wires up to 2.8 mm²
- Fibreglass reinforced polyamide

HAZET No.	l mm	EAN-No. 4000896+
1863-1	179,5	057399

Electronic Diagonal Cutters



- For **copper wire** \varnothing 0.5 – 2.0 mm
- Flush cutter
- Lay-on joint
- Spiral springs
- Ergonomic 2-compound handles
- Special steel
- DIN ISO 9654

HAZET No.	l mm	EAN-No. 4000896+
1870	112	007332

Electronic Diagonal Cutters



- For **hardened steel wire (piano wire)** up 0.6 mm ϕ
- Centre cutter
- Lay-on joint
- Spiral springs
- Ergonomic 2-compound handles
- Special steel

HAZET No.	l mm	EAN-No. 4000896+
1870 a	112	007349

Electronic End Cutting Pliers



- For **copper wire** ϕ 0.5 – 2.0 mm
- Flush cutter
- Lay-on joint
- Spiral springs
- Ergonomic 2-compound handles
- Special steel

HAZET No.	l mm	EAN-No. 4000896+
1871-1	125	086504

Electronic Flat Nose Pliers



- Flat section
- Lay-on joint
- Spiral springs
- Ergonomic 2-compound handles
- Special steel
- DIN ISO 9655

HAZET No.	l mm	EAN-No. 4000896+
1872	125	007363

Electronic Round Nose Pliers



- Round section
- Lay-on joint
- Spiral springs
- Ergonomic 2-compound handles
- Special steel
- DIN ISO 9655

HAZET No.	l mm	EAN-No. 4000896+
1873-1	125	086511

Electronic Snipe Nose Pliers



- Half-round section
- Lay-on joint
- Spiral springs
- Ergonomic 2-compound handles
- Special steel
- DIN ISO 9655

Electronic Snipe Nose Pliers



HAZET No.	l mm	EAN-No. 4000896+
1874	125	007370

Electronic Combination Pliers



- For **copper wire** ϕ 0.5 – 2.0 mm
- Flat section
- Lay-on joint
- Spiral springs
- Ergonomic 2-compound handles
- Special steel
- DIN ISO 8979

HAZET No.	l mm	EAN-No. 4000896+
1875-1	125	086528

Tool Assortments



- For **car body work**
- For Tool Trolley HAZET-*Assistent*
- 77 parts



contents:
 428-6 7 8 10 11 13
 600 N-8 9 10 11 12 13 14 15 17 19 22 24
 745 a-6 745-4 746-1 757-10 760 N-2 799-3
 801 K-55
 803-25 55 65 80 100
 803-PH1 PH2 PH3
 821
 900-10 11 12 13 15 17 19 22
 916 SP 917-5 918-10
 1810-250 1850-44
 1917 N 1919 N 1920 N 1921
 1922 1923 1927 1929-1
 1930 1931 1934
 1934-1 4 9 10
 1937 K 1940 1950
 1960-5 1961 L-2 1961 R-2 1965/5
 2130 2140-3 5
 2143 2150 2165-1 2

HAZET No.	EAN-No. 4000896+
0-1900/77	000241

Body and Fender Tool Assortments



(E)

- For **car body work**
- In metal box
- 6 parts

contents:

 1911 1917 N 1918 N
1935 1938 K 1940

HAZET No.	EAN-No. 4000896+
1900/6	007431



(E)

- For **car body work**
- In metal box
- 10 parts

contents:

 1911 1917 N 1919 N 1928 K
1930 1931 1934 1935
1938 K 1940

HAZET No.	EAN-No. 4000896+
1905/10 N	007448



- For **car body work**
- In metal box with 5 trays 190 L
- 35 parts

contents:

 745 a-4 6 746-2
757-10 760 N-2
801 K-55 803-25 55 80
803-PH1 PH2 PH3
803-PZ1 PZ2
821
1802-22
1917 N 1919 N
1923 1924-7
1928 K 1933
1934 N-1 2
1934-4 7 9 10
1940 1949-1 1960-5 1961 R-2
2130 2140-5 2150

HAZET No.	EAN-No. 4000896+
1910/35	007479

Hand Anvils (Dollies)



- Roof wedge-shaped
- Length 137 mm width 55 mm
- Special steel
- Surface mat black, polished

HAZET No.	EAN-No. 4000896+
1911	007486



- Hatchet-shaped
- 69 x 23 mm and 52 x 6 mm, height 140 mm
- Special steel

HAZET No.	EAN-No. 4000896+
1914	007493



- Daimler Stöckle
- 110 x 50 mm, height 50 mm
- Special steel

HAZET No.	EAN-No. 4000896+
1917 N	007509



- Wedge-shaped
- 110 x 63 mm
- Special steel

HAZET No.	EAN-No. 4000896+
1918 N	007516



- Toe-shaped
- 120 x 58 mm, height 20 mm
- Special steel

HAZET No.	EAN-No. 4000896+
1919 N	007523



- Universal
- 76 x 56 mm and 65 x 47 mm, height 60 mm
- Special steel

HAZET No.	EAN-No. 4000896+
1920 N	007530



- **All-sides ground**
- Heel-shaped, flat/halfround
- 84 x 62 mm, height 34 mm
- Special steel

HAZET No.	EAN-No. 4000896+
1921	007554

Hand Anvils (Dollies)



- "Diabolo" style
- 59 x 61 mm, height 59 mm
- Special steel

HAZET No.	EAN-No. 4000896+
1922	007561

Box File



- For body sheet planishing
- All sides with cut of a file
- 158 x 35 x 25 mm
- Special steel

HAZET No.	EAN-No. 4000896+
1923	007578

Caulking Irons



- With ball head 20 mm ϕ
- Special steel

HAZET No.	l mm	EAN-No. 4000896+
1924-1	290	007585



- With bevel head
- 70 x 10 mm
- Special steel

HAZET No.	l mm	EAN-No. 4000896+
1924-2	310	007592



- With lever section
- Offset, rounded
- 25 mm wide
- Special steel

HAZET No.	l mm	EAN-No. 4000896+
1924-3	325	007608



- With right-angle hook
- 12 mm wide, flat
- End rounded, 42 mm wide
- Special steel

HAZET No.	l mm	EAN-No. 4000896+
1924-4	310	007615



- Rounded, wedge-shaped
- 35 mm wide
- Special steel

HAZET No.	l mm	EAN-No. 4000896+
1924-5	260	007622



- Widely rounded, wedge-shaped
- 60 mm wide
- Special steel

HAZET No.	l mm	EAN-No. 4000896+
1924-6	230	007639

Caulking Irons



- Straight, wedge-shaped, eccentric
- 65 mm wide
- Special steel

HAZET No.	l mm	EAN-No. 4000896+
1924-7	330	007646



- Box-shaped
- 50 x 10 mm
- Special steel

HAZET No.	l mm	EAN-No. 4000896+
1924-8	165	007653



- Box-shaped
- 24 x 12 mm
- Special steel

HAZET No.	l mm	EAN-No. 4000896+
1924-9	130	007660

Hand Anvil (Dolly)



- 85 x 55 mm and 42 x 33 mm
- Special steel

HAZET No.	EAN-No. 4000896+
1925-1	007677

Pry and Bumping Spoon



- Blade size 110 x 200 x 40 mm
- Special steel
- Ground

HAZET No.	EAN-No. 4000896+
1926	007684

General Purpose Spoons



- Blade size 52 x 150 mm
- Special steel

HAZET No.	l mm	EAN-No. 4000896+
1927	275	007691



- Cut on one size
- Blade size 60 x 30 x 200 mm
- Special steel

HAZET No.	l mm	EAN-No. 4000896+
1928 K	385	007707

General Purpose Spoons



- Wide shape
- Offset and curved
- Blade size 170 x 50 mm
- Special steel

HAZET No.	l mm	EAN-No. 4000896+
1929-1	480	007721



- Wide shape
- Deep offset and heavily curved
- Special steel

HAZET No.	l mm	EAN-No. 4000896+
1930	455	007738



- Narrow shape
- Blade size 105 x 85 x 38 mm
- Special steel

HAZET No.	l mm	EAN-No. 4000896+
1930-1	315	007745

Bending Iron



- With leather cap
- Special steel

HAZET No.	l mm	EAN-No. 4000896+
1931	410	007769

Flange Tools



- Forms crimped edges on sheet metals up to 1 mm thickness
- Crimping capacity 12 mm
- Plastic handle covers
- Chrome-Vanadium
- Surface chrome-plated

HAZET No.	l mm	b mm	EAN-No. 4000896+
1932-1	300	15	007806
1932-2	300	30	007868



- Repair Set** consisting of:
1 pair of jaws, 15 mm wide,
2 screws and 2 sleeves
for 1932-1, -2, -5

1932-1/6	007820
----------	--------

- Repair Set** consisting of:
1 pair of jaws, 30 mm wide,
2 screws and 2 sleeves
for 1932-1, -2, -5

1932-2/6	007905
----------	--------

Flange Tools



- Forms crimped edges on sheet metals up to 1 mm thickness
- Crimping capacity 20 mm
- To be used with Countersinking Punch 1932-6, especially for body repairs, adhesive method
- Plastic handle covers
- Chrome-Vanadium
- Surface chrome-plated

HAZET No.	l mm	b mm	EAN-No. 4000896+
1932-5	300	15	007943



- Repair Set** consisting of:
1 pair of jaws, 15 mm wide,
2 screws and 2 sleeves
for 1932-1, -2, -5

1932-1/6	007820
----------	--------

- Repair Set** consisting of:
1 pair of jaws, 30 mm wide,
2 screws and 2 sleeves
for 1932-1, -2, -5

1932-2/6	007905
----------	--------

Countersinking Punch



- For countersinking pre-drilled rivet holes (countersunk rivets 4 mm dia.)
- To be used with Flange Tool HAZET 1932-5
- Plastic handle covers
- Chrome-Vanadium
- Surface chrome-plated

HAZET No.	l mm	EAN-No. 4000896+
1932-6	300	007967



- Repair Set** consisting of:
1 die, 1 pan and 2 headless screws for 1932-6

1932-6/4	007981
----------	--------

Seaming Pliers



- Bent off 45°
- Gap width 60 mm
- Chrome-Vanadium
- Surface chrome-plated

HAZET No.	l mm	EAN-No. 4000896+
1933	280	007998

Milled Tooth File with Holder



- Adjustable, with tightening screw
- One blade 1934-4 included
- Suitable for flat blades HAZET 1934-1 up to -5
- Special steel

HAZET No.	l mm	EAN-No. 4000896+
1934	355	008018

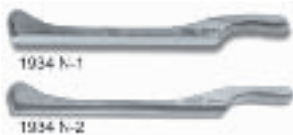

HAZET No.	l mm	EAN-No. 4000896+
-----------	------	------------------

- For flat file blades 1934-1 up to -5 (without blade)
- Wood

1934 N-1	525	008155
----------	-----	--------

- For half-round (hollow) file blades 1934-7 (without blade)
- Wood

1934 N-2	525	008179
----------	-----	--------

Milled Tooth File Blades



- Flat
- Milled, diagonal cut
- Teeth (cut):
 - 1 = coarse 1934-1
 - 2 = medium 1934-2
 - 3 = fine 1934-3
- For Files HAZET 1934 and 1934 N-1
- Chrome-alloyed special steel
- DIN 7264, form A

HAZET No.	l mm	EAN-No. 4000896+
1934-1	350	008025
1934-2	350	008063
1934-3	350	008070



- Flat
- Milled, curved cut
- Teeth (cut):
 - 1 = coarse 1934-4
 - 2 = medium 1934-5
- For Files HAZET 1934 and 1934 N-1
- Chrome-alloyed special steel
- DIN 7264, form A

HAZET No.	l mm	EAN-No. 4000896+
1934-4	350	008087
1934-5	350	008094



- Half-round (hollow)
- Diagonal cut
- Teeth (cut): 1 = coarse
- For files HAZET 1934 N-2
- Chrome-alloyed special steel
- DIN 7264, form F

HAZET No.	l mm	EAN-No. 4000896+
1934-7	350	008100

Milled Tooth Files



- Cross cut
- Teeth (cut):
 - 1 = coarse 1934-8
 - 3 = fine 1934-9
- Cranked
- Plastic handle
- Special steel

Heat the bent with a welding torch. Due to the special alloy, the heat is being extracted when working the metal with the file. The metal is planished.

HAZET No.	l ₁ mm	l ₂ mm	EAN-No. 4000896+
-----------	-------------------	-------------------	------------------

1934-8	350	430	008124
1934-9	350	430	008131

- Single cut
- Teeth (cut):
 - 0 = coarse 1934-10

1934-10	350	430	008032
---------	-----	-----	--------

Body Hammers



- Special steel
- HICKORY handle

HAZET No.	mm	l mm	EAN-No. 4000896+
-----------	----	------	------------------

- Bumping and Planishing Hammer
- 154 mm
- 2 round faces of different sizes

1935	○ 40 ○ 30	308	008193
------	-----------	-----	--------

- Stretching and Planishing Hammer
- 103 mm
- Round faces, finely chequered, milled

1937 K	□ 24 ○ 32	305	008209
--------	-----------	-----	--------

- Stretching and Planishing Hammer
- 96 mm
- Round faces, finely chequered, milled

1938 K	□ 35 ○ 40	310	008216
--------	-----------	-----	--------



HAZET No.	mm	l mm	EAN-No. 4000896+
-----------	----	------	------------------

- Stretching and Planishing Hammer
- 103 mm
- Round faces, finely chequered, milled

1939 K	□ 40 ○ 46	300	008223
--------	-----------	-----	--------

- Planishing and Embossing Hammer
- 160 mm
- Round face and ball

1940	○ 40 ○ 17	309	008230
------	-----------	-----	--------

- Planishing and Picking Hammer
- 135 mm
- Round face and pointed head

1942	○ 36 •	309	008254
------	--------	-----	--------

Body Hammers



HAZET No.	mm	l mm	EAN-No. 4000896+
-----------	----	------	------------------

- Planishing and Cross-Pein Hammer
- 135 mm
- Round face and curved, sharp pein

1943	○ 40 — 15	309	008261
------	-----------	-----	--------

- Bumping and Picking Hammer
- 165 mm
- Round face and straight pein

1944	○ 41 ○ 10	325	008278
------	-----------	-----	--------

- Planishing and Picking Hammer
- 210 mm
- Round face and curved pein

1945	○ 41 ○ 6	305	008285
------	----------	-----	--------



- Bumping and Rubber Hammer
- Aluminium Hammer

HAZET No.	mm	l mm	EAN-No. 4000896+
-----------	----	------	------------------

- Bumping and Rubber Hammer
- Round face and replaceable plastic cover

1948	○ 53 ○ 34	380	008292
------	-----------	-----	--------

- Bumping and Planishing Hammer
- 160 mm
- Round face and curved pein

1949-1	○ 32 ■ 37x12	320	008315
--------	--------------	-----	--------

- Bumping and Planishing Hammer
- 115 mm
- Round face and wide pein

1949-2	○ 30 — 25	300	008322
--------	-----------	-----	--------

- Aluminium Hammer
- Flat, half-round

1950	○ 30	310	008339
------	------	-----	--------

Plastic Hammers



- Replaceable Desmopan® heads
- Ergonomic ash wood handle
- Zinc-cast center part with protective guide bush for the handle

HAZET No.	d mm	EAN-No. 4000896+
-----------	------	------------------

1952-23	23	008483
---------	----	--------

1952-28	28	008506
---------	----	--------

1952-35	35	008520
---------	----	--------

1952-40	40	008544
---------	----	--------

1952-50	50	008551
---------	----	--------

1952-60	60	008568
---------	----	--------

Spare Tips



- Per pair
- Made of extremely tough Desmopan® material

To remove worn heads turn to left.
Bump on new heads with a hammer
or pressure without turning

HAZET No.	d mm	EAN-No. 4000896+
1952-023	23	008384
1952-028	28	008391
1952-035	35	008414
1952-040	40	008438
1952-050	50	008452
1952-060	60	008476

Plastic Hammers



- **Non-bouncing:** due to steel-ball filling in the hammer head and the special material of impact heads
- Replaceable hammer tips made of special plastic material, splinterproof and non-crumbling
- Gentle and careful working
- Abrasionproof, long service-life
- Steel tube handle
- Plastic handle cover, resistant to oil and gasoline

HAZET No.	d mm	l ₁ mm	EAN-No. 4000896+
1953-30	30	113	008636
1953-35	35	115	008650
1953-40	40	123	008667
1953-50	50	133	008681
1953-60	60	163	008698

Spare Tips



- Per pair
- Special plastic material splinterproof and non-crumbling

Cramp worn heads in a vice and twist to remove.
Use a hammer to bump on new heads.

HAZET No.	d mm	EAN-No. 4000896+
1953-030	30	008575
1953-035	35	008582
1953-040	40	008599
1953-050	50	008612
1953-060	60	008629

Special Bumping Mallet



- With permanent plastic filler for non-damaging bumps

Special Bumping Mallet



HAZET No.	l mm	EAN-No. 4000896+
Rubber body 70 x 70 mm		
1959-2	260	102259
Handle adjustable 90° Rubber body 70 x 140 mm		
1959-3	280	008728

Body Sheet Ripper



- Special steel
- With 1 spare blade

HAZET No.	l mm	EAN-No. 4000896+
1960	275	008735

Car Body Chisel



- For cutting sheet metal, welding spots, welding grooves, etc.
- With hand guard
- Blade size: 7 x 26 mm
- Chrome-Vanadium

HAZET No.	l mm	EAN-No. 4000896+
1960-5	240	008759

Sheet Metal Profile Snips

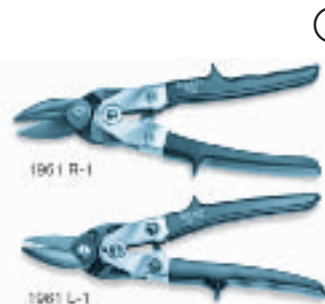

- For figure cutting and straight cuts
- For sheet metal up to 1.8 mm, VA-steel sheets up to 1.2 mm
- With lever transmission system
- Handles with plastic cover
- Special steel
- Shear head drop-forged, hardened and tempered
- Cutting edges induction hardened

HAZET No.	l mm	EAN-No. 4000896+
R = right hand cutting		
1961 R-1	260	008803
L = left hand cutting		
1961 L-1	260	008780

Universal Sheet Metal Snips



- For figure cutting and straight cuts
- With lever transmission system
- Handles with plastic cover
- Special steel
- Shear head drop-forged, hardened and tempered
- Cutting edges induction hardened

HAZET No.	l mm	EAN-No. 4000896+
R = right hand cutting		
1961 R-2	260	008810
L = left hand cutting		
1961 L-2	260	008797

Sheet Metal Snips "Knabber"



- For cutting of sheet metal up to 1.2 mm for plastic pipes up to 2 mm wall thickness as well as for transparent, corrugated plastic material
- Replaceable blade, relief-ground
- Chip breaker made of chrome steel
- Handle with plastic cover

HAZET No.	l mm	EAN-No. 4000896+
1962 N	275	008827
Spare knife for 1962 N		
1962 N-1		008834

Hand Riveting Tool



- For safe and fast rivet joints
- For aluminium **blind rivets** up to 5 mm ϕ , and stainless steel **blind rivets** up to 4 mm ϕ
- Patented intermediate lever reduces expenditure of force and absorbs pull-off strength
- Well-tried for the **industrial application**
- Jaws are manufactured according to a special technique
- Chrome-Vanadium, handles plastic coated

HAZET No.	l mm	EAN-No. 4000896+
1963	260	008889

Sheet Metal Punches



- For sheet metal punching up to 1 mm during spot-welding (MAG-welding)
- Plastic handle covers
- Chrome-Vanadium
- Surface chrome-plated
- DP – German Patent

To be used with HAZET Flange Tool 1932

Sheet Metal Punches

HAZET No.	l mm	Ø mm	EAN-No. 4000896+
1964-50	300	5,0	009039
1964-55	300	5,5	009077
1964-70	300	7,0	009121



Replaceable punching set consisting of: punch, die plate, screw and headless screw for 1964-50

1964-050	008995
ditto for 1964-55	
1964-055	009008
ditto for 1964-70	
1964-070	009015

Wedge Set



- For hot galvanized surfaces
- Beech wood

contents:
1965-1 2 3 4 5

HAZET No.	l x b x h	EAN-No. 4000896+
Set with 5 parts		
1965/5	-	009220
Wedges		
1965-1	180 x 53 x 34	009169
1965-2	158 x 40 x 50	009176
1965-3	130 x 41 x 40	009190
1965-4	92 x 30 x 25	009206
1965-5	92 x 47 x 20	009213

Wedge



- For car body work e.g. for stripping mouldings, covers, graphics, etc. without any damaging
- Plastic

HAZET No.	l x b x h	EAN-No. 4000896+
1965-20	190 x 25 x 25	009183

Combination Lever



- For fast and easy removing of mouldings and door covering
- Application of plugs and plastic clips
- Removing of protective caps and covers
- Avoids damage of lacquered surfaces, plastic and metal parts
- 270 x 22 mm

Combination Lever

HAZET No.	EAN-No. 4000896+
1965-21	087839

Impact Extractors

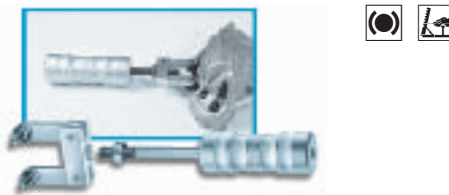

- For **disk brake linings** e.g. on OPEL, BMW, MERCEDES-BENZ, VW-AUDI, FORD, FIAT, VOLVO, SAAB, etc.
- Replaceable heads
- Special steel
- Surface chrome-plated

HAZET No.	l mm	EAN-No. 4000896+
Tool body with claw, Claw prongs-Ø 5.9 mm		
1966-1	245	009275
Tool body with claw, Claw prongs-Ø 4 mm		
1966-2	245	009282

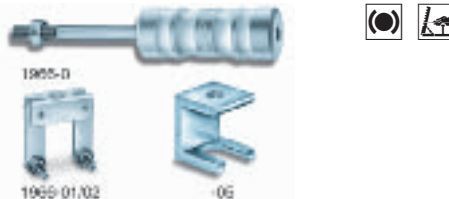

HAZET No.	l mm	EAN-No. 4000896+
Tool body without claws		
1966-0	210	009237
Claw for disk brake linings, 5.9 mm prongs Ø		
1966-01	50	009244
Claw for disk brake linings, 4 mm prongs Ø		
1966-02	50	009251
Claw for windscreen wiper arms		
1966-05	38	009268

Welding Spot Cutter



- For exact welding spot reaming in car body construction and sheet metal fabrication
- No warped or torn materials
- 7 mm hexagon shank prevents slippage in drill chuck
- Fits power drills of all type
- Replaceable cutting crown made of high-speed steel (oiled)
- Cutting crown for use at both ends
- With screw for gauge depth adjustment (*)

HAZET No.	l mm	Ø mm	EAN-No. 4000896+
1967	70	11	009312



Cutter crowns, set of 10 parts for 1967		
1967-01	009329	
Center for 1967		
1967-02	009336	

Welding Spot Drills



- For clean and burr-free holes in welding spots
- Self-cutting center drill point – resharpenable –
- High-strength steel (HSS), blued

1967-90 esp. for FORD-Mondeo axles

HAZET No.	Ø mm	l mm	EAN-No. 4000896+
1967-70	7	74	009343
1967-80	8	79	009350
1967-90	9	79	009367

Impact Drive Shaft Puller



- For pulling-off rear axles / full floating axles as well as wheel hubs e.g. for OPEL, FORD and NISSAN
- Bolt Ø 4-14 mm circle Ø 100-150 mm
- Special steel
- Surface galvanized

HAZET No.	l mm	EAN-No. 4000896+
1969-14	470	009558

Impact Puller



- For removing door hinge bushes
- Special steel
- Surface galvanized

without extraction pin, for extraction pins see HAZET 1970-1 up to 4

HAZET No.	l mm	EAN-No. 4000896+
1970	310 x 220	009565

Extraction Pins



- For Impact Puller HAZET 1970
- Special steel for excessive use
- Surface burnished

HAZET No.	Ø mm	l mm	EAN-No. 4000896+
1970-1	3,85	110	009572
1970-2	5,00	110	009589
1970-3	5,00	125	009596
1970-4	5,50	110	009602

Impact Puller



- For extraction of **solid** dowel pins on door hinges, on FORD
- With 2 replaceable sockets for pins of 8 and 10 mm ϕ
- With plastic handle
- Special steel

contents:
1971 1971-1 2

HAZET No.	l mm	EAN-No. 4000896+
1971/3	297	009640
Impact Puller (without sockets)		
1971	297	009619
Socket for 8 mm pin ϕ FORD-Fiesta, Escort since 1986		
1971-1	40	009626
Socket for 10 mm pin ϕ FORD-Fiesta since 1989		
1971-2	40	009633

Aligning Tool for Doors



- For easy and clean re-alignment of doors on passenger cars and commercial cars (height adjustment) as well as tailgates on hatchback vehicles (adjustment of door gap-width)
- Flat steel Chrome-Vanadium aligning rod made of special steel
- Surface chrome-plated

HAZET No.	l mm	EAN-No. 4000896+
Set, 4 parts: Aligning rod with 3 pins, stored in the rod's handle		
contents: 1973-1 2 3 4		
1973/4	660	009718
Aligning Rod		
1973-1	660	009664
Pin 19 mm ϕ		
1973-2	-	009688
Pin 12 mm ϕ		
1973-3	-	009695
Pin 9.3 mm ϕ		
1973-4	-	009701

Pick-Up Tool with Claws



- For **picking up small items which are not magnetic** in areas with restricted access
- Flexible
- Surface chrome-plated

HAZET No.	l mm	EAN-No. 4000896+
1975	540	009725

Magnetic Pick-Up Tools



- With permanent magnet
 - Flexible shank
 - Ergonomic plastic handle
- lifting capacity
- | | |
|--------|--------|
| 1976 | 4500 g |
| 1976-1 | 7500 g |
| 1976-2 | 1100 g |

HAZET No.	l mm	EAN-No. 4000896+
1976	530	009732
1976-1	530	009749
1976-2	465	009763

Inspection Mirror



- Illuminates restricted inspection areas
- **With light**
- Thumb wheel on handle for mirror adjustment by 90°
- Flexible shaft allows further angular adjustment
- On/off switch at the handle, with 2 batteries (Mignon 1.5 V) in the handle
- Mirror dimensions: 30 x 55 mm
- Plastic

HAZET No.	l mm	EAN-No. 4000896+
1977-1	620	009800



Mirror and 2 light bulbs for 1977-1		
1977-01/3	-	009794
Spare light bulb		
1977-02	-	070442

Flexible Inspection Light



- For the illumination of areas with restricted access e.g. at the dashboard
- High intensity light with flexible shaft
- Plastic

Flexible Inspection Light

HAZET No.	EAN-No. 4000896+
1978-1	076147
Spare light	
1978-01	076154

Rechargeable Utility Light



- Optimal illumination of the work area
- 7 ultra bright, white LED 530 LUX (at a distance of 34 cm)
- High luminous efficiency – comparable with a 60 watt bulb
- Cold light – no risk of burning
- Environmentally friendly NiMH-battery
- Metal swivel hook
- Stability due to big base (ϕ 70 mm)
- Serviceable life of the LED up to 20000 hours
- Contactless charging by induction
- 5 operating hours in fully charged state
- 3 hours charging time
- Insensitive to shocks

HAZET No.	EAN-No. 4000896+
1979-1	106196

Hack Saw



- With blade tensioning end screw
- Plastic handle and front bow
- With 1 saw blade
- For 300 mm saw blades
- Special steel

HAZET No.	l mm	EAN-No. 4000896+
1980 N	390	009824

Saw Blade		
• 24 teeth p. inch		
• 300 mm		
• One-sided		
• High-strength steel (HSS) fully hardened and elastic		
• DIN 6494, form A		
1980 B-2	300 x 12,5 x 0,63	009817

Small Hack Saw



- For saw blades 150 mm
- With 1 saw blade
- Handle made of glass fiber reinforced plastic
- Special steel St 2 K 40

Small Hack Saw

HAZET No.	l mm	EAN-No. 4000896+
1981	252	009831
Saw Blade made of chrome-alloyed tool steel		
1981-01	150	009848

Tool Holder



Universal Clamping Rails

- Handy storage for any kind of tools
- Rail with 2 long holes, allows variable fixation even on perforated sheet metal displays
- Two flexible clamps embrace each tool without damaging it
- Flexible clamps made of oil resisting and antifreezing plastic, **flexible, long-lived**
- Rail made of anodized light metal

HAZET No.	l mm	EAN-No. 4000896+
2025 X	440	010301
2025 X-1	150	010424

Tool Hangers and Guide Rails

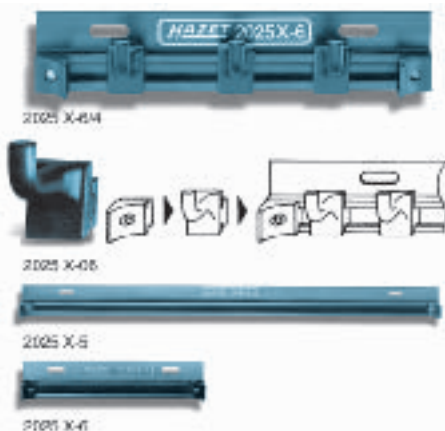

HAZET No.	l mm	EAN-No. 4000896+
Guide Rail, complete, with 3 tool hangers 150 mm for fixing on walls		
2025 X-6/4	150	058259
Tool Hanger self locking, to be inserted into guide rails 2025 X-5 and -6		
2025 X-06	25	010394
Guide Rail for a.m. tool hangers		
2025 X-5	440	010479
2025 X-6	150	010486

Sales Display Chest



290 x 305 x 180

For small parts,
24 drawers, empty,
plastic, colour RAL 5013
290 x 305 x 180 mm

HAZET No.	EAN-No. 4000896+
2026-5 VS L	100927
10 sheets for transverse drawer partition	
2026-01/10 VS L	100934

Hex Head Wrenches

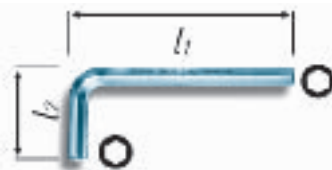

- For inside hexagon screws
- Chrome-Vanadium
- Surface nickel-plated
- DIN ISO 2936

* = not according to DIN

HAZET No.	S mm	l ₁ mm	l ₂ mm	EAN-No. 4000896+
2100-015	1,5	46,5	15,5	011261
2100-02	2,0	52,0	18,0	011278
2100-025	2,5	58,5	20,5	011285
2100-03	3,0	66,0	23,0	011308
2100-035 *	3,5	68,5	25,5	011315
2100-04	4,0	74,0	29,0	011322
2100-045 *	4,5	77,5	30,5	011339
2100-05	5,0	85,0	33,0	011346
2100-06	6,0	96,0	38,0	011353
2100-07	7,0	102,0	41,0	011360
2100-08	8,0	108,0	44,0	011377
2100-09 *	9,0	119,0	47,0	011391
2100-10	10,0	122,0	50,0	011407
2100-11 *	11,0	130,0	53,0	011414
2100-12	12,0	137,0	57,0	011421
2100-13 *	13,0	146,0	63,0	011438
2100-14	14,0	154,0	70,0	011445
2100-17	17,0	177,0	80,0	011452
2100-19	19,0	199,0	89,0	011469
2100-22	22,0	222,0	102,0	011476
2100-24	24,0	248,0	114,0	011483
2100-27	27,0	277,0	127,0	011490

- **American sizes**
- For inside hexagon screws
- Chrome-Vanadium
- Surface nickel-plated

HAZET No.	S mm	l ₁ mm	l ₂ mm	EAN-No. 4000896+
2100 A-5/64	5/64	52,0	18,0	011698
2100 A-3/32	3/32	58,5	20,5	011643
2100 A-1/8	1/8	66,0	23,0	011629
2100 A-9/32	9/32	74,0	29,0	011681
2100 A-3/16	3/16	84,5	32,5	011636
2100 A-7/32	7/32	90,5	35,5	011728
2100 A-1/4	1/4	96,5	38,5	011612
2100 A-9/32	9/32	102,0	42,0	011742
2100 A-5/16	5/16	108,0	44,0	011674
2100 A-3/8	3/8	121,5	49,5	011667
2100 A-7/16	7/16	130,0	53,0	011711
2100 A-1/2	1/2	144,5	62,5	011605
2100 A-9/16	9/16	154,5	69,5	011735
2100 A-5/8	5/8	176,0	76,0	011704
2100 A-3/4	3/4	199,0	89,0	011650

Hex Head Wrenches Sets



- In plastic clip
- 6 parts, metric sizes

contents:
2100-03 04 05 06 08 10

HAZET No.	EAN-No. 4000896+
2100/6 H	011551



Plastic clip, empty, for 2100/6 H

2100/6 HL	011568
-----------	--------



in plastic rolls

HAZET No.	EAN-No. 4000896+
-----------	------------------

7 parts, metric sizes

contents:
2100-02 03 04 05 06 07 08

2100/7 P	011575
----------	--------

10 parts, metric sizes

contents:
2100-02 03 04 05 06 07 08 09 10 12

2100/10 P	011506
-----------	--------

14 parts, metric sizes

contents:
2100-02 03 04 05 06 07 08
09 10 12 14 17 19 22

2100/14 P	011537
-----------	--------

9 parts, American sizes

contents:
2100 A-5/64 3/32 1/8 5/32 3/16 7/32 1/4 5/16 3/8

2100 A/9 P	011780
------------	--------

11 parts, American sizes

contents:
2100 A-5/64 3/32 1/8 5/32 3/16 7/32
1/4 5/16 3/8 1/2 9/16

2100 A/11 P	011759
-------------	--------

13 parts, American sizes

contents:
2100 A-5/64 3/32 1/8 5/32 3/16 7/32
1/4 5/16 3/8 1/2 9/16 5/8 3/4

2100 A/13 P	011766
-------------	--------



Hex Head Wrenches Sets



with ring

HAZET
No. EAN-No.
4000896+

7 parts, metric sizes

contents:
2100-02 025 03 04 05 06 08

2100/7 R 011599

7 parts, American sizes

contents:
2100 A- $\frac{3}{32}$ $\frac{1}{8}$ $\frac{5}{32}$ $\frac{3}{16}$ $\frac{7}{32}$ $\frac{1}{4}$ $\frac{5}{16}$

2100 A/7 R 011773

Offset Screwdriver Set



- For inside hexagon screws
- With handy hinged tool holder
- Metric sizes
- 6 parts:
s 2 5 3 4 5 6 8

HAZET
No. EAN-No.
4000896+

2100/6 KH 072590

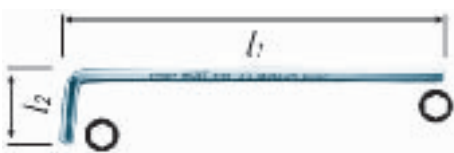

- Long style
- For inside hexagon screws
- Metric sizes
- Chrome-Vanadium
- Surface nickel-plated
- DIN ISO 2936 L

HAZET
No. S mm l1 mm l2 mm EAN-No.
4000896+

2100 Lg-02	2,0	102,0	18,0	011797
2100 Lg-025	2,5	114,5	20,5	011803
2100 Lg-03	3,0	129,0	23,0	011810
2100 Lg-04	4,0	144,0	29,0	011827
2100 Lg-05	5,0	165,0	33,0	011834
2100 Lg-06	6,0	186,0	38,0	011841
2100 Lg-08	8,0	208,0	44,0	011858
2100 Lg-10	10,0	234,0	50,0	011865
2100 Lg-12	12,0	262,0	57,0	011872
2100 Lg-14	14,0	294,0	70,0	011889

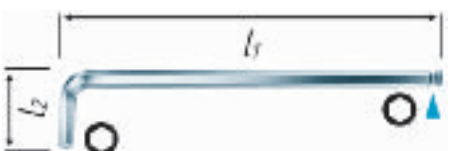

- **With ball hex**,
ball hex = angular movement 20°
- Long style
- For inside hexagon screws
- Metric sizes
- Chrome-Vanadium
- Surface nickel-plated

Hex Head Wrenches

HAZET
No. S mm l1 mm l2 mm EAN-No.
4000896+

2105 Lg-015	1,5	91,5	15,5	011896
2105 Lg-02	2,0	102,0	18,0	011902
2105 Lg-025	2,5	114,5	20,5	011919
2105 Lg-03	3,0	129,0	23,0	011926
2105 Lg-04	4,0	144,0	29,0	011933
2105 Lg-05	5,0	165,0	33,0	011940
2105 Lg-06	6,0	186,0	38,0	011957
2105 Lg-07	7,0	207,0	43,0	011964
2105 Lg-08	8,0	208,0	48,0	011971
2105 Lg-10	10,0	234,0	55,0	011988
2105 Lg-12	12,0	262,0	68,0	011995

- **With ball hex**,
ball hex = angular movement 20°
- Long style
- For inside hexagon screws
- American sizes
- Chrome-Vanadium
- Surface nickel-plated

HAZET
No. S mm l1 mm l2 mm EAN-No.
4000896+

2105 A Lg-0.05	0,05	81	13	085934
2105 A Lg-$\frac{1}{16}$	$\frac{1}{16}$	92	16	085941
2105 A Lg-$\frac{5}{64}$	$\frac{5}{64}$	102	18	085958
2105 A Lg-$\frac{3}{32}$	$\frac{3}{32}$	114	20	085965
2105 A Lg-$\frac{1}{8}$	$\frac{1}{8}$	129	23	085972
2105 A Lg-$\frac{5}{32}$	$\frac{5}{32}$	144	29	085989
2105 A Lg-$\frac{3}{16}$	$\frac{3}{16}$	165	33	085996
2105 A Lg-$\frac{7}{32}$	$\frac{7}{32}$	176	36	086009
2105 A Lg-$\frac{1}{4}$	$\frac{1}{4}$	186	38	086016
2105 A Lg-$\frac{5}{16}$	$\frac{5}{16}$	208	44	086023

Hex Head Wrenches Sets



- With ring
- **With ball hex**
- 7 parts, metric sizes

contents:
2105 Lg-02 03 04 05 06 07 08

HAZET
No. EAN-No.
4000896+

2105 Lg/7 R 012008



- In plastic clip
- **With ball hex**

HAZET
No. EAN-No.
4000896+

9 parts, metric sizes

contents:
2105 Lg-015 02 025 03 04 05 06 08 10

2105 Lg/9 H 012015

Plastic clip, empty, for 2105 Lg/9 H

2105 Lg/9 HL 012022

10 parts, American sizes

contents:
2105 A Lg-0.05 $\frac{1}{16}$ $\frac{5}{64}$ $\frac{3}{32}$ $\frac{1}{8}$
 $\frac{5}{32}$ $\frac{3}{16}$ $\frac{7}{32}$ $\frac{1}{4}$ $\frac{5}{16}$

2105 A Lg/10 H 083749

Plastic clip, empty, for 2105 Lg/10 H

2105 A Lg/10 HL 086030

Offset Screwdrivers

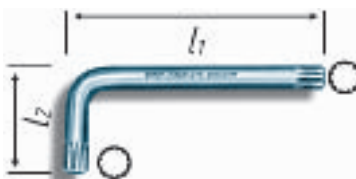

- For screws with internal serration (XZN)
- Chrome-Vanadium
- Surface burnished

HAZET
No. M l1 mm l2 mm EAN-No.
4000896+

2111-05	5	77	30	012039
2111-06	6	86	34	012046
2111-08	8	98	40	012053
2111-10	10	110	46	012060
2111-12	12	124	52	012077
2111-14	14	139	59	012084
2111-16	16	156	71	012091

TORX® Offset Screwdrivers

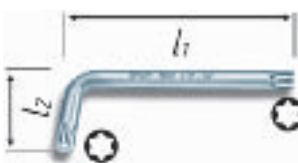

- For inside TORX® screws
- Chrome-Vanadium

HAZET
No. S mm l1 mm l2 mm EAN-No.
4000896+

2115-T 6	1,70	44,5	18,5	012220
2115-T 7	1,99	50,5	18,5	012244
2115-T 8	2,31	51,0	19,0	012251
2115-T 9	2,50	51,0	19,0	012268
2115-T 10	2,74	54,0	20,0	012121
2115-T 15	3,27	57,5	21,5	012138
2115-T 20	3,86	61,0	23,0	012145
2115-T 25	4,43	64,5	24,5	012152
2115-T 27	4,99	69,5	26,5	012169
2115-T 30	5,52	76,0	30,0	012176
2115-T 40	6,65	83,0	33,0	012183
2115-T 45	7,82	91,0	37,0	012190
2115-T 50	8,83	104,0	41,0	012206
2115-T 55	11,22	120,0	47,0	012213
2115-T 60	13,25	134,0	52,0	012237

TORX® Offset Screwdriver Sets



- For inside TORX® screws
- With ring
- 7 parts

contents:
2115-T8 T10 T15 T20 T25 T30 T40

HAZET
No. EAN-No.
4000896+

2115-T/7 R 012114



- For inside TORX® screws
- In plastic roll
- 13 parts

TORX® Offset Screwdriver Sets

contents:

2115-T 7 T 8 T 9 T10 T15 T25
T27 T30 T40 T45 T50 T55 T60

HAZET No.	EAN-No. 4000896+
2115-T/13 P	012107

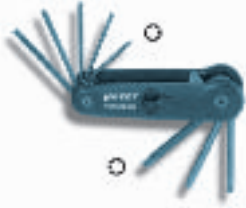

- For inside TORX® screws
- With handy hinged tool holder

8 parts:

2115-T 9 T10 T15 T20
T25 T27 T30 T40

HAZET No.	EAN-No. 4000896+
2115/8 KH	072583

TORX® Offset Screwdrivers



- For inside TORX® screws with pin
- With bore hole on both sides
- Chrome-Vanadium

HAZET No.	mm	l ₁ mm	l ₂ mm	EAN-No. 4000896+
2115-T 7 H	1,99	50,5	18,5	059300
2115-T 8 H	2,31	51,0	19,0	059317
2115-T 9 H	2,50	51,0	19,0	059324
2115-T 10 H	2,74	54,0	20,0	059331
2115-T 15 H	3,27	57,5	21,5	059348
2115-T 20 H	3,86	61,0	23,0	059355
2115-T 25 H	4,43	64,5	24,5	059362
2115-T 27 H	4,99	69,5	26,5	059379
2115-T 30 H	5,52	76,0	30,0	059386
2115-T 40 H	6,65	83,0	33,0	059393
2115-T 45 H	7,82	91,0	37,0	059409
2115-T 50 H	8,83	104,0	41,0	059416
2115-T 55 H	11,22	120,0	47,0	059423
2115-T 60 H	13,25	134,0	52,0	059430

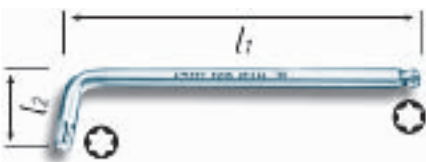

- For inside TORX® screws
- Long style
- Long end with ball hex angular movement 20°
- Chrome-Vanadium

HAZET No.	mm	l ₁ mm	l ₂ mm	EAN-No. 4000896+
2116 Lg-T 9	2,50	67,0	19,0	012374
2116 Lg-T 10	2,74	76,0	20,0	012275
2116 Lg-T 15	3,27	86,5	20,5	012282
2116 Lg-T 20	3,86	98,0	22,0	012299
2116 Lg-T 25	4,43	100,5	22,5	012305
2116 Lg-T 27	4,99	111,5	25,5	012312
2116 Lg-T 30	5,52	125,0	30,0	012329
2116 Lg-T 40	6,65	139,0	33,0	012336
2116 Lg-T 45	7,82	145,0	37,0	012343
2116 Lg-T 50	8,83	149,0	41,0	012350
2116 Lg-T 55	11,22	157,0	47,0	012367
2116 Lg-T 60	13,25	167,0	52,0	051878

TORX® Offset Screwdriver Set



- For inside TORX® screws
- With ball hex
- In plastic clip
- 8 parts

contents:

2116 Lg-T9 T10 T15 T20 T25 T27 T30 T40

HAZET No.	EAN-No. 4000896+
2116 Lg/8 H	051519



Plastic clip, empty, for 2116 Lg/8 H

2116 Lg/8 HL	051502
--------------	--------

TORX® Offset Screwdriver



- For the screws at the **door fixing and locking devices**, for aligning doors, e.g. for VW-Golf III, Polo, Vento, AUDI 100, OPEL Astra F, BMW E 34
- With trinamic® handle

HAZET No.	mm	EAN-No. 4000896+
2117-T 40	6,65	051908

General Workshop Equipment

Half Round Files



- Half round
- Teeth (cut): 2 = medium
- Plastic handle
- Special steel
- DIN 7261, form E

HAZET No.	l ₁ mm	EAN-No. 4000896+
2119- 8	200	012398
2119-10	250	012381

Round Files

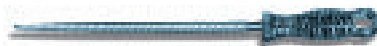

- Round
- Teeth (cut): 2 = medium
- DIN 7261, form F

HAZET No.	l ₁ mm	EAN-No. 4000896+
2120- 8	200	012411
2120-10	250	012404

Flat Hand Files



- Flat
- Teeth (cut): 2 = medium
- DIN 7261, form A

HAZET No.	l ₁ mm	EAN-No. 4000896+
2122- 8	200	012435
2122-10	250	012428

Three Square Files



- Three square
- Teeth (cut): 2 = medium
- DIN 7261, form C

HAZET No.	l ₁ mm	EAN-No. 4000896+
2123- 8	200	012473
2123-10	250	012466

Magneto Files



- Special steel
- Set in plastic roll
- 6 parts

HAZET No.	EAN-No. 4000896+
2125/6 P	012480

Thread Restorers



- For restoring damaged or worn-out inside or outside threads
- Special steel
- Galvanized, yellow chromized

HAZET No.	l mm	EAN-No. 4000896+
for threads M 5 to M 27		
2126	230	012497
for threads 5/16 to 1.1/2		
2126 A	230	012503

Twist Drill Bits in Case



- HSS-G
- ϕ 1 – 13 mm, increasing by 0.5 mm
- DIN 338
- 118° standard point

HAZET No.	EAN-No. 4000896+
2128-1	103775

Wire Brushes



- For e.g. steel working
- 4 rows
- Trim size 25 mm
- Solid wire bristles
- Wooden body
- With handle hole

HAZET No.	l mm	EAN-No. 4000896+
2130	290	012510

Wire Brushes



- For e.g. sheet steel made of V2A and aluminium
- 4 rows
- V2A bristles
- Wooden body
- With handle hole

HAZET No.	l mm	EAN-No. 4000896+
2130-1	280	012527

Spark Plug Brush



- For cleaning of electrodes and contacts on spark plugs
- Special corrugated brass wire bristles
- 3 rows
- Trim size 15 mm
- Wooden body

HAZET No.	l mm	EAN-No. 4000896+
2131	150	012541

Machinist's Hammers



- Quality grade A
- Hickory handle
- DIN 1041

HAZET No.		EAN-No. 4000896+
2140- 2	200 g	012640
2140- 3	300 g	012657
2140- 4	400 g	012688
2140- 5	500 g	012695
2140- 8	800 g	012725
2140-10	1000 g	012633

Ball Peen Hammers



- Hickory handle

HAZET No.		EAN-No. 4000896+
2141-0	½ lbs	012732
2141-1	¾ lbs	012756
2141-2	1 lbs	012763
2141-3	1½ lbs	012770
2141-4	2 lbs	012787

Rubber Hammer



- 54 mm ø x 90 mm
- DIN 5128

HAZET No.		EAN-No. 4000896+
2143	225 g	012794

Precision Knife-Edge Straightedge



- For inspecting the surface evenness (flatness) of e.g. cylinder heads
- Measuring edge hardened
- Ground and lapped
- With insulating handle
- In artificial leather case
- DIN 874/0

HAZET No.	l mm	EAN-No. 4000896+
2145-500	500	073146

Feeler Gauges



e.g. for checking of the spark plug air gap

HAZET No.		EAN-No. 4000896+
-----------	--	------------------

mm sizes = Feeler Gauge Set D, 20 blades, 0.05–1.0 mm

2147	0,05-1,0	012824
------	----------	--------

2147 MS: made of brass – **non-magnetic** – e.g. for adjusting the sensors on anti locking systems resp. checking the spark plug air gap on spark plugs made of platinum

20 blades, increasing by 0.05-1.0 mm

2147 MS	0,05-1,0	057603
---------	----------	--------

20 blades, 0.002–0.40" SAE

2147 A	0,002-0,040" SAE	012831
--------	------------------	--------

Marking Tools



- For marking metal and other materials with smooth surfaces
- Special steel
- Surface burnished

HAZET No.	l mm	EAN-No. 4000896+
2150	240	013012



- For marking metal and other materials with smooth surfaces up to a hardness of HRC60
- Needle made of hard metal
- With clip
- All-metal execution

HAZET No.	l mm	EAN-No. 4000896+
2150-2	150	013036



Scriber tip, 2 mm ø, for 2150-2

2150-02	013029
---------	--------

Stethoscope



- For the localization of damaged parts e.g. axles, bearing and gearbox
- Steel tip 180 mm
- Membrane with efficient transmission rate

Stethoscope



HAZET No.	l mm	EAN-No. 4000896+
2151	1080	013043
Ear tips for 2151, per pair		
2151-02/2		062287

Testing Set



- Test appliance for car electricity and electronic
- For trouble shooting on electronic components
- 3-48 V
- Charge indication 2 LED (= charge and positive or negative pole)
- Probe tip, needle with sliding mechanism, additional set of crocodile clip and probe tip
- Cable length 130 cm
- Set with 3 parts

HAZET No.	l mm	EAN-No. 4000896+
-----------	------	------------------

Test appliance for car electricity and electronic

2152/3	156	013098
--------	-----	--------

Basic appliance

2152	156	013067
------	-----	--------

Crocodile clip only

2152-01	62	013074
---------	----	--------

Probe tip only

2152-02	98	013081
---------	----	--------

Test Cable "Power Probe"



- For testing electrical components e.g. relays and **installed** petrol pumps
- Application range: 6–24 V (motorcycles, passenger cars, commercial vehicles, boats)
- Cable length of 6 m allows testing e.g. the trailer light and the connector socket for the trailer jumper cable
- Short circuit proof, 7.5 A fuse protection with manual reset

HAZET No.	l mm	EAN-No. 4000896+
-----------	------	------------------

2152-6	6000	082643
--------	------	--------

Car Light Tester



- With probe tip (10 mm long) and protective cap
- Cable with crocodile clip
- 6-24 V

HAZET No.	l mm	EAN-No. 4000896+
-----------	------	------------------

2153	120	013111
------	-----	--------

Spring-Return Rules



- Euro-Standard II
- 2 m
- Solid ABS-plastic housing ϕ 54 mm

HAZET No.	l mm	EAN-No. 4000896+
2154		013135



- **For inside and outside measurements**
- Euro-Standard II
- 2 m
- Solid ABS-plastic housing, 76 x 56 mm

HAZET No.	l mm	EAN-No. 4000896+
2154-2	76 x 56	013159



- For e.g. measuring the car body during body alignment work
- Euro Standard II
- **5 m**
- Solid ABS-plastic housing, 88 x 64 mm

HAZET No.	l mm	EAN-No. 4000896+
2154-5		013173

Vernier Caliper



- Measuring range up to 150 mm
- With depth gauge
- mm and inch increments
- Nonius 0.05 mm and 1/128
- With locking screw
- In pocket
- Made of stainless steel
- DIN 862

HAZET No.	l mm	EAN-No. 4000896+
2154-10	234	013142

Digital Caliper



- Measuring range up to 150 mm
- With depth gauge
- Reversible from mm to inch
- With interface RS 232 C for data processing
- Switch button
- With battery
- In wooden box
- Made of stainless steel
- DIN 862

Digital Caliper

HAZET No.	l mm	EAN-No. 4000896+
2154-20	234	013166

Precision Micrometers



- With clamping ring and ratchet stop
- Spindle hidden inside, ground and hardened, adjustable
- With insulating plates
- Carbide tipped measuring surface
- Increments 0.5 mm reading 0.01 mm
- In wooden box
- DIN 863/III

HAZET No.	EAN-No. 4000896+
2155-25	073269

measuring range 0 – 25 mm

additionally with setting gauge measuring range 25 – 50 mm

HAZET No.	EAN-No. 4000896+
2155-50	073276

Cable Stripping Knives

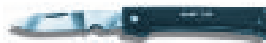

- Blade made of stainless steel
- Plastic handle

HAZET No.	l mm	EAN-No. 4000896+
2156	110	013180



- For quick and precise **dismantling of all round cables** mostly required, 8-28 mm ϕ
- Depth of cut adjustable by locking screw at the end of handle, therefore no damaging of internal conductor
- Turnable inside blade changes automatically after round cut to axial cut
- Additional hook blade for dismantling segment and flat cables
- With guard cap

HAZET No.	l mm	EAN-No. 4000896+
2156-1	168	013197

Trimming Knife



- Multipurpose Knife
- With spare blades deposit
- One snap-off, straight and hook blade each included
- Housing made of glass fiber reinforced plastic

HAZET No.	l mm	EAN-No. 4000896+
2157	167	013203

Snap-off Blades (7 break-away parts) set with 10 parts each

HAZET No.	EAN-No. 4000896+
2157-04	013210

Straight Blades, set with 10 parts each

HAZET No.	EAN-No. 4000896+
2157-05	013227

Hook Blades, set with 10 parts each

HAZET No.	EAN-No. 4000896+
2157-06	013234

Universal Shears



- **For cutting thin sheet metal, wires, plastics, carpets, etc.**
- One hand operation of the locking device due to ergonomic design
- With locking device
- With round cutter to remove the insulation from wires (1 resp. 1.5 mm²)
- Plastic handle, with bi-material element for optimal application

HAZET No.	l mm	EAN-No. 4000896+
2158	194	057856

Oilers



200 ml, empty

HAZET No.	l mm	EAN-No. 4000896+
2160	245	013289



150 ml, empty

HAZET No.	l mm	EAN-No. 4000896+
2161	170	013296

Grease Guns



- Capacity 500 cm³
- With reinforced hose, nozzle tube and 2 nozzles M 10 x 1

HAZET No.	EAN-No. 4000896+
2162-1	075027

lightweight design, wall thickness 1.0 mm

2162-1	075027
--------	--------

reinforced design, wall thickness 1.5 mm

2162-2	075034
--------	--------

Pry Bars

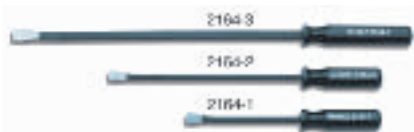

- Flat and bevelled tips allow application in areas with restricted access
- With screwdriver handles
- Solid square blades guarantee high power transmission

HAZET No.	l ₁ mm	l ₂ mm	EAN-No. 4000896+
2164-1	190	300	080274
2164-2	320	460	080267
2164-3	450	600	080250
Set with 3 parts			
2164/3			080281

Pry Bars

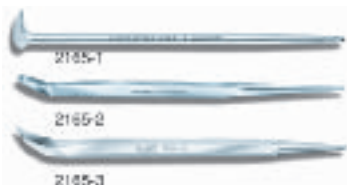

- For knocking bearings and bearing shells in and out, installing and removing of springs, bolts, toothed gears, etc.
- Special steel
- Surface bright nickel-plated

HAZET No.	l mm	EAN-No. 4000896+
2165-1	400	013302
2165-2	400	013319
2165-3	400	013326



- For excessive and heavy use during repair work on commercial vehicles, agricultural and building machinery
- For levering out rotary shaft seal units
- For checking:
 - cab bearings
 - cardan shaft slackness
 - bearing bushings
 - ball-and-socket joints of the steering tie rod and steering rod
- Square blade made of special steel for heavy use passing through the handle
- Big, shock-resistant and ergonomic handles offer comfortable grip and allow two-hand operation

HAZET No.	EAN-No. 4000896+
2166-1	610 mm x 90° 089055
2166-2	910 mm x 45° 089062
2166-3	610 mm x 60° 089079
Set with 3 parts:	
2166-1 2 3	
2166/3	089185

Oil Service

Oil Filter Wrenches



12.5 1/2

- For the operation of oil and fuel filters
- For MANN-oil resp. fuel filter: W 920, W 920/7, W 930, W 930/9, W 940, W 940/15, W 940/20, W 940/25, W 950, W 950/1, W 950/5, W 962/2, W 962/7, W 962/14, W 1130/1, WK 940/4, WK 950/4, WK 962/5, WP 931 and WP 962/3, as well as the KNECHT- and MAHLE-Oil filters: OC 51, OC 83 and OC 214
- □ drive 12.5 = 1/2"
- or outside hexagon 22 mm
- Chrome-Vanadium
- Surface chrome-plated

HAZET No.	mm	mm	EAN-No. 4000896+
2168	22	59	013333



10 3/8

- For operation of oil filters **14-point** ≤ 74.4 mm
- □ drive 10 = 3/8", resp. outside hexagon 27 mm

HAZET No.	mm	mm	EAN-No. 4000896+
2169	27	82	013340

- For the operation of the oil filter cap when changing the oil filter element on MAZDA 3 with 2.0l engine and 6 with 1.8-2.0-2.3l engines
- Flat style: continuous 14-point profile up to the edge

2169-10	27	82	108831
---------	----	----	--------



12.5 1/2

- For the operation of oil filters **15-point** ≤ 92 mm
- □ drive 12.5 = 1/2", resp. outside hexagon 27 mm

HAZET No.	mm	mm	EAN-No. 4000896+
2169-1	27	102	013357



12.5 1/2

- For oil filters that are fitted at an angle ≤ 74 mm (**14-Point**) e.g. on VW-Passat since 1997, AUDI A4 since 1995 as well as comparable vehicle models of SEAT and SKODA

Oil Filter Wrenches

12.5 1/2

- Loosening the oil filter and **collecting the waste oil at the same time**
- Long style
- ● drive 32 mm or □ drive 12.5 = 1/2"

HAZET No.	mm	mm	EAN-No. 4000896+
2169-3	32	96,3	079537

Oil Filter Wrenches Set

12.5 1/2



- For oil filters that are fitted at an angle ≤ 18 -point (MHO Germany filters) ≤ 45 -point (Purflux France filters) same VAG-no. for both filters 028 115 561 E,
- To be used on VW Passat Diesel since 1997, Passat Syncro since 1998, AUDI A4 Quattro since 1995, A6 since 1997, A4 Diesel since 1995, as well as comparable vehicle models of SEAT or SKODA with VAG 4-cyl.-engines **and oil filters fitted at an angle**
- Loosening the oil filter and **collecting the waste oil at the same time**
- Long style
- ● drive 32 mm or □ drive 12.5 = 1/2"

HAZET No.	EAN-No. 4000896+
2169-4/2	082087

Oil Filter Wrench, ≤ 18 -point (MHO Germany filter)

2169-41	082094
---------	--------

Oil Filter Wrench, ≤ 45 -point (Purflux France filter)

2169-42	082100
---------	--------

Oil Filter Wrenches



12.5 1/2

For the operation of oil filters

HAZET No.	mm	mm	EAN-No. 4000896+
-----------	----	----	------------------

- For the operation of plastic oil filter housings **18-point** ≤ 135 mm on MAN commercial vehicles of the series F 2000 and TGA
- □ drive 12.5 = 1/2", resp. outside hexagon 24 mm

2169-5	24	148	100330
--------	----	-----	--------

Oil Filter Wrenches

For the operation of oil filters



HAZET No.	mm	mm	EAN-No. 4000896+
-----------	----	----	------------------

- For the operation of plastic oil filter housings
16-point s 86 mm
e.g. on BMW 316i Limousine Touring, 316ti Compact, 318Ci Cabrio, Coupé, 318i Limousine Touring, Compact, VOLVO V40, S40, S70
- drive 12.5 = 1/2", resp. outside hexagon 24 mm

2169-6	24	96	100293
---------------	----	----	--------

- For the operation of oil filters
14-point s 64 mm
on TOYOTA Yaris, Corolla, MR2 until 99, Starlet, Celica, Avensis, NISSAN Micra, Almera, MAZDA 323, 626, MX-5, Xedos
- drive 12.5 = 1/2", resp. outside hexagon 24 mm

2169-7	24	77	100224
---------------	----	----	--------

- For the operation of MANN oil filters
15-point s 74 mm
on OPEL (oil filters with T-No. 650 401), Kadett E, Corsa A, B, C, Omega A, B, Astra F, G, Vectra A, B, Calibra, Frontera, SAAB 900 2.5 I, 9000 3.0 I, LADA Shiguli 2110 2.0 I
- drive 12.5 = 1/2", resp. outside hexagon 24 mm

2169-8	24	84	100316
---------------	----	----	--------



10	3/8"	
-----------	------	--

- For installing and removing the oil filter cap when changing the oil filter element
- drive 10 = 3/8"
- Chrome-Vanadium
- Surface chrome-plated

HAZET No.	mm	EAN-No. 4000896+
-----------	----	------------------

- **6-point s 27 mm**
MERCEDES-BENZ, type 168 (A-class), MAZDA 2 and 3 with 1.4 and 1.5 l diesel engine

2169-27	27	082339
----------------	----	--------

- **6-point s 32 mm**
OPEL Astra, Corsa, VW Passat, AUDI

2169-32	32	082346
----------------	----	--------

- **6-point s 36 mm**
e.g. for MERCEDES-BENZ C- and E-classes, engine 116 MB, 100 D Transporter, BMW and OPEL Vectra B DI 16 V, VW Lupo 1.2 TDi, model year 1999, Touareg TDi

2169-36	36	086566
----------------	----	--------

125	1/2"	
------------	------	--



- For the operation of Purflux oil filters
- 12.5 = 1/2" resp. outside hexagon 24 mm

Oil Filter Wrenches

125	1/2"	
------------	------	--

HAZET No.	mm	mm	EAN-No. 4000896+
-----------	----	----	------------------

- **s 66 mm groove profile (6 grooves)**
- RENAULT Clio, Twingo, Kangoo, FIAT Punto, Stilo, Brava, Bravo with 1,2 I, LANCIA Y 1.2 I, MAZDA 323, 626, MX 3, Xedos, MITSUBISHI Colt, Carisma, Space Star, NISSAN Micra, Primera, Serena, TOYOTA Yaris, Starlet, MR 2, Corolla, Carina, Avensis

2169-66	24	77	100217
----------------	----	----	--------

- **s 76 mm groove profile (6 grooves)**
- AUDI A3, A4, A6, CITROEN C5, Xantia, FIAT Brava, Bravo, Punto, Tipo, FORD Fiesta, Escort, MERCEDES-BENZ passenger cars and Sprinter, PEUGEOT 106, 206, 306, 406, RENAULT Clio, Kangoo, Megane, Laguna, Rapid, HONDA Accord 1600, 1800, Civic since 1986, Civic Shuttle, Prelude, CRX, OPEL Astra G/F, Corsa A/B, Vectra A/B, Calibra, Zafira, Frontera, VW Golf III + IV, Polo, Passat, Sharan, SEAT Alhambra, Toledo, Leon, Cordoba, SKODA Octavia
for **fuel filters**
RENAULT Espace, Laguna, R19
VOLVO S 40 and V 40 until 1999

2169-76	24	85	100309
----------------	----	----	--------

- **s 86 mm groove profile (6 grooves)**
- ALFA 145, 146, 156 1.9 JTD, 156 2.4 JTD
VW Golf III, Sharan, Vento, Passat until 1996 with TDi engine, Lupo, Polo 1.7 SDi
AUDI A4, A6 until 1996 with TDi engine 85 KW/115 PS, FIAT Bravo and Brava 1.9 JTD
RENAULT Clio/R 19 with 1.4 - 1.7 amd 1.8, Megane 1.4 and 2.0, Rapid with 1.9 D, Laguna, Safrane and Espace III with 2.1 D, SEAT Alhambra 1.9 TDi, Arosa 1.7 SDi
for **fuel filters**
MERCEDES-BENZ Vito, Sprinter, A-class (type 168), C-class (type 202), E-class (type 210)

2169-86	24	97	100323
----------------	----	----	--------

- **s 96 mm groove profile (6 grooves)**
- VW Golf III, Passat since 1996 with 1.9 TDi engine
AUDI A4 and A6 since 1996 with 1.9 TDi engine
RENAULT Laguna, Safrane und Espace 2.2 TD, MITSUBISHI Lancer 2.0 D, Space Wagon 2.0 TD, L 200 2.5 D and TD
SEAT Cordoba, Ibiza, Toledo 1.9 TDi engine, model year 1996
VOLVO S 70 2.5 TDi model year 1997, S 80 2.5 TDi model year 1998

2169-96	24	108	100200
----------------	----	-----	--------

Universal Strap Wrench

E	
----------	--



- Especially for oil filter, generator and round screwed connections
- Cotton textile tape, rubber coated
- Nonskidding
- Chrome-Vanadium
- Surface chrome-plated

HAZET No.	mm	EAN-No. 4000896+
-----------	----	------------------

2170	160	013371
-------------	-----	--------

Werkzeuge für Raum und Zeit! Tools for Air and Space



Oil Filter Wrenches



- For the operation of oil filters e.g. as assembly tool for oil and fuel filters on commercial vehicles MAN
- Adjustable steel strip
- DBGM – German registered utility model

HAZET No.	Ø mm	EAN-No. 4000896+
-----------	------	------------------

□ drive 12.5 = 1/2"

2171-1	80-110	013418
--------	--------	--------

with lever

2171-2	75-110	013432
--------	--------	--------



- For removing oil filters even in areas with restricted access
- Adjustable by turning knob or hexagon 13 mm
- Replaceable steel strip

HAZET No.	Ø mm	EAN-No. 4000896+
-----------	------	------------------

2171-5	65-105	013449
--------	--------	--------

2171-6	105-150	013456
--------	---------	--------

Oil Filter Chain Wrench



- For removing oil filters and for the operation of the granulates cartridge on commercial vehicles with compressed air dryers
- Even in areas with restricted access

- With chain
- □ drive 12.5 = 1/2"
- Special steel
- DBGM – German registered utility model

HAZET No.	Ø mm	EAN-No. 4000896+
-----------	------	------------------

2171-8	50-150	013463
--------	--------	--------

Oil Filter Wrench

10 3/8" (E)



- For oil filters in areas with restricted access
- Left-hand and right-hand operation
- Universal application
- □ drive 10 = 3/8" resp. ● 19 mm
- Special steel
- Surface galvanized

HAZET No.	sb mm	EAN-No. 4000896+
-----------	-------	------------------

2172	65-115	013470
------	--------	--------

Motor Components – Clutch

Clutch-Centering Mandrels



- For fast and exact clutch plate centering on vehicles **with clutch guide bearing**
- For passenger cars and small commercial vehicles
- Infinitely variable
- Special steel
- Surface chrome-plated

HAZET No.	Ø mm	EAN-No. 4000896+
-----------	------	------------------

2173-1	15-19,0	013524
--------	---------	--------

2173-2	20-26,6	013555
--------	---------	--------

Clutch-Centering Mandrel Set



HAZET No.	EAN-No. 4000896+
-----------	------------------

2173/2 K	013586
----------	--------

Clutch Centering Tool



- For the **correct aligning and installation of clutch plates to the pressure plate**
- Fast and easy installing
- No need to center the clutch plate by the needle bearing
- Also for cars **without** clutch guide
- For passenger cars and small commercial vehicles
- With 2 collets:
 - size 1 = 15-21 mm Ø
 - size 2 = 21-28 mm Ø
- Plastic with metal clamping screw

HAZET No.	EAN-No. 4000896+
-----------	------------------

2174	013609
------	--------

General Workshop Equipment

Machinist's Vice



Special steel drop-forged

HAZET No.	sb mm	b mm	EAN-No. 4000896+
-----------	-------	------	------------------

2175 N	100	90	013685
--------	-----	----	--------

Wooden liner for 2175 N with fixing kit for fixing the vice on work benches or tool trolleys

2175 N-11	-	-	013692
-----------	---	---	--------

Telescopic Tube Cutter



- For tube cutting
- Cutting range 6 to 35 mm outside-Ø
- Consistently narrow working radius of 123 mm
- Forward feed is synchronous to rotation
- 2 grooved rollers for close-to flare cuts
- With retracting deburrer stored in frame
- Spare cutter wheel in handle

HAZET No.	l mm	Ø mm	EAN-No. 4000896+
-----------	------	------	------------------

2180-2	145	6-35	013715
--------	-----	------	--------

Cutter wheel for copper for 2180-2

2180-021	-	-	061860
----------	---	---	--------

Tube Cutters



- For tubes made of copper, brass, light metal and PVC rigid
- Automatic forward feeding due to disk springs
- Cutting range outside Ø: 3 – 16 mm
- Special casting
- Surface lacquered

HAZET No.	l mm	Ø mm	EAN-No. 4000896+
-----------	------	------	------------------

2181-1	52	3-16	064557
--------	----	------	--------

Spare cutter wheel

2181-011	-	-	072903
----------	---	---	--------

Tube Cutters



- For tubes made of copper, brass, light metal and PVC rigid
- Cutting range 3.5 mm up to 10 mm outside-Ø
- up to 2.5 mm wall thickness and 10 mm outside-Ø
- Ratcheting

HAZET No.	l mm	Ø mm	EAN-No. 4000896+
-----------	------	------	------------------

2182-1	115	10	061952
--------	-----	----	--------

Spare cutter wheel

2182-01	-	-	076734
---------	---	---	--------

Swedish Pattern Wrenches



- Self-locking, safe and firm grip even of smooth tubes due to 3-point tensioning
- Application on nuts and tubes, 25 mm = 1", 37 mm = 1.1/2", 50 mm = 2"
- Swedish pattern
- Handles with double-T-section profile
- Slim, s-shaped jaws
- Bent (45°)
- Toothing offset against direction of rotation
- Chrome-Vanadium all-steel drop-forged
- Induction hardened toothing
- Surface powder coated polished jaws
- DIN 5234

HAZET No.	l mm	sb mm	EAN-No. 4000896+
-----------	------	-------	------------------

2183-1	320	35	013746
--------	-----	----	--------

2183-1,5	416	46	013753
----------	-----	----	--------

2183-2	535	65	013760
--------	-----	----	--------

Chassis – Brakes

Tube Flaring Tool Set



290 x 173 x 50

- For metal tubes and pipes with a wall thickness of 0.7 and 1.0 mm
- For open (F) or folded (E) flares according to DIN 74234, normal 90° and 180° flares as well as tubes per inch
- For flares on rolled and drawn tubes
- With replaceable hinged gripping jaws made of special steel
- Special casting
- Surface lacquered
- In sheet steel box with plastic insert

Note: For plastic covered brake linings use HAZET 2193/4K!

HAZET No.	Ø	EAN-No. 4000896+
2191-12 K		013890

contents:

 2181-1 2191
2191-1 2 3 4 5 6 8 9 10 90

2191/12 K	013890
-----------	--------

contents:

 2181-1 2191
2191 A-1 3 4 6 8 10 2191-2 90

2191 A/10 K	013968
-------------	--------

contents:

 2181-1 2191
2191 A-1 3 4 6 8 10
2191-1 2 3 4 5 6 8 9 10 90

2191 MA/18 K	013982
--------------	--------

Tube Flaring Unit



for tubes with a wall thickness of 0.7 and 1.0 mm

HAZET No.	Ø	EAN-No. 4000896+
2191	4,75-10 mm / 3/16-3/8"	013784

Gripping Jaws



for "E" and "F" flares, burnished

HAZET No.	Ø	EAN-No. 4000896+
2191-1	4,75, 5, 6, 8, 9, 10 mm	013791
2191 A-1	3/16, 1/4, 5/16, 3/8" A	013906

Pipe Deburring Tool

 for tube deburring, for tubes with outside- ϕ 4-32 mm = 5/32"-1.1/4"

HAZET No.	Ø	EAN-No. 4000896+
2191-2	4-32 mm / 5/32-1.1/4" A	013814

Base Blocks



for "E", "F" and "180° flares

HAZET No.	Ø	EAN-No. 4000896+
2191-3	4,75- 10 mm	013821
2191 A-3	3/16-3/8"	013920

Thrust Blocks



for "E" and "F" flares according to DIN 74234

HAZET No.	Ø	EAN-No. 4000896+
2191- 4	4,75 mm	013838
2191- 5	5 mm	013845
2191- 6	6 mm	013852
2191- 8	8 mm	013869
2191- 9	9 mm	013876
2191-10	10 mm	013807
2191 A- 4	3/16" A	013937
2191 A- 6	1/4" A	013944
2191 A- 8	3/16" A	013951
2191 A-10	3/8" A	013913

90°-Thrust Block

 for "E" and normal flares
4.75 up to 10 mm resp. 3/16" up to 3/8"

HAZET No.	Ø	EAN-No. 4000896+
2191-90	4,75-10 mm / 3/16-3/8" A	013883

Tube Flaring Tool Set



290 x 173 x 50

- Especially for **plastic-coated brake lines** 4.75 mm ϕ
- On VW-AUDI, except AUDI 100 and 200 with antilocking system
- In sheet metal box with plastic insert

Tube Flaring Tool Set



contents:

2181-1 2193 2193-1 2

HAZET No.	EAN-No. 4000896+
2193/4 K	014088

Tube Flaring Unit



- Light-weight and handy
- May be clamped into a vice, also allows manual operation under vehicles

HAZET No.	Ø	EAN-No. 4000896+
2193	4,75 mm	014002

Thrust Block

with dowel pin

HAZET No.	EAN-No. 4000896+
2193/02	014071

Bending Tool

 for bending brake lines 4.75 mm ϕ

HAZET No.	Ø	EAN-No. 4000896+
2193-1	4,75 mm	014057

Tube Deburring Tool



for inside and outside deburring

HAZET No.	Ø	EAN-No. 4000896+
2193-2	4,75 mm	014064

Cartridge Wrench

125 1/2



- For loosening the granulates cartridge on commercial vehicles with **compressed air dryer** e.g. on MERCEDES-BENZ and MAN
- drive 12.5 = 1/2"
- Special steel
- Surface burnished

MAN-No. 8099606-0307

HAZET No.	Ø max. mm min.	EAN-No. 4000896+
2195	140 90	014101

HAZET Screwdriver Bits and Accessories

✓ **Special steel for excessive use**

✓ **High-precision, close-tolerance fabrication of tips and edges**

✓ **Always the correct profile:**



✓ **For electric and pneumatic screw driving machines as well as for manual operation**



Please note...

... our extensive range of Screwdrivers from page 42 on

Screwdriver Bits



- High-precision, close-tolerance fabrication of tips and edges
- For excessive use
- For electric and pneumatic **screw driving machines (screwdrivers)** as well as for manual operation
- Special steel

For inside hexagon screws

- 6.3 = 1/4"
- DIN 7426-C 6.3

HAZET No.	S mm	l mm	EAN-No. 4000896+
2204-1,5	1,5	25	014132
2204-2	2,0	25	014149
2204-2,5	2,5	25	014156
2204-3	3,0	25	014163
2204-4	4,0	25	014170
2204-5	5,0	25	014187
2204-6	6,0	25	014200
2204-8	8,0	25	014217



- For inside hexagon screws
- **With ball hex** angular movement min. 10°
- 6.3 = 1/4"
- Hexagon according to DIN 3126-C, ISO 1173-C

HAZET No.	S mm	l mm	EAN-No. 4000896+
2204 KK-5	5	100	014224
2204 KK-6	6	100	014231
2204 KK-7	7	100	014248



- For inside hexagon screws
- 8 = 5/16"
- DIN 7426-C 8

HAZET No.	S mm	l mm	EAN-No. 4000896+
2206- 5	5	30	014262
2206- 6	6	30	014279
2206- 8	8	30	014286
2206-10	10	30	014255

Screwdriver Bits



- For inside hexagon screws
- **With ball hex** angular movement min. 15°
- 8 = 5/16"
- Hexagon according to DIN 3126-C, ISO 1173-C

HAZET No.	S mm	l mm	EAN-No. 4000896+
2206 KK- 8	8	100	014316
2206 KK-10	10	100	014293
2206 KK-12	12	100	014309



- For slotted screws
- 6.3 = 1/4"
- DIN 3127-C 6.3

HAZET No.	mm	mm	l mm	EAN-No. 4000896+
2208- 4	0,5	4,0	25	014361
2208- 6	0,6	4,5	25	014385
2208- 8	0,8	5,5	25	014408
2208- 9	1,0	6,0	25	014415
2208-10	1,2	6,5	25	014323
2208-11	1,2	8,0	25	014347
2208-12	1,6	8,0	25	014354



- For slotted screws
- 8 = 5/16"
- DIN 3127-C 8, ISO 2351

HAZET No.	mm	mm	l mm	EAN-No. 4000896+
2210- 8	0,8	5,5	41	014477
2210- 9	1,0	5,5	41	014484
2210-10	1,2	6,5	41	014422
2210-11	1,2	8,0	41	014439
2210-12	1,6	8,0	41	014446
2210-13	1,6	10,0	41	014453
2210-14	2,0	12,0	41	014460



- For screws with internal serration (XZN)
- 6.3 = 1/4"
- DIN 65254

HAZET No.	M	l mm	EAN-No. 4000896+
2211-4	4	25	056392
2211-5	5	25	056408

Screwdriver Bits



- For screws with internal serration (XZN)
- 8 = 5/16"
- DIN 65254

HAZET No.	M	l mm	EAN-No. 4000896+
2212- 6	6	35	056415
2212- 8	8	35	056422
2212-10	10	35	056439



- For TRI-WING® screws
- 6.3 = 1/4"

HAZET No.	EAN-No. 4000896+
2213-0	078721
2213-1	078738
2213-2	078745
2213-3	078752
2213-4	078769
2213-5	078776
2213-6	078783



- For Phillips-recess screws
- Tough-hard for threaded screws
- 6.3 = 1/4"
- DIN 3128-C 6.3

+ = reinforced design

HAZET No.	l mm	EAN-No. 4000896+
2215-PH 1	25	014491
2215-PH 2	25	014521
2215-PH 3 +	32	014569
2215-PH 4 +	32	014583

very hard, e.g. for sheet metal screws

2215-PH 1 a	25	014507
2215-PH 2 a	25	014538



- For Phillips-Recess screws
- **Long style**
- Tough-hard for threaded screws
- 6.3 = 1/4"
- Hexagon according to DIN 3126-C, ISO 1173-C

HAZET No.	l mm	EAN-No. 4000896+
2215 Lg-PH 2	50	014590

Screwdriver Bits



- For Pozidriv screws
- ● 6.3 = 1/4"
- Hexagon according to DIN 3126-C, ISO 1173-C
- + = reinforced design

HAZET No.	l mm	EAN-No. 4000896+
2216-PZ 1	25	014606
2216-PZ 2	25	014613
2216-PZ 3	25	014620
2216-PZ 4 +	32	014637



- For Pozidriv screws
- **Long style**
- ● 6.3 = 1/4"
- Hexagon according to DIN 3126-C, ISO 1173-C

HAZET No.	l mm	EAN-No. 4000896+
2216 Lg-PZ 2	50	014644



- For Phillips-Recess screws
- ● 8 = 5/16"
- DIN 3128-C 8
- + = reinforced design

HAZET No.	l mm	EAN-No. 4000896+
2217-PH 1	32	014651
2217-PH 2	32	014668
2217-PH 3	32	014682
2217-PH 4 +	38	014699



- For Pozidriv screws
- ● 8 = 5/16"
- Hexagon according to DIN 3126-C, ISO 1173-C
- + = reinforced design

HAZET No.	l mm	EAN-No. 4000896+
2218-PZ 1	32	014705
2218-PZ 2	32	014712
2218-PZ 3	32	014729
2218-PZ 4 +	38	014736



- For TORQ-SET® screws
- ● 6.3 = 1/4"

HAZET No.	l mm	EAN-No. 4000896+
2221- 0	25	078806
2221- 1	25	078813
2221- 2	25	078820
2221- 3	25	078837
2221- 4	25	078844
2221- 5	25	078851
2221- 6	25	078868
2221- 8	25	078875
2221-10	25	078882



- For TORQ-SET® screws
- ● 8 = 5/16"

HAZET No.	EAN-No. 4000896+
2222-1/4	078899
2222-5/16	078905
2222-3/8	078912

TORX® Screwdriver Bits



- For inside TORX® screws
- ● 6.3 = 1/4"
- Hexagon according to DIN 3126-C, ISO 1173-C

HAZET No.	mm	l mm	EAN-No. 4000896+
2223-T 6	1,67	25	015023
2223-T 7	1,99	25	015030
2223-T 8	2,31	25	015047
2223-T 9	2,50	25	015054
2223-T 10	2,74	25	014866
2223-T 15	3,27	25	014880
2223-T 20	3,86	25	014903
2223-T 25	4,43	25	014934
2223-T 27	4,99	25	014958
2223-T 30	5,52	25	014972
2223-T 40	6,65	25	014996



- For inside TORX® screws
- Long style
- ● 6.3 = 1/4"
- For screws at the seat frame cover plate and for adjusting the steel sliding roof
- Hexagon according to DIN 3126-C, ISO 1173-C

HAZET No.	mm	l mm	EAN-No. 4000896+
BMW 3 and 5 series			
2223 Lg-T 25	4,43	65	015061
AUDI 80 and 90 since 1988			
2223 S Lg-T 25	4,43	110	015108



- For inside TORX® screws
- Long style
- ● 6.3 = 1/4"
- For installing and removing the **airbag unit** e.g. MERCEDES-BENZ, VW-AUDI, OPEL, PORSCHE
- Hexagon according to DIN 3126-C, ISO 1173-C

HAZET No.	mm	l mm	EAN-No. 4000896+
2223 Lg-T 30	5,52	70	015092



- For tamper resistant TORX® screws (inside TORX® screws with pin)
- With front bore hole
- ● 6.3 = 1/4"
- T 30 H for sensor screw (airbag BMW)
- Hexagon according to DIN 3126-C, ISO 1173-C

HAZET No.	mm	l mm	EAN-No. 4000896+
2223-T 7 H	1,99	25	058082
2223-T 8 H	2,31	25	058099
2223-T 9 H	2,50	25	058105
2223-T 10 H	2,74	25	014873
2223-T 15 H	3,27	25	014897
2223-T 20 H	3,86	25	014910
2223-T 25 H	4,43	25	014941
2223-T 27 H	4,99	25	014965
2223-T 30 H	5,52	25	014989
2223-T 40 H	6,65	25	015009

TORX® Screwdriver Bits



- For inside TORX® screws
- ● 8 = 5/16"
- Hexagon according to DIN 3126-C, ISO 1173-C

HAZET No.	mm	l mm	EAN-No. 4000896+
2224-T 25	4,43	35	015115
2224-T 27	4,99	35	015122
2224-T 30	5,52	35	015139
2224-T 40	6,65	35	015160
2224-T 45	7,82	35	015177
2224-T 50	8,83	35	015184
2224-T 55	11,22	35	015191



- For tamper resistant TORX® screws (inside TORX® screws with pin)
- With front bore hole
- ● 8 = 5/16"
- Hexagon according to DIN 3126-C, ISO 1173-C

HAZET No.	mm	l mm	EAN-No. 4000896+
2224-T 25 H	4,43	35	049936
2224-T 27 H	4,99	35	049943
2224-T 30 H	5,52	35	049950
2224-T 40 H	6,65	35	049967
2224-T 45 H	7,82	35	049974
2224-T 50 H	8,83	35	049981
2224-T 55 H	11,22	35	049998



- For inside TORX® screws
- **Long style**
- ● 6.3 = 1/4"
- Hexagon according to DIN 3126-C, ISO 1173-C

HAZET No.	mm	l mm	EAN-No. 4000896+
2224 S Lg-T 25	4,43	100	015221
2224 S Lg-T 27	4,99	100	015238
2224 S Lg-T 30	5,52	100	015245
2224 S Lg-T 40	6,65	100	015252
2224 S Lg-T 45	7,82	100	015269
2224 S Lg-T 50	8,83	100	015283
2224 S Lg-T 55	11,22	100	015306



- For tamper resistant TORX® screws (inside TORX® screws with pin)
- With front bore hole
- **Long style**
- ● 8 = 5/16"
- Hexagon according to DIN 3126-C, ISO 1173-C

HAZET No.	mm	l mm	EAN-No. 4000896+
2224 S Lg-T 25 H	4,43	100	050000
2224 S Lg-T 27 H	4,99	100	050017
2224 S Lg-T 30 H	5,52	100	050024
2224 S Lg-T 40 H	6,65	100	050031
2224 S Lg-T 45 H	7,82	100	050048
2224 S Lg-T 50 H	8,83	100	050055
2224 S Lg-T 55 H	11,22	100	050062

5-Star Screwdriver Bits



- For the operation of inside 5-star screws with pin
- T 20 H: Application on screws at the MERCEDES-BENZ Atego and Actros plug-in pump as well as VW air flow sensor
- \bullet 6.3 = $\frac{1}{4}$ "

HAZET No.	EAN-No. 4000896+
-----------	------------------

Components

2225-10 H	097043
2225-15 H	097050
2225-20 H	097067
2225-25 H	097074
2225-27 H	097081
2225-30 H	097098
2225-40 H	097104

Assortment with holder

- Bit holder with magnetic bit retention
- Practical and space-saving bit storage in handle
- 7 parts

contents:
2225-10H 15H 20H 25H 27H 30H 2262

2225/7 H	097333
----------	--------

Adapters



- For screw driving machines
- With inside square and inside hexagon tool insert, with clamp ring
- Chrome-Vanadium
- Surface burnished
- DIN 7427-A

HAZET No.	\circ mm	\square	EAN-No. 4000896+
2230 S-1	6,3 = $\frac{1}{4}$ "	6,3 = $\frac{1}{4}$ "	015320
2230 S-2	6,3 = $\frac{1}{4}$ "	10 = $\frac{3}{8}$ "	015337
2230 S-3	8 = $\frac{5}{16}$ "	10 = $\frac{3}{8}$ "	015344
2230 S-4	6,3 = $\frac{1}{4}$ "	12,5 = $\frac{1}{2}$ "	015351
2230 S-5	8 = $\frac{5}{16}$ "	12,5 = $\frac{1}{2}$ "	015368



- For the connection of sockets
- \square 6.3 = $\frac{1}{4}$ " (DIN 3120 – A 6.3) and operating tools with \circ drive 6.3 = $\frac{1}{4}$ ", (DIN 3126-E 6.3)

- With ball retention
- Chrome-Vanadium
- Surface burnished

HAZET No.	l mm	EAN-No. 4000896+
2238-1	50	063741



- With permanent magnet ensuring a safe grip of bits and screws
- Chrome-Vanadium
- Brass socket galvanized
- Hexagon drive burnished

HAZET No.	l mm	EAN-No. 4000896+
-----------	------	------------------

- For drilling machines and cordless screwdrivers
- \circ D 6.3 = $\frac{1}{4}$ " \bullet C 6.3 mm
- DIN 7427-B connection according to DIN 3126, ISO 1173

2239-1	60	015375
--------	----	--------

Adapters

HAZET No.	l mm	EAN-No. 4000896+
-----------	------	------------------

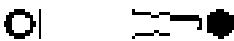

- For screw driving machines,
- \circ D 6.3 = $\frac{1}{4}$ " \bullet A 5.5 mm
- e.g. AEG, Bosch, Holz Her, Metabo

- DIN 7427-B connection according to DIN 3126, ISO 1173

2239-2	72	015382
--------	----	--------

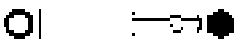

- For screw driving machines,
- \circ D 6.3 = $\frac{1}{4}$ " \bullet E 6.3 mm
- e.g. AEG, Atlas-Copco, Black&Decker, Bosch

- DIN 7427-B connection according to DIN 3126, ISO 1173

2239-3	75	015399
--------	----	--------



- For screw driving machines,
- \circ D 6.3 = $\frac{1}{4}$ " \bullet G 7 mm, outside flat end, form G
- e.g. Fein

- Connection according to DIN 3126, ISO 1173

2239-4	74	015405
--------	----	--------

Screwdriver Bits Sets



36 parts

contents:

850-5 5,5 6 7 8 9
10 11 12 13 14
2204-2 2,5 3 4 5 6 8
2208-4 6 8 10
2215-PH1 PH2 2216-PZ1 PZ2
2223-T 10H T 15H T 20H
T 25H T 30H T 40H
2238-1 2239-3 2264 2304

HAZET No.	EAN-No. 4000896+
-----------	------------------

2200/36	063734
---------	--------



- Assortment for slotted screws, Phillips-Recess and Pozidriv screws

- In plastic box
- With PUR foam insert

Screwdriver Bits Sets

103 parts

2208-6	8	10	10 each	
2215-PH 1	PH 2	PH 3	PH 4	10 each
2216-PZ 1	PZ 2	PZ 3	10 each	
2239-1			3 each	

HAZET No.	EAN-No. 4000896+
-----------	------------------

2240/103	015412
----------	--------

Adapters



- For manual operation
- With inside square and outside hexagon drive
- With ball clamping (annular spring and ball)
- Chrome-Vanadium
- Surface chrome-plated

HAZET No.	\circ	\square	l mm	EAN-No. 4000896+
-----------	---------	-----------	------	------------------

2250-1	6,3 = $\frac{1}{4}$ "	6,3 = $\frac{1}{4}$ "	23,5	015443
--------	-----------------------	-----------------------	------	--------

2250-2	6,3 = $\frac{1}{4}$ "	10 = $\frac{3}{8}$ "	30,0	015450
--------	-----------------------	----------------------	------	--------

2250-3	8 = $\frac{5}{16}$ "	10 = $\frac{3}{8}$ "	31,0	015474
--------	----------------------	----------------------	------	--------

2250-4	6,3 = $\frac{1}{4}$ "	12,5 = $\frac{1}{2}$ "	35,0	015504
--------	-----------------------	------------------------	------	--------

2250-5	8 = $\frac{5}{16}$ "	12,5 = $\frac{1}{2}$ "	36,0	015511
--------	----------------------	------------------------	------	--------

Holder with Screwdriver Bit



- For removing the driver's and co-driver's doors on VW-Golf 3 since 1993
- Holder made of Chrome-Vanadium, chrome-plated (2251-1), bit special steel (2224-T 45)
- \circ drive 8 = $\frac{5}{16}$ "
- Set with 2 parts

contents:

2224-T 45 2251-1

HAZET No.	l mm	EAN-No. 4000896+
-----------	------	------------------

2251-1/2	310	015542
----------	-----	--------

Holder only

2251-1	310	015535
--------	-----	--------

Bit Holder for Screwdriver Bits



- \circ drive 6.3 = $\frac{1}{4}$ "
- T-handle
- Magnetic bit retention
- Aluminium

HAZET No.	\circ	l mm	EAN-No. 4000896+
-----------	---------	------	------------------

2253	6,3 = $\frac{1}{4}$ "	135	015559
------	-----------------------	-----	--------



- \circ drive 6.3 = $\frac{1}{4}$ "
- Magnetic bit retention

HAZET No.	\circ	l mm	EAN-No. 4000896+
-----------	---------	------	------------------

2255	6,3 = $\frac{1}{4}$ "	190	015566
------	-----------------------	-----	--------

Bit Holder for Screwdriver Bits



- \varnothing drive 6.3 = 1/4"
- Flexible shaft
- In conjunction with Screwdriver Bit HAZET 4525-2, for carburettor adjustment (CO) in engines of series "A" and "L" without air cleaner removal, on all NISSAN cars, except Stanza (T11), 280ZX, 280ZX-T (S130)

HAZET No.	l ₂ mm	EAN-No. 4000896+
2255-1	312	050079



- \varnothing drive 6.3 = 1/4"
- **Magazine handle** with bits 6.3 = 1/4" and adapter for drills and cordless screwdrivers, may be fixed also in the plastic magazine (screwdriver handle)

HAZET No.	l ₂ mm	EAN-No. 4000896+
-----------	-------------------	------------------

6 parts
contents:
2208-6 8 2215-PH1 PH2
2239-1

2260/6	147,5	015740
--------	-------	--------

10 parts
contents:
2208-4 6 8 10
2215-PH1 PH2
2216-PZ1 PZ2
2239-1

2260/10	147,5	015573
---------	-------	--------

10 parts
contents:
2223-T9 T10 T15 T20 T25
T27 T30 T40
2239-1

2260/10 T	147,5	015702
-----------	-------	--------



- \varnothing drive 6.3 = 1/4"
- **Magazine handle** empty
- Magnetic bit retention
- Short style

HAZET No.	l ₂ mm	EAN-No. 4000896+
2261	90	015795



- \varnothing drive 6.3 = 1/4"
- **Magazine handle**, empty
- Magnetic bit retention

HAZET No.	l ₂ mm	EAN-No. 4000896+
-----------	-------------------	------------------

long style		
2262	200	015825

extra long style		
2263	300	015856

Bit Holder for Screwdriver Bits



- \varnothing drive 6.3 = 1/4"
- **Magazine handle**
- Magnetic bit retention
- Short style
- **Bit set**, 7 parts, in magazine handle

contents:
2208-6 8 9 11
2215-PH1 PH2
2261

HAZET No.	l ₂ mm	EAN-No. 4000896+
2261/7	90	015801

Bit Holders with Screwdriver Bits



- \varnothing drive 6.3 = 1/4"
- **Magazine handle**
- Magnetic bit retention
- Long style
- **Bit set**, 7 parts, in handle

contents:
2208-6 8 9 11
2215-PH1 PH2
2262

HAZET No.	l ₂ mm	EAN-No. 4000896+
2262/7	200	015832

- \varnothing drive 6.3 = 1/4"
- **Magazine handle**
- Magnetic bit retention
- Extra long style
- **Bit set**, 7 parts, in handle

contents:
2208-6 8 9 11
2215-PH1 PH2
2263

HAZET No.	l ₂ mm	EAN-No. 4000896+
2263/7	300	015863

Reversible Ratchets for Bits

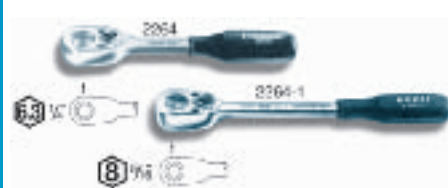

- **For screwdriver bits**
- Chrome-Vanadium
- Surface chrome-plated, polished

HAZET No.	l ₂ mm	EAN-No. 4000896+
-----------	-------------------	------------------

\varnothing drive 6.3 = 1/4",
20 teeth

2264	115	015887
------	-----	--------

\varnothing drive 8 = 5/16",
30 teeth

2264-1	200	015894
--------	-----	--------



Repair Set for shift lever

consisting of: shift lever, screws, ball, compression spring for 863, 863 G 863 P, 863 PC, 863 Q, 863 S, 863 ST, 2264

863 P/5	038589
---------	--------

Repair Set for shift lever

consisting of: shift lever, screws, ball, compression spring for 8816 G, 8816 GK, 8816 P, 8816 S, 8816 ST 2264-1, 6110 CT, 6110-1 CT, 6111-1 CT, 6114-1 CT, 6115-1 CT 6402-1, 6402-1 S, 6408-1

8816 P/5	042227
----------	--------

Repair Set for ratchet wheel 6.3 = 1/4" \varnothing
consisting of: ratchet wheel, pawl, shift lever, screws, ball, compression spring for 2264

2264/7	015917
--------	--------

Repair Set for ratchet wheel 6.3 = 1/4" \varnothing
consisting of: ratchet wheel, pawl, shift lever, screws, ball, compression spring for 2264-1, 6408-1

2264-1/7	015900
----------	--------



Reversible Ratchets for Bits



- For screwdriver bits
 - drive 6.3 = 1/4"
 - and ○ 8 = 5/16"
- With magnetic bit retention
- With ratchet function, reversible
- Special steel
- Surface bright chrome-plated

HAZET No.	EAN-No. 4000896+
-----------	------------------

flat style

2265-1	079636
--------	--------

offset style

2265-2	076253
--------	--------

Bit Screwdriver



- ○ drive 6.3 = 1/4"
- **Free-Running** trinamic® handle
- Right-hand and left-hand rotation
- Operation is possible in fixed position
- Magazine with bits
- Blade with permanent handle
- Knurled shank ensures a good grip allows easy and non-skidding turning
- Blade with hex bolster
- 7 parts

contents:
2208-4 8
2215-PH1 PH2
2216-PZ1 PZ2
2266

HAZET No.	l mm	EAN-No. 4000896+
-----------	------	------------------

2266/7	236	015931
--------	-----	--------

Bit Screwdriver, empty

2266	236	015924
------	-----	--------

Impact Screwdriver



- For impact loosening and tightening of screws
- ○ drive 8 = 5/16"

HAZET No.	l mm	EAN-No. 4000896+
-----------	------	------------------

2272	165	015979
------	-----	--------

Impact Screwdriver Set (Bits)



225 x 123 x 46

- ○ drive 8 = 5/16"
- In sheet metal box
- With plastic insert
- 17 parts

contents:

2206-5 6 8 10
2210-8 9 10 12 14
2217-PH2 PH3 PH4
2224-T30 T40 T45 T50
2272

HAZET No.	EAN-No. 4000896+
-----------	------------------

2272/17	015986
---------	--------

Impact Screwdriver



- For impact loosening and tightening of screws
- Torque values up to 120 Nm
- ○ drive 10 = 3/8"

HAZET No.	l mm	EAN-No. 4000896+
-----------	------	------------------

2301	140	016013
------	-----	--------

Adapters



- For the connection of sockets with square drive according to DIN 3120 and operating tools with hexagon drive
- Chrome-Vanadium
- Surface burnished

HAZET No.	■	●	EAN-No. 4000896+
-----------	---	---	------------------

2304	6,3 = 1/4"	6,3 = 1/4"	016020
------	------------	------------	--------

2305	6,3 = 1/4"	8 = 5/16"	016037
------	------------	-----------	--------

2305-1	10 = 3/8"	8 = 5/16"	016044
--------	-----------	-----------	--------

2306	10 = 3/8"	10 = 3/8"	016051
------	-----------	-----------	--------

2311	12,5 = 1/2"	10 = 3/8"	016068
------	-------------	-----------	--------



Screwdriver Bits



- For slotted screws
- ○ drive 10 = 3/8"
- Special steel

HAZET No.	⌀ mm	l mm	l mm	EAN-No. 4000896+
2321- 1	1,0	7	40	016075
2321- 3	1,2	9	40	016105
2321- 5	1,4	9	40	016112
2321- 7	1,6	10	40	016129
2321- 9	2,0	12	40	016136
2321-11	1,5	13	40	016082
2321-13	2,5	16	40	016099



- For Phillips-Recess screws
- ○ drive 10 = 3/8"
- Special steel

HAZET No.	l mm	EAN-No. 4000896+
2326-PH 2	35	016143
2326-PH 3	35	016150
2326-PH 4	35	016167



- For inside hexagon screws
- ○ drive 10 = 3/8"
- Special steel

HAZET No.	S mm	l mm	EAN-No. 4000896+
2331- 5	5	35	016181
2331- 6	6	35	016198
2331- 8	8	35	016204
2331-10	10	35	016174

Impact Screwdriver Set (Bits)



225 x 123 x 46

- For loosening and tightening screws with high torque values
- ○ drive 10 = 3/8"
- In sheet metal box
- With plastic insert
- Special steel
- 15 parts

contents:

2301 2306 2311
2321-1 5 7 9 11
2326-PH2 PH3 PH4
2331-5 6 8 10

HAZET No.	EAN-No. 4000896+
-----------	------------------

2351/15	016211
---------	--------

HAZET – Specialty Tools for famous car manufacturers



Tool Assortment



assortment with 45 parts,
for motorcycles

- contents:
 600N-8 10 11 13 14 15 17 19 22
 630-27 x32
 760N-2
 801K-55 801K-PH2
 803-55 80 803-PH1 PH2
 880-8 10 11 12 13 14 15 17 19 21 22
 8815 8816P 8820 8821-5 10
 1802-11 1841a-11 1952-35
 2100-02 025 03 04 05 06 08
 2140-5 2147



Tool Kit



assortment with 19 parts
for HARLEY-DAVIDSON-motorcycles
in linen texture roll

- contents:
 450N A-3/8 x 7/16 VKH 1/2 x 9/16 VKH
 600N-10
 625AK-3/4 x 15/16H
 630AK-5/8 x 19/16H
 760N-1
 2100A-1/8 5/32 3/16 7/32 1/4 5/16 3/8
 2115-T27 2208-10
 2215-PH1 PH3
 2262
 82062 HARLEY

HAZET
No.

EAN-No.
4000896+

0-2450/45

000289

HAZET
No.

EAN-No.
4000896+

2460/19

050185

Tool Assortment

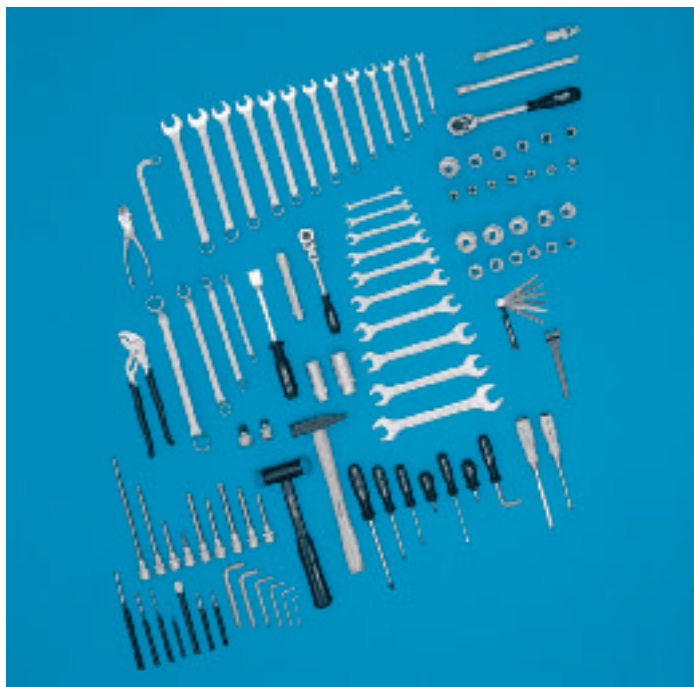

VOLKSWAGEN-AUDI

Classification to vehicles: pages 171-190

assortment with 100 parts
for VOLKSWAGEN – AUDI



- contents:
- 450N-6x 7 8x 9 10x11 12x13 14x15
16x17 18x19 20x22 21x23 24x27
 - 600N-8 10 11 12 13 14 15
16 17 18 19 20 21
 - 630-8x10 13x15 17x19 22x24
 - 731-5 745-1 746-1
 - 748a-2 748b-4 6 748c-8
 - 760N-2
 - 801K-80 801K-PH2
 - 803-40 803-PH1 PH2 PH3
 - 815-1 2 824
 - 8816GK
 - 900-12 17 18 19 20 21
22 24 27 30 32
 - 900Z-8 9 10 11 12 13 14
15 16 17 18 19 30
 - 916SP 917-5 918-10 920
 - 985-12 17
 - 986Lg-5 7 10
 - 986SLg-8
 - 990Lg-8 990SLg-10 12
 - 1802-2 1953-35
 - 2100-025 04 05 06 08 10
 - 2140-5 2147
 - 2505-2 2584
 - 2584-1 2587
 - 2593-1
 - 4555N 4555-3 4561

HAZET No.	EAN-No. 4000896+
0-2500/100	000296

Plastic Inserts

HAZET plastic drawer insert
suitable for the VOLKSWAGEN-AUDI Tool Assortment 0-2500/100
for the Tool Trolley *Assistant*

- contents:
- 161-24 PL 27 PL 28 PL 32 PL 49 PL
 - 2500-1 PL 2 PL 3 PL 4 PL 5 PL

HAZET No.	EAN-No. 4000896+
2500 PL/10	079803

Tool Assortment



assortment with 109 parts
for VOLKSWAGEN-AUDI
in HAZET plastic drawer inserts



- contents:
- 450N-6x 7 8x 9 10x11 12x13 14x15
16x18 17x19 20x22 24x27 30x32
 - 600N-6 7 8 9 10 11 12 13 14
15 16 17 18 19 21 22 24
 - 630-6x 7 8x 9 10x11 12x13 14x15 16x17
18x19 20x22 21x23 24x26 25x28 27x32
 - 731-5 745-1 746-1
 - 748a-2 748b-2 748b-6 748c-8
 - 760N-2
 - 801-30 40 55 65 80
 - 801-PH1 PH2 PH3
 - 801K-55 801K-PH2
 - 824
 - 8816 F
 - 900-10 11 12 13 14 15 16 17 18
19 20 21 22 24 27 30 32
 - 900Z-8 9 19 30
 - 916SP 917-5 918-10 920 919-1 5
 - 985-12 17
 - 986Lg-10 986SLg-8
 - 990SLg-10 12
 - 1802-22 1841 A-22
 - 1953-35
 - 2105Lg-015 02 025 03 04 05 06 08 10
 - 2140-5
 - 2505-2 2587
 - 4555N 4561

HAZET No.	EAN-No. 4000896+
0-2500/109	100705

Screwdriver Sockets



- For screws with internal serration XZN
- □ drive 12.5 = 1/2"
- Handy and milled
- Blades made of special steel

HAZET No.	M	l ₁ mm	l ₂ mm	d mm	EAN-No. 4000896+
990-18	18	45	85	26	108916

For installing and removing the wheel bearing/hub unit at the rear axle
– AUDI A 3 since 2004
– VW Touran since 2004

Spark Plug Wrench

10 3/8 (E)



- For spark plugs with 20.8 / 13/16" width across
- With holding rubber
- Adjustable in length from 137.5 mm to 157.5 and 197.5 mm
- □ drive 10 = 3/8"
- Special steel
- Surface chrome-plated

HAZET No.	Ø mm	l mm	EAN-No. 4000896+
2505-2	20,8	137,5	016266

Reversible Ratchet



10 3/8

(E)

- Short style
- **With hinge joint**
- ■ drive 10 = 3/8"
- Ratchet wheel 30 teeth
- Chrome-Vanadium
- Surface chrome-plated, polished

HAZET No.	l mm	EAN-No. 4000896+
8816 GK	218	042142

Spark Plug Wrench

10 3/8 (E)



- For **16 mm (5/8")** spark plugs
- □ drive 10 = 3/8"
- With rubber ply
- Application: VW 16 valve engines, MAZDA 626, 2.0l, 16 valves with DOHC engine since 1987, MAZDA 323, 1.6l and 1.9l since 1989, MX 5, 1.6l, since 1990
- Special steel
- Surface mat chrome-plated

HAZET No.	Ø mm	l mm	EAN-No. 4000896+
2506	16 (5/8)	270	016297

Extractor

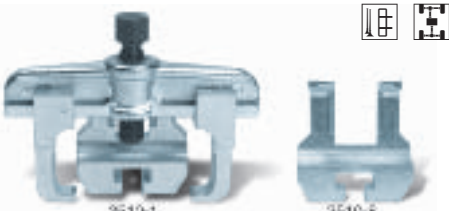

2510-1

2510-2

- **For the extraction of camshaft pulleys**
- Application: 5 and 6 spokes camshaft pulleys on 4- or 6-cyl. engines TDi, engines V6 and V8, AUDI A 4, A 6, A 8

Extractor

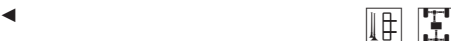

HAZET No.	EAN-No. 4000896+
2510-1	071913
Extraction Hook for Extractor 2510-1 For camshaft pulleys with 5 spokes on VW/AUDI V8 petrol engines	
2510-8	082063

Forcing Screws

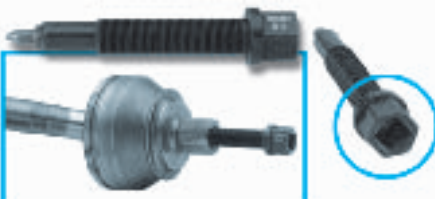

- For separating by force the outer homocinetic joint of the axle drive shaft on VW-AUDI, SEAT or SKODA e.g. when replacing axle collars
- Quick and problem-free working even on pasted homocinetic joints
- The outside hexagon ≤ 21 mm as well as the inside square 12.5 = 1/2" allow flexible application of different operating tools

HAZET No.	l mm	EAN-No. 4000896+
2515-1	108	087549
2515-2	120	087556
2teiliger Satz: 2515-1 2		
2515/2		097647

Extractor



- **For removing the front grille** of the VW vans (Transporter) since 1991
- With T-handle

HAZET No.	EAN-No. 4000896+
2520-1	075218

Dismounting Tools



2525-1

2525-2

- For removing the **airbag at the steering wheel, to be used in pairs**
- Protected by design patent

HAZET No.	EAN-No. 4000896+
for VW Golf 4, New Beetle, SEAT since 1999	
2525-1	067732
Set with 2 parts: 2 x 2525-1	
2525-1/2	081257
for VW Passat B 5, Polo, Lupo, AUDI A4 and A6	
2525-2	067367
Set with 2 parts: 2 x 2525-2	
2525-2/2	081264

Ball Tip Screwdriver Sockets



- For inside hexagon screws
- Blade made of special steel

HAZET No.	S mm	l mm	EAN-No. 4000896+
• For the oil pan on 5-cyl. diesel engines of T4 transporter			
• □ drive 10 = 3/8"			
2527-5	5	227	016303
• For knock sensor on V6 engine, AUDI 100 since 12/90, AUDI 80 since 7/92			
• □ drive 12.5 = 1/2"			
2527-8	8	238	016310

Flex Head Socket Wrenches



- For the **oil pan**
- □ drive 10 = 3/8"
- With ball joint and T-handle
- Chrome-Vanadium
- Surface chrome-plated

HAZET No.	Ø mm	l mm	EAN-No. 4000896+
2528-10	10	250	016327



- For **generator holder, cooling pump, fuel pump**
- □ drive 10 = 3/8"
- With ball joint and T-handle
- Chrome-Vanadium
- Surface chrome-plated

HAZET No.	Ø mm	l mm	EAN-No. 4000896+
2528-13	13	201	016334



- For **10 mm glow plugs**
- □ drive 10 = 3/8"
- With universal joint
- With ball clamping (annular spring and ball)
- Application: VW-AUDI diesel direct injection engine TDi and MERCEDES-BENZ CDI
- Chrome-Vanadium
- Surface chrome-plated

HAZET No.	Ø mm	l mm	EAN-No. 4000896+
2530	10	140	016341

Brass Mandrel



- **For driving bushings, bearings, bolts, etc. in and out**

HAZET No.	Ø mm	l mm	EAN-No. 4000896+
2534	20	200	016365

Retainer with exchangeable pins



- For installing and removing the toothed belt pulleys at the camshaft, crankshaft and fuel injection pump on VW Lupo, Polo, New Beetle, Golf, Caddy, Bora, Touran, Sharan, Transporter
- AUDI A2, A3, A4, A6, TT
- Special steel
- Surface chrome-plated
- Handle dip-coated, black

HAZET No.	l mm	EAN-No. 4000896+
2540-1	695	110407

Screwdriver with Internal Serration



- For screws with internal serration (XZN)
- **Screws at the door lock**
- Application: AUDI TT, VW Golf 4, Passat B5, Lupo, New Beetle, Bora

HAZET No.	M	l ₁ mm	l ₂ mm	EAN-No. 4000896+
2565-4	4	125	215	072484

Slotted Screwdriver



- For **slotted round nuts** on lighting switches, pull switches and fan switches, etc.
- VW-AUDI, BMW and oldtimer
- 6.5 mm boring, 37 mm deep
- Chrome-Vanadium
- Surface chrome-plated

HAZET No.	l mm	EAN-No. 4000896+
2566-2	109	016396

Oil Service Wrench



- For 17 mm oil filler and oil drain plugs at VW-AUDI gearboxes
- For 19 mm drain plug at the VW-AUDI oil pan
- Chrome-Vanadium
- Surface chrome-plated

HAZET No.	S mm	l mm	EAN-No. 4000896+
2567-1	17x19	251	016402

Oil Service Socket



- For screws with internal serration (XZN) with internal hole for pivots
- For **oil drain plug on gearbox**
AUDI A2, A3, A4, A6, VW Passat B5, Golf 4, LT T4, T5
PORSCHE Boxster shift gear
FORD Galaxy 1.9 TDi with 6-speed gear box
- □ drive 12.5 = 1/2"
- Chrome-Vanadium
- Surface chrome-plated

HAZET No.	M	l mm	EAN-No. 4000896+
2567-16	16	60	016419

Guide Pin Driver Sets



- For **centering the cylinder head gasket** on the motor unit
- On VW-AUDI passenger cars and commercial vehicles
- Special steel
- Surface burnished
- 5 parts: Extractor Pin with 2 Guide Pins each

HAZET No.	l ₂ mm	EAN-No. 4000896+
2570/5	277	016457

Extractor Pin with M 8 left-handed thread without guide pin

2570	277	016426
------	-----	--------

Guide Pin

outside thread ϕ M 11 x 1.5

2570-07	30	016433
---------	----	--------

outside thread ϕ M 12

2570-09	40	016440
---------	----	--------



- For **centering the cylinder head gasket** on the motor unit
- On VW-AUDI, SEAT, SKODA
- Special steel
- Surface burnished
- 5 parts: Extractor Pin with 2 Guide Pins each

HAZET No.	l ₁ mm	l ₂ mm	EAN-No. 4000896+
2571/5	165	277	058242

Extractor Pin for guide pin 2571-9 -10

2571-1	165	277	058211
--------	-----	-----	--------

Guide Pin

thread M 9 x 125, for centering the cylinder head gasket on oblique engine blocks at VW-AUDI, SKODA, SEAT-engines new construction series

2571-9	-	30	058228
--------	---	----	--------

Guide Pin thread M 10

long style especially for VW New Beetle

2571-10 A	-	60	074860
-----------	---	----	--------

6-Point Socket



- For screwed connections at the cooling pump
- □ drive 6.3 = 1/4"
- With ball clamping (annular spring and ball)
- Size 10 mm
- Application: Polo and Golf, with engines of 0.9 l, 1.05 l, 1.1 l and 1.3 l, also OPEL Kadett 1.2 l and Corsa

HAZET No.	S mm	l mm	EAN-No. 4000896+
2572	10	33	016464

Depressors



- For preloading bucket tappets on 4-cyl. engines up to 1982 (in conjunction with Valve Shim Pliers HAZET 2599)
- Working surface hardened
- Chrome-Vanadium
- Surface burnished

HAZET No.	l mm	EAN-No. 4000896+
2574	245	016471



- For preloading bucket tappets on 4-cyl. engines since 1983 5- and 6-cyl. engines (in conjunction with Valve Shim Pliers HAZET 2599)
- Working surface hardened
- Chrome-Vanadium
- Surface burnished

HAZET No.	l mm	EAN-No. 4000896+
2574-1	260	016488

Seal Pusher



for pressing on valve stem seals on VW-AUDI engines

HAZET No.	l mm	EAN-No. 4000896+
2577	134	016914

Valve Spring Tensioner



- For pressing down valve springs e.g. when changing the valve stem seals on VW-AUDI **bucket tappet engines 1.3 - 1.8 l with stud bolts M 8**
- Replaceable plastic thrust piece
- Chrome-Vanadium
- Surface chrome-plated
- DBGM - German registered utility model

HAZET No.	l mm	EAN-No. 4000896+
2577-2	405	016945

Retainers



in conjunction with Valve Spring Tensioner 2577-2 for stud bolts M 7 and/or M 8

HAZET No.	l mm	EAN-No. 4000896+
-----------	------	------------------

for stud bolts M 7

2577-207/2	60	016976
------------	----	--------

for stud bolts M 8

2577-208/2	60	016990
------------	----	--------

Screwdriver Socket



- For the operation of the new **Polydrive-cylinder head screws on VW-AUDI engines**
- drive 12.5 = 1/2"

HAZET No.	l ₁ mm	l ₂ mm	EAN-No. 4000896+
-----------	-------------------	-------------------	------------------

2579-9	130	168	086931
--------	-----	-----	--------

TORX® Sockets



- For the operation of outside TORX® screws on the **cylinder head** of AUDI V6-engines
- drive 12.5 = 1/2"
- Long style
- Chrome-Vanadium
- Surface chrome-plated

HAZET No.	l mm	mm	EAN-No. 4000896+
-----------	------	----	------------------

2580-E 14	190	12,90	017003
-----------	-----	-------	--------



- For the operation of outside TORX® screws on the **cylinder head** of AUDI 80 and 100 with V6-engines. Especially AUDI 80 V6 with antilocking system
- drive 12.5 = 1/2"
- Chrome-Vanadium
- Surface chrome-plated

HAZET No.	l mm	mm	EAN-No. 4000896+
-----------	------	----	------------------

2581-E 14	91	12,90	017010
-----------	----	-------	--------

Brake Adjusting Lever



- For adjusting of **drum brake shoes** with excenter
- For adjusting hand brakes with excenter
- Chrome-Vanadium
- Surface chrome-plated

HAZET No.	l mm	EAN-No. 4000896+
-----------	------	------------------

2582	304	017027
------	-----	--------

6-Point Socket



- For adjusting of torsion bars
 - installing of brake pressure regulators
 - removing of wheel bearings on VW transporter T4
- drive 12.5 = 1/2"
- Chrome-Vanadium
- Surface mat chrome-plated

HAZET No.	S mm	l mm	EAN-No. 4000896+
-----------	------	------	------------------

2583	27	140	017034
------	----	-----	--------

Screwdriver Sockets



- For inside hexagon screws
- drive 12.5 = 1/2"
- Blades made of special steel

HAZET No.	S mm	l mm	EAN-No. 4000896+
-----------	------	------	------------------

Screwed connections on joint flanges
VW-Passat, AUDI 80

2584	6	70	017041
------	---	----	--------

for intake pipe AUDI 200 5-cyl. Turbo

2584-1	6	248	017058
--------	---	-----	--------



- For inside hexagon screws
- For induction pipe on VW-AUDI 5-cyl. diesel engines and transporter T4
- drive 10 = 3/8"
- Blades made of special steel

HAZET No.	S mm	l mm	EAN-No. 4000896+
-----------	------	------	------------------

2584-2	6	100	017065
--------	---	-----	--------



- For inside hexagon screws
- For induction pipe on VW-AUDI 5-cyl. diesel engines and transporter T4
- drive 10 = 3/8"
- Blades made of special steel

HAZET No.	S mm	l mm	EAN-No. 4000896+
-----------	------	------	------------------

2584-3	6	108	103645
--------	---	-----	--------

Spring Vice

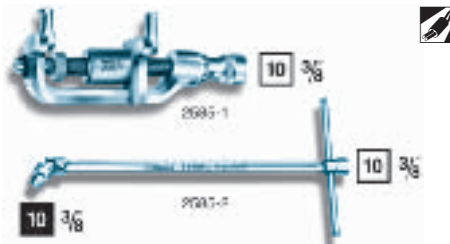

- For the **steel clamps** at the ball flange on VW **exhaust systems**
- Application: VW transporter T4 4-cyl. engine, Golf III, Jetta model years 1984-1992
- drive 10 = 3/8"
- Drop-forged
- Chrome-Vanadium
- Surface chrome-plated

Spring Vice



HAZET No.	SW max. mm	l mm	EAN-No. 4000896+
-----------	------------	------	------------------

Set with 2 parts:
Spring Vice 2585-1 and T-Handle 2585-2

2585/2	77	140/340	017102
--------	----	---------	--------

Spring Vice

2585-1	77	140	017089
--------	----	-----	--------

T-Handle with hinge joint

2585-2	–	340	017096
--------	---	-----	--------

Taper Key Set

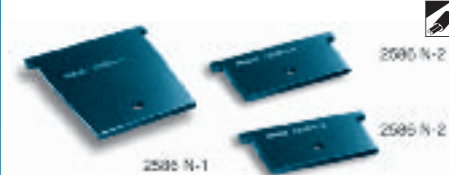

- For the **steel clamps** at the ball flange on VW **exhaust systems**
- Application: VW transporter T4 4-cyl. engine, Golf III, Jetta model years 1984-1992
- Special steel

HAZET No.	EAN-No. 4000896+
-----------	------------------

Set with 3 parts
1 x 2586 N-1 and 2 x 2586 N-2

2586 N/3	017133
----------	--------

Taper Keys

2586 N-1	017119
----------	--------

2586 N-2	017126
----------	--------

Double-Pin Wrenches



- For adjusting of the toothed belt at the tensioning pulley
- On 1.6 l VW diesel engine VW Transporter T3 (up to 1991), Golf, Jetta, Passat, AUDI 80
- Offset design
- Distance of pins 18 mm, pin- \varnothing 2.9 mm
- Special steel

HAZET No.	l mm	EAN-No. 4000896+
-----------	------	------------------

2587	140	017140
------	-----	--------



- For adjusting of the toothed belt at the tensioning pulley
- VW-Polo since 1995 (4-cyl.)
AUDI A4 since 1995 (4-cyl.)
AUDI 100 since 1991 (5-cyl.)
- Distance of pins 18 mm, pin- \varnothing 3 mm
- Special steel
- Surface mat chrome-plated

HAZET No.	l mm	EAN-No. 4000896+
-----------	------	------------------

2587-1	250	053476
--------	-----	--------

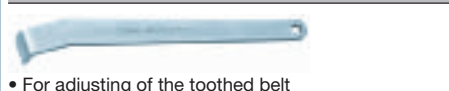

- For adjusting of the toothed belt at the tensioning pulley
- VW Golf 3, 4, AUDI A 3, SKODA Octavia
- Distance of pins 18 mm, pin- \varnothing 3 mm
- 15° offset
- Special steel
- Surface mat chrome-plated

HAZET No.	EAN-No. 4000896+
-----------	------------------

2587-2	072439
--------	--------

Idler Pulley Wrench



- For adjusting of the toothed belt at the automatic tensioning pulley
- Especially for VW Polo Diesel, AUDI 100 since 1991, AUDI A6 with 2.5 l TDi engine
- s 32 mm
- Special steel
- Surface mat chrome-plated, handle plastic coated

HAZET No.	l mm	EAN-No. 4000896+
2587-32	177	053285

Tool Set for Toothed Belt Changing



- For toothed belt changing e.g. on **VW pump jet engines** since 1999
- Application of the tool set ensures that the arrested components are tightly fixed during toothed belt changing or motor maintenance work

HAZET No.	EAN-No. 4000896+
2588/3	087761

Set with 3 parts:
2588-1 2 3

2588/3	087761
--------	--------

Crankshaft Fixing Device for crankshaft arresting

2588-1	087730
--------	--------

Locking Plate for the tensioning pulley arresting

2588-2	087747
--------	--------

Arresting Pin for the arresting of the camshaft pulley

2588-3	087754
--------	--------

Camshaft Locking Tool



- For locking the camshaft pulleys when changing the toothed belt
- Engine repairs on 4-valve, 4-cylinder injection engines VW Lupo since 1999, Polo since 1995, Caddy since 1996, Polo Classic, Variant since 1996, New Beetle 1.4 l since 1999, Golf 1.4 l, 1.6 l since 1998, Bora 1.4 l, 1.6 l since 1999
- Special steel

HAZET No.	EAN-No. 4000896+
2588-4	110391

Driving Tool for Tensioning Device

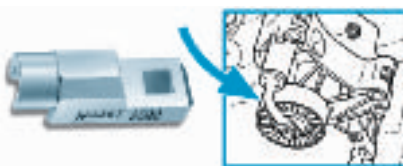

- For **operating the tensioning device** when changing the V-ribbed belt on VW Polo, Golf and Passat, AUDI since 1991
- Special steel
- Surface chrome-plated

HAZET No.	EAN-No. 4000896+
2590-1	053711

Special 6-Point Socket



- For **installing and removing the V-belt pulley** at the generator on VW transporter T4 since 1991, Golf 3/Vento since 1992, Passat since 1988, Corrado since 1989, AUDI 80 since 1992, AUDI 100 since 1991
- 24 mm outside hexagon drive
- With 12 mm bore hole
- Chrome-Vanadium
- Surface chrome-plated

HAZET No.	S mm	l mm	EAN-No. 4000896+
2590-24	24	44	017157

12-Point Socket



- For turbo charger –screwed connection– exhaust pipe on Passat Diesel 1.6 l since 1988
- s 12 mm
- **With hinge joint**
- □ drive 12.5 = 1/2"
- Chrome-Vanadium
- Surface chrome-plated

HAZET No.	l mm	EAN-No. 4000896+
2590 GZ-12	65	017164

Ignition Adjustment Wrench



- For the fastening nuts on ignition distributor
- Chrome-Vanadium
- Surface chrome-plated handle plastic coated

HAZET No.	S mm	l mm	EAN-No. 4000896+
2591	13	453	017171

Adapter (internal serration/XZN)



For installing or removing the **V-ribbed belt** at the **generator**, especially on VW Golf 3, Vento, Passat diesel 1.6 l and AUDI A 3

HAZET No.	S mm	Ø mm	l mm	EAN-No. 4000896+
2592	19,6	17	30	057443

Hex Head Wrench



- As retainer for installing and removing the **front spring struts**
- Chrome-Vanadium
- Surface bright nickel-plated
- Plastic handle

HAZET No.	S mm	l mm	EAN-No. 4000896+
2593-1	7	150	017188

Drive Nuts



- For the operation of **shock absorber screw connections** on VW and AUDI vehicles
- □ drive 22 mm, b = breadth of pins
- Chrome-Vanadium
- Surface chrome-plated

HAZET No.	B mm	Ø mm	EAN-No. 4000896+
-----------	------	------	------------------

for rear axle Golf 1 Cabriolet, Scirocco, Caddy

2593-2	3,5	10,5	017201
--------	-----	------	--------

for front axle POLO model year 1982

2593-3	3,5	12,5	017249
--------	-----	------	--------

for front axle Golf 2, 3, Jetta, Vento, Passat, AUDI 80

2593-4	5,0	15,5	017263
--------	-----	------	--------

Set, 3 parts: 2593-2 -3 -4

2593/3	-	-	017300
--------	---	---	--------

6-Point Socket



- For **installing and removing the front strut units** on VW-Polo since 1981, Derby since 1983, Polo Coupé
- In conjunction with HAZET 2593-1
- □ drive 12.5 = 1/2"
- Chrome-Vanadium
- Surface chrome-plated

HAZET No.	S mm	l mm	EAN-No. 4000896+
2593-19	19	85	017195

12-Point Socket



- For **installing and removing the front strut units** on VW-Golf 2 and Jetta since 1987, Golf 3 and Vento since 1993, Passat since 1988
- In conjunction with HAZET 2593-1
- □ drive 12.5 = 1/2"
- Chrome-Vanadium
- Surface chrome-plated

HAZET No.	S mm	l mm	EAN-No. 4000896+
2593-21	21	82	017218

6-Point Socket



- For installing and removing the front strut unit on VW-Golf up to 1988, Jetta up to 1987, Scirocco, Caddy, Passat, Santana, AUDI 80, Golf 3 and Vento since 1993, Passat since 1988, Corrado, AUDI 100 and 200, AUDI-Coupé, AUDI Quattro
- In conjunction with HAZET 2593-1
- □ drive 12.5 = 1/2"
- Chrome-Vanadium
- Surface chrome-plated

HAZET No.	S mm	l mm	EAN-No. 4000896+
2593-22	22	85	017225

Open End Wrench



- As retainer when installing and removing the rear **shock absorbers** on VW transporter T4, model year 1991
- MERCEDES-BENZ, for the **counter nut of the oil separator** on commercial vehicles with engine OM364A, OM364LA, 611D, 614D, 711D, 714D, 811D, 814D, 814DA
- Chrome-Vanadium
- Surface chrome-plated

HAZET No.	S mm	l mm	EAN-No. 4000896+
2593-50	50	300	017287

6-Point Socket



- For installing and removing the rear strut units on VW Passat, Santana, AUDI 100, 200
- □ drive 12.5 = 1/2"
- Chrome-Vanadium
- Surface chrome-plated

HAZET No.	S mm	O mm	l mm	EAN-No. 4000896+
2593 Lg-17	17	6,1 x 8,1	160	017317

Retainer



- For installing and removing the rear **strut units** and front **shock absorbers**
- Chrome-Vanadium
- Surface chrome-plated

HAZET No.	O mm	l mm	EAN-No. 4000896+
2594	5,1 x 8,1	6,1 x 8,1	198 017324

Bit Holder, bent



- For installing and removing the front doors on VW Golf 3 and Vento since 1993 (screwed connection door hinges), and for door alignment
- With square connection 9 x 12 mm
- With TORX® Bit T 45 (HAZET 2597-01)
- Chrome-Vanadium
- Surface chrome-plated

Removing:
in conjunction with Tool Holder HAZET 6396,

Installing:
with Torque Wrench HAZET 6290-1 CT – please consider VW torque regulations – see also HAZET 2251-1/2

HAZET No.	mm	l mm	EAN-No. 4000896+
2597	7,82	95	017379
Screwdriver Bit TORX® T 45 for 2597			
2597-01	7,82	18	017386

Screwdriver Bit



- For door alignment as well as installing and removing the driver's and co-driver's doors on VW Golf 4, Passat B5, SEAT Leon in conjunction with Bit Holder 2597
- For screws with internal serration (XZN) M 10

HAZET No.	M	l mm	EAN-No. 4000896+
2597-02	10	21	066667

TORX® Offset Screwdriver



- For the operation of **hinge screws T 45** when installing, removing or aligning **doors** on VW-Golf 3 and Vento model year 1993
- With plastic handle
- Special steel

HAZET No.	mm	l mm	EAN-No. 4000896+
2597-1	7,82	198 x 25	051915

Offset Screwdriver (internal serration)



- For operation of the **door hinge screws XZN M 10** on VW-Golf 4 and Passat B 5, SEAT Leon
- With plastic handle

HAZET No.	M	l mm	EAN-No. 4000896+
2597-10	10	198 x 25	063116

TORX® Screwdriver Socket



- For the operation of screws **of the upper door hinge**, when aligning or installing and removing the **driver's and co-driver's door** on VW Polo Classic, Polo Variant, Caddy since 1995 – consider VW torque regulations –
- With universal joint
- □ drive 10 = 3/8"

HAZET No.	mm	EAN-No. 4000896+
2597 G-T 45	7,82	057863

TORX® Screwdriver Bit



- For **installing and removing the driver's and co-driver's door** on VW-Golf 3, Vento since 1993
- **T 45** with special length
- ● 6.3 = 1/4"

In conjunction with Reversible Ratchet HAZET 2264 or Insert Reversible Ratchet HAZET 6408 and Torque Wrench HAZET 6290-1 CT – consider VW torque regulations – see also HAZET 2251-1/2

HAZET No.	mm	l mm	EAN-No. 4000896+
2597-T 45	7,82	25	017393

Valve Shim Pliers



- For valve shim replacement
- Application on VW 1.3i bucket tappet engines
- Tips hardened and tempered

HAZET No.	l mm	EAN-No. 4000896+
2599	265	017409

Tool Assortment

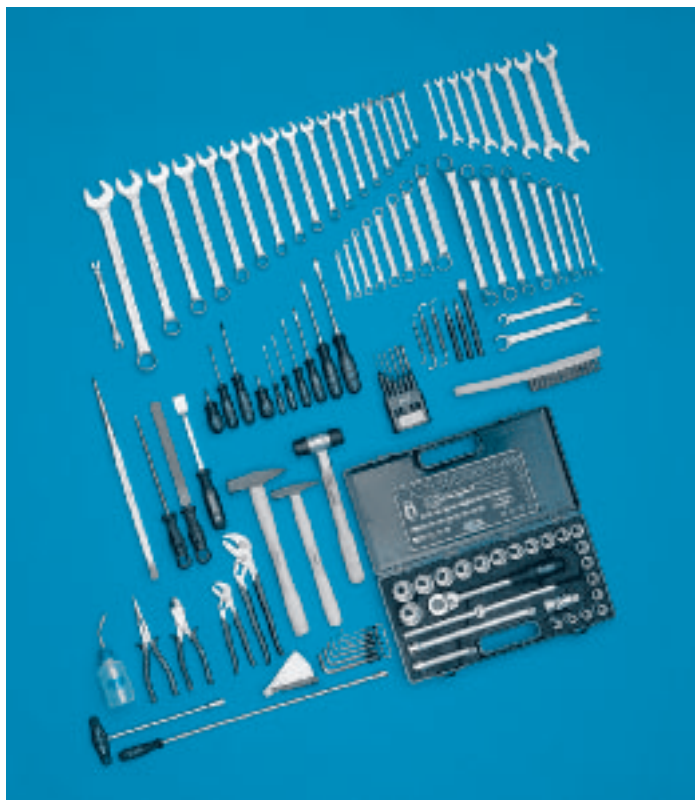

MERCEDES-BENZ

Classification to vehicles: pages 171-190



assortment with 117 parts for MERCEDES-BENZ passenger cars

contents:

428-10
 450 N-6x 7 8x 9 10x11 12x13
 14x15 16x17 18x19 21x22
 600 N-7 8 9 10 11 12 13 14 15
 16 17 18 19 21 22 24 27
 610 N-6x 7 8x 9 10x11 12x13
 14x15 16x17 18x19 21x22
 612 N-10x11
 612-12x14 16x18 17x19
 630-6x 7 8x 9 10x11 12x13 14x15
 16x17 18x19 20x22 21x23
 731-5 745a-2 746-2
 748b-2 3 4 5 6 8
 760 N-1 2
 801 K-55 801 K-PH2
 803-25 30 35 40 65 80
 803-PH 1 PH 2
 818-1 2
 819-PH1+PH2 824
 900-10 11 12 13 14 15 16 17 18 19 20
 21 22 23 24 26 27 28 30 32 34
 915 916 SP
 917-5 918-10 920
 1802-22 1841a-33
 1952-35 1976
 2100-03 04 05 06 08 10
 2120-8 2122-8 2130
 2140-2 5
 2147 2161 2165-2



Tool Assortment



assortment with 137 parts for MERCEDES-BENZ commercial vehicles

contents:

450 N-6x 7 8x 9 10x11 12x13 14x15
 16x17 18x19 21x22 24x27 30x32
 34x36
 600 N-7 8 9 10 11 12 13 14 15
 16 17 18 19 21 22 24 27 34
 610 N-6x 7 8x 9 10x11 12x13 14x15
 16x17 18x19 21x22 24x26 27x32
 612 N-10x11
 612-12x14 16x18 17x19
 630-6x7 8x10 8x9 10x11 12x13
 14x15 16x17 18x19 20x22 21x23
 24x26 25x28 27x32 30x34 36x41
 652
 730-6 8 746-2
 748b-2 3 4 5 6 8
 760 N-2 4 797
 801 K-55 801 K-PH2
 803-25 30 35 40 65 80
 803-PH 1 PH 2
 815-PH3 PH4 824
 900-10 11 12 13 14 15 16 17 18
 19 20 21 22 23 24 26 27 28
 30 32 34
 915 916 SP
 917-5 918-10 920
 1802-22 33 1841a-33
 1952-50 1976
 2100-02 03 04 05 06 07 08 09 10
 12 14 17 19 22
 2120-8 2122-8
 2130 2140-5 10
 2147 2161
 2165-1 3



Open End Wrench



- As retainer when installing and removing the rear **shock absorbers** on VW transporter T4, model year 1991
- MERCEDES-BENZ, for the **counter nut of the oil separator** on commercial vehicles with engine OM364A, OM364LA, 611D, 614D, 711D, 714D, 811D, 814D, 814DA
- Chrome-Vanadium
- Surface chrome-plated

HAZET No.	S mm	l mm	EAN-No. 4000896+
2593-50	50	300	017287

Mounting Lever



- For the operation of the **tensioning pulley** and for installing the **V-ribbed belt** on MERCEDES-BENZ type 168 (A-class)
- Surface chrome-plated, bolt burnished

HAZET No.	l mm	S mm	EAN-No. 4000896+
2714-1	600	15	076789

TORX® Screwdriver



- For installing and removing the **door handle** on MERCEDES-BENZ type 168 (A-class) and type 203 (C-class)
- With T-handle

HAZET No.	l ₁ mm	l ₂ mm	S mm	EAN-No. 4000896+
2715-T 20	200	225	3,86	071524

Socket



- For the operation of switches e.g. the reverse gear switch at the gear or the axles e.g. on MERCEDES BENZ commercial vehicles of the SK series, Actros, MAN commercial vehicles
- 27 mm **8-point special profile**
- Especially relieved
- □ drive 12,5 = 1/2"
- Chrome-Vanadium
- Surface chrome-plated

HAZET No.	l mm	EAN-No. 4000896+
2716-1	60	086405

12-Point Impact Socket



- For the operation of the spring buckle screws on commercial vehicles MERCEDES-BENZ, Actros series with pneumatic shock absorbers
- The Socket – **suitable for impact wrenches** – being especially adapted for areas with restricted access allows quick and safe working as well as the application of high forces
- 12-point
- Chrome-Vanadium special steel

HAZET No.	l mm	S mm	EAN-No. 4000896+
2717-27	112	27	086027

TORX® Insert Tool



- Especially for tightening the fixing screw of the left camshaft wheel on MERCEDES-BENZ engines M 112 (6-cyl.), C-, E- and S-classes – consider torque regulations of car manufacturer –
- With square connection 14 x 18
- For outside TORX® screws in conjunction with Torque Wrenches, e.g. HAZET 6291-1 CT
- Chrome-Vanadium
- Surface chrome-plated

HAZET No.	S mm	EAN-No. 4000896+
2718-E 18	16,70	057320

Box-End Wrench



- As retainer for the self-locking nut on the rubber bearing of the rear axle differential on MERCEDES-BENZ passenger cars
- Chrome-Vanadium
- Surface chrome-plated

HAZET No.	l mm	S mm	EAN-No. 4000896+
2719-17	211,5	17	060634

Box-End Insert Tools



- **With bore hole**
- For the operation of the front axle screws on MERCEDES-BENZ E-class, type 211 since 2002
- With square connection 14 x 18
- 20° offset
- Chrome-Vanadium
- Surface chrome-plated

HAZET No.	l mm	S mm	EAN-No. 4000896+
2720-21	65	21	100651

Box-End Insert Tools



With bore hole

- For the operation of the rear axle screws on MERCEDES-BENZ E-class, type 211 since 2002
- With square connection 14 x 18
- 20° offset
- Chrome-Vanadium
- Surface chrome-plated

HAZET No.	l ₁ mm	S mm	EAN-No. 4000896+
2720-E 18	59,1	16,70	100569

Pliers for Moulding



- For installing and removing the **fixing clamps of the chrome-moulding** on MERCEDES-BENZ C-, E- and S-class

HAZET No.	l mm	EAN-No. 4000896+
2724-1	208	060368

Lockring Pliers



H.I.T.S.

- For the application of **lockrings on shift linkage**, e.g. for installing and removing shift and automatic transmissions on MERCEDES-BENZ passenger cars
- Special steel

HAZET No.	l mm	EAN-No. 4000896+
2725	320	051809

Compressed Air Adapter

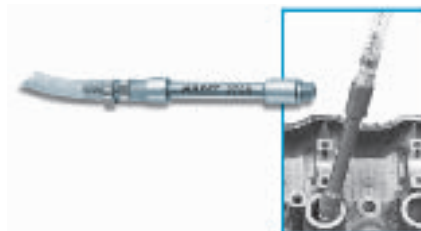

- For keeping installed valves raised when **installing and removing valve springs**, on MERCEDES-BENZ multi-valve engines e.g. when changing the valve stem seals
- With spark plug threads M 14 x 1.25, air coupling and air hose

HAZET No.	EAN-No. 4000896+
2728	053742

Assembly Tool



- For installing and removing fixing springs of the handle brake shoes on passenger cars with disk brakes
- With T-handle
- With guide groove

HAZET No.	l mm	EAN-No. 4000896+
2730	142	017423

Special Tool for MERCEDES-Star



- For installing and removing the Mercedes-Star at the engine hood S-class (W 140), E-class (W 124 since 1993), C-class (W 202)
- With T-handle
- Chrome-Vanadium
- Surface chrome-plated

HAZET No.	l mm	EAN-No. 4000896+
2735	170	017430

TORX® Screwdriver Socket with Universal Joint



- For the screws at the oil pump on MERCEDES-BENZ cars with engines type 129 S-class SL 280, SL 320 type 163 M-class ML 320 type 208 CLK, CLK 320 type 210 E-class E 240, E 280, E 320
- For inside TORX® screws T 50
- drive 10 = 3/8"

HAZET No.	mm	EAN-No. 4000896+
2739 G-T 50	8,83	072156

Screwdriver Socket with Universal Joint



- For inside hexagon screws on water pump – engines M 103, M 104 water hose connection – engines M 103, M 120 intake pipe – diesel engines M 601, M 603, M 604
- drive 10 = 3/8"

HAZET No.	S mm	l mm	EAN-No. 4000896+
2740	6	250	050093

12-Point Socket with Universal Joint

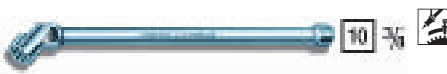

- For screwed connections at the fuel injection pump on type 615, 616
- With universal joint
- drive 10 = 3/8"

HAZET No.	S mm	l mm	EAN-No. 4000896+
2742-13	13	240	017447

Screwdriver Sockets

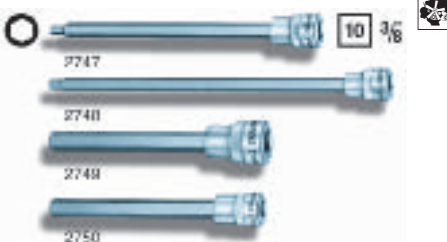

- For inside hexagon screws
- drive 10 = 3/8"
- For screws on engines
- Blades made of special steel

HAZET No.	S mm	l mm	EAN-No. 4000896+
2747	5	160	017461
2748	6	220	017478
2749	8	100	017485
2750	10	130	017492



- For screws on cylinder head and cardan shafts (screws with internal serration XZN)
- drive 12.5 = 1/2"

HAZET No.	M	l mm	EAN-No. 4000896+
2751	10	140	017508



- For screws with internal serration XZN on M 104 6-cyl., M 119 8-cyl., M 120 12-cyl.
- Blade made of special steel
- drive 12.5 = 1/2"

HAZET No.	M	l mm	EAN-No. 4000896+
2752	12	55	017522

Screwdriver Sockets



- For screws with internal serration (XZN) e.g. **balance wheel and vibration shock** on engines of commercial vehicles, 500 series since 12/95, 900 since 6/96
- drive 20 = 3/4" with locking pin

HAZET No.	M	EAN-No. 4000896+
2753	14	049929

Screwdriver Socket with Universal Joint



- For inside hexagon screws e.g. for installing and removing the starter
- With universal joint
- drive 12.5 = 1/2"

HAZET No.	S mm	l mm	EAN-No. 4000896+
2755	10	138	017539

6-Point Socket with Universal Joint



- For installing and removing standard gearboxes
- drive 12.5 = 1/2"

HAZET No.	S mm	l mm	EAN-No. 4000896+
2756-16	16	100	060399
2756-17	17	100	017553
2756-19	19	100	017577

Flare Nut Insert Tools



- For oil pressure tube on clutch operating cylinder of all standard gearboxes
- drive 10 = 3/8"

HAZET No.	S mm	l mm	EAN-No. 4000896+
2757-12	12	48	017591



- 12-Point Socket
- For the **screws at the injection lines** on MERCEDES-BENZ Sprinter
- 10 = 3/8"
- Chrome-Vanadium
- Surface chrome-plated

HAZET No.	S mm	l mm	EAN-No. 4000896+
2757-14	14	85	100637



- For the operation of **fuel line screws at the gasoline tank** type 124 E-class type 126 S-class type 129 S-class type 201 190
- drive 10 = 3/8"

HAZET No.	S mm	EAN-No. 4000896+
2757-22	22	069767

Cylinder Head Wrench



- For cylinder head screws on M 401, 404, 407-409, 421-424, 427, 428, 444, 447
- drive 12.5 = 1/2"

HAZET No.	S mm	l mm	EAN-No. 4000896+
2758-17	17	165	017614

12-Point Sockets



20 3/4"

- Reinforced design for working on commercial vehicles
- Chrome-Vanadium special steel
- □ drive 20 = 3/4"

HAZET No.	S mm	EAN-No. 4000896+
for cylinder head screws engine 400, 420		
2759-17	17	050680
for disk flywheel engine 300, 400		
2759-19	19	050697
for disk flywheel engine 1424 OM, 366 LA		
2759-22	22	071951

Oil Service Wrenches



- For oil filler plug on M 8 gearbox
- Chrome-Vanadium
- Surface chrome-plated

HAZET No.	S mm	l mm	EAN-No. 4000896+
Type 100, 110, 115, 116, 117, 615, 616, 617			
2760	14 x 17	237	017638
Type 102, 103, 104, 110, 115, 116, 117, 119, 120, 123			
2760-2	14 x 13	287	017652

Square Through-Plug



- For racing the engine during valve adjustment and valve timing on type 102, 103, 104, 110, 115, 116, 117, 119, 120, 123
- For Through-Plug Ratchet □ 12.5 = 1/2"

HAZET No.	l mm	EAN-No. 4000896+
2761	80	017683

Extension



- For screws in areas with restricted access e.g. at the starter, engine, gearbox
- □ drive 12.5 = 1/2"
- With pin locking device – only use sockets with lateral bore hole

HAZET No.	l mm	EAN-No. 4000896+
2762	575	017706

Valve Adjusting Wrenches



- For valve adjustment e.g. on type 100, 110, 114, 115, 123, 130
- In conjunction with HAZET Torque Wrench 6121-1 CT
- □ drive 12.5 = 1/2"

HAZET No.	S mm	l mm	EAN-No. 4000896+
2768-1	17	67	017768



- For valve adjustment on engines M 615 (200 D, 220 D) M 616 (240 D, 240 TD)
- In conjunction with HAZET 2769-3
- Both wrenches to be used together

HAZET No.	S mm	l mm	EAN-No. 4000896+
2769	14	225	017782
2769-1	14	160	017799

Valve Spring Retainer Wrench



- For valve adjustment
- Prevents rotation of the valve disk
- In conjunction with HAZET 2769, 2769-1

HAZET No.	S mm	l mm	EAN-No. 4000896+
2769-3	30	170	017805

Valve Adjusting Wrenches

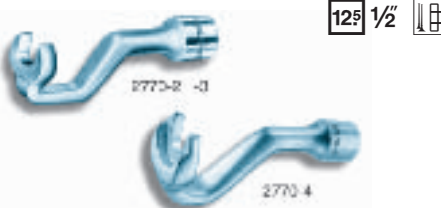

- For valve adjustment
- □ drive 12.5 = 1/2"

HAZET No.	Ø mm	l mm	EAN-No. 4000896+
2770-2	14	110	017843
2770-3	17	125	017867
2770-4	17	111	017874

- For valve adjustment without removing the valve springs on carburetor engines M 110

HAZET No.	S mm	l mm	EAN-No. 4000896+
2771	17	350	017881

Tension Chain



- For pressing out the drive shaft on MERCEDES-BENZ C-class 4matic, type 203
- Total length 216 mm

HAZET No.	EAN-No. 4000896+
2773-1	100606

Spark Plug Wrench

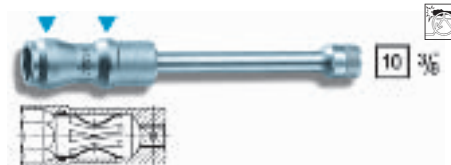

- Application on multi-valve engines M 104, M 119, M 120
- With fixing clamp
- With 2 outside guide collars
- □ drive 10 = 3/8"

HAZET No.	Ø mm	Ø"	EAN-No. 4000896+
2776	16	5/8	017935

Seal Puller



- For pressing on valve stem seals, Ø 7mm
- On MERCEDES-BENZ multi-valve engines M 104, M 119, M 120
- Plastic

HAZET No.	l mm	EAN-No. 4000896+
2777	160	050635

Shock Absorber Tool



- For the operation of the upper locking screw on shock absorbers
- Side insert 9 x 12 mm for the operation with e.g. HAZET Torque Wrench 6291-2 CT
- Retainer with s 13 mm outside hexagon drive
- Pivot profile Ø for taking the shock absorber piston rod
- Chrome-Vanadium
- Surface chrome-plated

HAZET No.	EAN-No. 4000896+
2780	053698

- s 17 mm inside hexagon drive for the operation of the union nut on model C, type 202 model E, type 210 model SLK, type 170

2780	053698
------	--------

- s 16 mm inside hexagon drive for the operation of the union nut on vehicles built after 1999 type 202 C-class type 210 E- class

2780-16	070886
---------	--------

Drive Nut



- For the operation of **shock absorber screw connections** on MERCEDES-BENZ type 203 (C-class since 2000)
- \bullet drive 22 mm, b = pin breadth
- Chrome-Vanadium
- Surface chrome-plated

HAZET No.	B mm	\varnothing mm	EAN-No. 4000896+
2780-1	2,65	14,1	082858

Open 6-Point Socket



- For the front pipe screwings at the MERCEDES-BENZ strut unit with pneumatic shock absorption E-class type 211
- Outside hexagon drive s 10 mm
- Chrome-Vanadium
- Surface chrome-plated

HAZET No.	S mm	l mm	EAN-No. 4000896+
2781-10	10	40	100644

Valve Retainer Ring Pliers



- For removing valve stem seals on multi-valve-engines
- Jaws hardened, longitudinally toothed
- Working area dip-insulated avoiding damages of the timing gear
- **Bent 25°**

HAZET No.	l mm	EAN-No. 4000896+
2791	241	018116



- For removing valve stem seals on multi-valve-engines
- Jaws hardened, longitudinally toothed
- Working area dip-insulated avoiding damages of the timing gear
- **Straight design**
- DBGM – German registered utility model

HAZET No.	l mm	EAN-No. 4000896+
2791-1	250	018123

Bit Holder with Bit



- For the screws at the tie rod/ hub carrier MERCEDES-BENZ C-class, type 202
- Chrome-Vanadium
- Bit made of special steel, steel grey

HAZET No.	M	l mm	EAN-No. 4000896+
2792-12	12	140	100613

Brake Spring Pliers



- For the **operation of the retaining springs at the drum brake linings** e.g. on MERCEDES-BENZ type 168, A-class, as well as on various French cars: RENAULT Clio, Twingo since 2003
- For the **new types** of retaining springs (form C and P)
- Jaws are especially formed according to the retaining springs

HAZET No.	l mm	EAN-No. 4000896+
2796-1	235	072330

Socket Set

10 3/8" (E)



- \square drive 10 = 3/8"
- In sheet metal box with plastic insert
- 18 parts

contents:
 880 Z-9 10 11 12 13
 14 15 17 19 22
 880-7 8
 8815 8816 P 8820
 8821-6 8 8858-1

HAZET No.	EAN-No. 4000896+
2800/18	018192

Tool Set

6.3 1/4" (E)

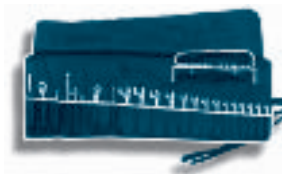

- \square drive 6.3 = 1/4"
- In plastic bag
- 35 parts

contents:
 440-3,5 4 4,5 5 5,5 6 7 8
 9 10 11 12 13 14
 760 N-1
 801 K-55 803 VDE-25
 850-4 4,5 5 5,5 6 7 8 9 10 11
 858-1 863 P
 865 866 U
 867-2 868
 869 8858-2

HAZET No.	EAN-No. 4000896+
2806/35	018222

MAN

Classification to vehicles: pages 171-190

TORX® Impact Socket



- For the operation of cylinder head bolts
- **Suitable for impact wrenches**
- □ drive 20 = 3/4"
- Reinforced design
- Chrome-Vanadium special steel
- Surface burnished

HAZET No.	l mm	mm	EAN-No. 4000896+
-----------	------	----	------------------

On MAN commercial vehicles M 2000 and MAN busses with D 08 engines

2850-E 18	110	16,70	086412
-----------	-----	-------	--------

On MAN commercial vehicles F 2000, F 90, F 8 and MAN busses with D 25 and D 28 engines

2850-E 20	110	18,45	079681
-----------	-----	-------	--------

6-Point Socket



- For **tensioning the V-belt on the generator** on MAN F 90, F 2000 as well as MERCEDES-BENZ up to SK-series
- □ drive 12.5 = 1/2"

HAZET No.	S mm	l mm	EAN-No. 4000896+
2851-19	19	200	081165

Open Box-End Wrench



- For the screw connections at the hydraulic mains of the tilting devices for cabs on MAN trucks
- Wrench profile is especially matched for the screw connections
- s 14 with special profile
- Chrome-Vanadium
- Surface chrome-plated

HAZET No.	S mm	l mm	EAN-No. 4000896+
2852-1	14	130,4	100064

Cylinder Head Wrench



- For the operation of **cylinder head bolts without removing the injection nozzles and pipes** – e.g. during maintenance work – on MAN commercial vehicles type F2000, F90, F8 and MAN busses with D25 and D28 engines
- For outside TORX® screws E 20
- □ drive 12.5 = 1/2"

HAZET No.	l mm	mm	EAN-No. 4000896+
2858-E 20	164	18,45	085675

Impact Socket



- For the operation of the bumper screws on commercial vehicles MAN with metal bumpers
- 12-point
- **Suitable for impact wrenches**
- Chrome-Vanadium special steel

The ornamental 12-point screw is sunk into the bumper. The Impact Socket is especially suitable for the small area with difficult access between screw profile and bumper.

HAZET No.	S mm	l mm	EAN-No. 4000896+
2860 Z-24	24	45	089239

Open-End Insert Tool



- For the operation of the oil pressure switch on MERCEDES-BENZ commercial vehicles with 541-542 engines as well as on MAN commercial vehicles of the series F and M
- Tool profile is especially matched for the existing spaces
- **Extra-slim style (8 mm)** allows access between motor unit and switch and appropriate operation of the switch
- Chrome-Vanadium
- Surface chrome-plated

HAZET No.	S mm	l mm	EAN-No. 4000896+
2870-24	24	52	103638

Did you know that...

Top

- ...HAZET is the leading manufacturer of specialty tools for the automotive industry in Germany?
- 5000** ...the product range comprises about 5000 quality tools for professional application?
- 95** ...HAZET exports tools into 95 countries?

Tool Assortment

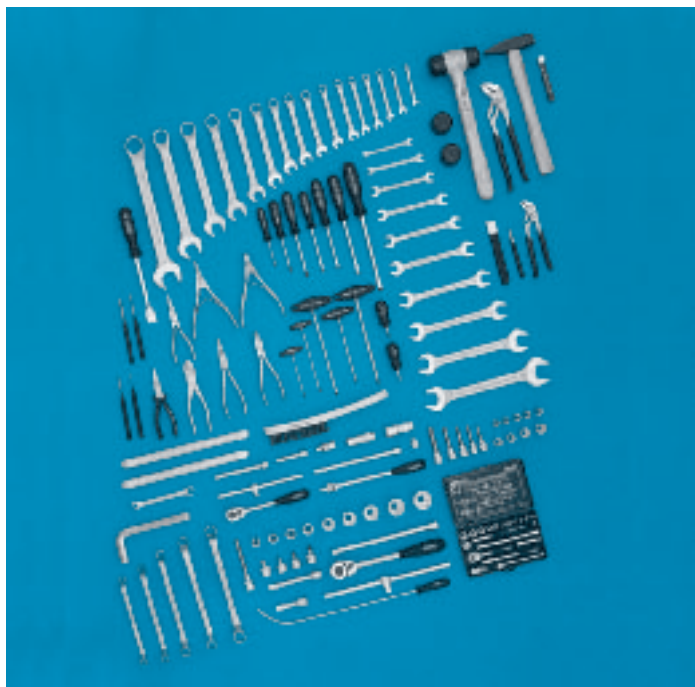

BMW Classification to vehicles: pages 171-190



assortment with 134 parts for BMW motorcycles

contents:
 450N-6x 7 8x 9 10x11 12x13
 14x15 16x17 18x19 20x22
 24x26 27x32
 603-6 7 8 9 10 11 12 13
 14 15 17 19 22 24 27 32
 612-10x11
 630-10x11 12x13 14x15
 16x17 18x19
 650-12
 730-4 746-1
 748b-2 3 4 5
 760N-1 2
 801 K-55 801 K-PH1
 803-40 55 65 100
 803-PH0 PH1 PH2
 824
 828-2,5 3 4 5 6
 850-4 4,5 5 5,5 6 7 8 9 10 11 12 13 14
 863P 864 865
 866U 867-2 868 869
 880Z-9 10 11 12 13 14 15 17 19
 880AMg T-3 880MgT
 8801-5 6 7 8 10
 8814 8815
 8816P 8820
 8821-3 5 8
 8858-2
 900-14 15 17 19 22 24 27 30 32
 915 916SP
 917-3 5 918-10 958-2
 985-6 8 10
 986SLg-8
 1802-2 1816-22 1841 a-2
 1846 a-2 1846 b-2
 1846 c-2 1846 d-2
 1952-050 50 1976-2
 2100-17 2130
 2140-5 2147

Tool Assortment

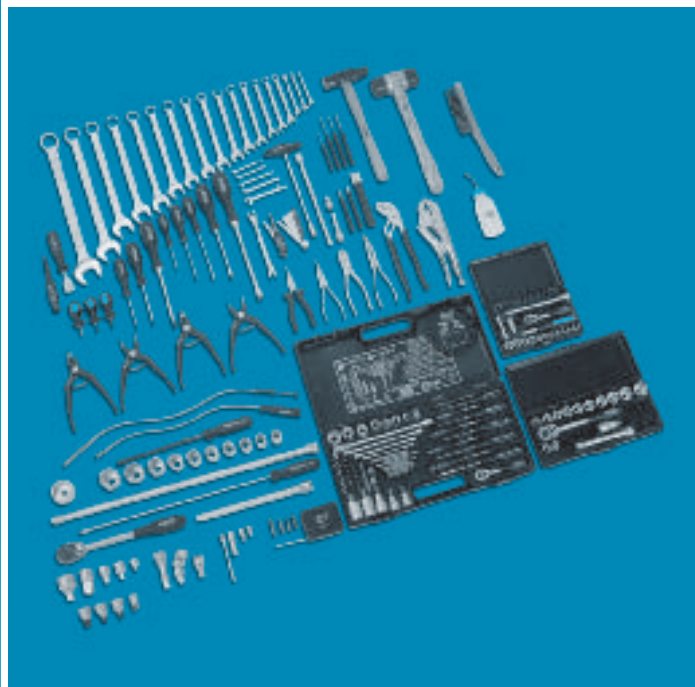

assortment with 204 parts for BMW passenger cars



contents:
 426-6 428-10
 440-5,5 6 7 8 10
 600N-6 7 8 10 11 12 13 14 15
 16 17 18 19 21 22 24 27 32
 612N-10x11
 730-4 741-1 746-1
 748 a-2 748 b-3 4 5
 755-10 760N-2
 801 K-55
 801 K-PH1 PH2
 803-20 40 55 80 100
 803-PH1 PH2 PH3
 803Lg-55
 803-T 6 T 7 T 8 T 9 T10
 T15 T20 T25 T27 T30
 823 824-1
 850-4 5 5,5 6 7 8 9 10 11 12 13 14
 850Lg-10
 850-E4 E5 E6 E7 E8
 858-1 871-1 4 863P 866U
 867-2 868 869
 8501-3 4 5 6 8
 8503-0,6x3,5 1x5,5 1,2x8
 8506-PH1 PH2 PH3
 880-10 11 12 13 14 15 16 17 18 19 21 22
 880-E10 E11 E12 E14
 8802-T40 T45
 8816P 8820 8821-3 5 10 8822-1
 8858-1 2
 900-16 17 18 19 21 22 24 27
 900Z-30 32
 900-E16 E18 E20 E24
 916SP 917-3 918-10 23
 919-1 920
 958-1 -2
 985-10 12 14
 992-T50 T55 T60
 1058-2
 1802-2 1816-22
 1841 a-2 1841 b-3
 1845 a-19 1845 b-19
 1845 c-19 1845 d-19
 1952-50 1975 1976-2
 2115-T 6 T 7 T 8 T 9 T10 T15
 T20 T25 T27 T30 T40
 2130 2140-5 2147 2152/3
 2154-5 2161 2169-36
 2206-5 6 8
 2217-PH4
 2223-T6
 2223-T 7H T 8H T 9H T10H T15H
 T20H T25H T27H T30H T40H
 2223Lg-T25
 2250-1 2 3 2264

Plastic Inserts

HAZET plastic drawer insert suitable for BMW assortment 0-2900/204 for Tool Trolley *Assistant*

contents:

161-24 PL 28 PL 48 PL

161-880 PL 161 PL

2900-1 PL 2 PL 3 PL 4 PL 5 PL 7 PL 8 PL 9 PL

HAZET No.	EAN-No. 4000896+
2900/13 PL	080632

Socket with Hinge Joint



- For inside hexagon screws on **rear calipers** on BMW 3-, 5- and 8-series
- drive 10 = 3/8"

HAZET No.	S mm	l mm	EAN-No. 4000896+
2901 G-7	7	48,5	051816

Sockets



- For outside TORX® screws E12 at the **cylinder head**, engine M 42, 1.8 l, 4-cyl. with 4 valve technique, 318 is since 1989, engine M 50, 2.0 l, 2.5 l 6-cyl. with 4 valve technique of 5-series since 1991, 520i, 525i
- Long style
- With ball clamping (annular spring and ball)
- drive 12.5 = 1/2"

HAZET No.	S mm	l mm	EAN-No. 4000896+
2925	11,17	140	018284



- For the shock absorber piston rod on the stabilizing bearing/spring leg on BMW 3-, 5- and 7-series since 1988
- In conjunction with e.g. HAZET Torque Wrench 6291-1 CT and HAZET Double Box Insert Tool 6630 d-22 – please consider BMW installation instructions – stabilize piston rod with HAZET No. 868 and 8501-6 resp. 850-10
- 22 mm outside hexagon drive
- Chrome-Vanadium
- Surface chrome-plated

HAZET No.	S mm	l mm	EAN-No. 4000896+
2927	22	140	051595

Flexible Hex Head Wrench



- For the oil drain plug and oil level plug with inside hexagon at the rear axle differential 10 mm up to 1991 14 mm since 1991
- Flexible heads
- Chrome-Vanadium
- Surface chrome-plated, blades burnished

HAZET No.	S mm	l mm	EAN-No. 4000896+
2944-10 x 14	10x14	270	018338

Seal Pusher



- For pressing on **valve stem seals** ø 7 and 8 mm on BMW passenger cars
- Special steel
- Surface burnished

HAZET No.	EAN-No. 4000896+
2977	053704

Valve Retainer Ring Pliers



- For **removing valve stem seals** especially on BMW multi-valve engines since 1990, OPEL-Omega B, 2.5 l Turbo-diesel, FORD-Fiesta since 1996
- Jaws hardened, longitudinally toothed
- Working area dip-insulated avoiding damages of the timing gear

HAZET No.	l mm	EAN-No. 4000896+
2991	250	018352



Asia

HAZET –
Official Supplier of
PORSCHE
motor sport



Tool Assortment



OPEL

Classification to vehicles: pages 171-190



assortment with 141 parts
for OPEL passenger cars

contents:

600N-6 7 8 9 10 11 12 13
14 15 16 17 18 19 21 22

612-10x11

630-6x 7 8x10 12x13 14x15
16x17 18x19 22x24 27x32

730HS 730-1 6 746-2

748b-2 3

748Lgb-4 6

757-10

760N-2 796

801K-35

801K-PH1 PH2

803-55 65 10

803-PH1 PH2 PH3

803VDE-30 35 824

850-5,5 6 7 8 9 10 11

850-E8

863P 866U 867-2

868 869 870

880-12 13 14 15

880-E10 E12 E14

880AMg T-1

880G-13 15 17 19

880TZ-10 13 15 20,8 (1³/₁₆)

8816P 8820

8821-3 6 10 20

900-15 16 17 18 19 22 24 27 30 32

915 916SP

917-3 5

918-10 958-2

986-7 8 10 986SLg-8

990Lg-8 10 12

990-6 8 10

992-T55

1802-2 1850-2 1981

2100-015 02 025

2140-2 5 2143 2147

2152/3

2204-3 4 5 6

2223-T10 T15 T20 T25 T27 T30

2224-T40 T45 T50

2250-1 3

2262

4968-2



HAZET
No.

FAN-No.
4000896+

0-3000/141

000449

Socket

H.I.T.S. 12,5 1/2"



- For operation of the **deeply located screws of the safety belt casing** (B-pillar) on OPEL Astra G
- Extra long style
- □ drive 12.5 = 1/2"

HAZET No.	S mm	l mm	FAN-No. 4000896+
3012-13	13	120	062928

Screwdriver Sockets

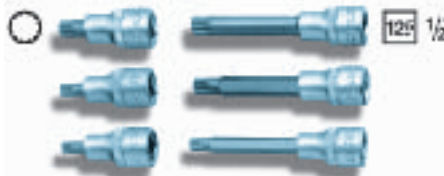

- For screws with internal serration (XZN), e.g. cylinder head bolts on OPEL, FORD, MERCEDES-BENZ, etc.
- □ drive 12.5 = 1/2"
- 6 parts

contents:

990Lg-8 10 12

990-6 8 10

HAZET No.	FAN-No. 4000896+
3090/6	018499

TORX® Screwdriver Sockets



□ drive 12.5 = 1/2"

HAZET No.	S mm	l mm	FAN-No. 4000896+
3092-T 50 H	8,83	55	018505
3092-T 55	11,22	55	050109

- For the fixing device of the spare wheel on bumper OPEL Frontera Sport
- For tamper resistant TORX® screws (inside TORX® screws with pin)
- For the operation of for cylinder head screws on OPEL Omega V 6
- For inside TORX® screws

Tool Assortment

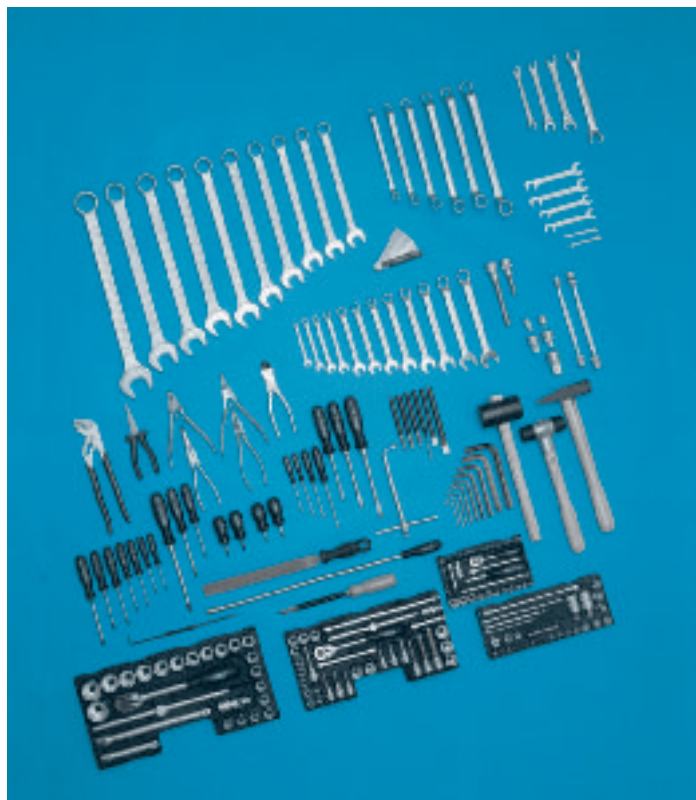

PORSCHE

Classification to vehicles: pages 171-190



assortment with 218 parts
for PORSCHE passenger cars



contents:

- 440-5,5 6 11 12 13 14
- 600N-20 21 22 24 25
27 29 30 32 36
- 603-6 8 9 10 12 13
14 15 16 17 18 19
- 609-E6xE8 E10xE12 E14xE18 E20xE24
- 612- 8x10 11x13 12x14 17x19
- 630-10x11 12x13 14x15 16x18 17x19 20x22
- 645-10x11 12x13
- 731-2 5 745a-6
- 745-4 746-2 748b-4 760N-2
- 801K-35 55 801K-PH1 PH2
- 803-20 25 30 35 55 65 80
- 803-PH1 PH2 PH3 821-1
- 803-T8 T9 T10 T15 T20 T25 T30
- 850-4 5 6 7 8 9 10 11 12 13 14
- 850-E5 E6 E7 E8
- 880-E10 E12 E14
- 8501-3 4 5 6 8
- 8503-0,6x3,5 0,8x4 1x5,5 1,2x8
- 8506-PH1 PH2 PH3 PH4
- 8507-PZ1 PZ2 PZ3
- 858-1 863P 865 866U 867-2 868 869
- 880-6 7 8 9 10 11 12 13
14 15 16 17 18 19 21 22
- 8801-4 5 6 8
- 8803-1x5,5 1,2x8 1,6x10
- 8806-PH1 PH2 PH3
- 8815 8816P 8820 8821-3 5 10 8858-1 2
- 900Z-10 11 12 13 14 15 16 17 18 19
20 21 22 23 24 26 27 28 30 32
- 900-E10 E12 E14
- 915 916SP 917-5 918-10 920 958-1 2
- 986Lg-8 10 992-T55 T60
- 1802-2 1816-22 1841b-3 1846a-2
- 1846c-2 1846d-2 1952-35 1976
- 2100-025 03 04 05 06 08 10 12 14
- 2122-10
- 2140-5 2143 2147 2150
- 2223-T10 T20 T25 T27 T30
- 2223-T30 H 2223Lg-T25
- 2224-T40 T45 T50
- 2250-1 3 5
- 2255-1

HAZET
No.

EAN-No.
4000896+

0-3300/218

057429

Tool Assortment



FORD

Classification to vehicles: pages 171-190



assortment with 78 parts
for FORD passenger cars



contents:

- 425-10
- 600N-6 7 8 9 10 11 12 13
14 15 16 17 18 19 22 24
- 612-11x13 12x14 16x18
- 630-10x11 13x15 16x17 19x22
- 730-4 746-2
- 748b-4 760N-2 797
- 801K-55 803-25 40 55 80
- 803-PH1 PH2 PH3
PZ1 PZ2 PZ3
- 880KF 8816G
- 900-8 10 11 13 14 15 16
17 18 19 21 22 24
- 915 916SP
- 917-3 5
- 918-10 920
- 986Lg-8 986-6
- 991-6 8
- 1802-2
- 1846a-2 1846b-2
- 1846c-2 1846d-2
- 1952-35
- 2100-04 08
- 2111-06 08
- 2130 2140-5 2147

HAZET
No.

EAN-No.
4000896+

0-3400/80

000463

Compressed Air Adapter



- For keeping installed valves lifted when installing and removing the cylinder head valve keys
- On FORD engines except CVH engines and multi-valve engines
- Spark plug threads M 14 x 1.25 and M 18 x 1.5
- Compressed-air supply 13 mm 6-point

HAZET No.	l mm	EAN-No. 4000896+
3428	140	018819

Cylinder Head Wrench



- For cylinder head bolts on FORD 1.9 2.1 2.3 2.5 l diesel, Granada, Sierra, and PEUGEOT 504, 505 Diesel, CITROËN Diesel, ISUZU
- □ drive 12.5 = 1/2"
- Chrome-Vanadium
- Surface chrome-plated

HAZET No.	S mm	l mm	EAN-No. 4000896+
3432	17	109	018840

Depressor



- For depressing the bucket tappets on 1.6 l, 1.8 l FORD diesel engine, Fiesta, Escort, Orion, 1.8 l Sierra Turbo diesel
- Working area surface-hardened
- Chrome-Vanadium
- Surface burnished

HAZET No.	l mm	EAN-No. 4000896+
3474	240	018857

Valve Shim Pliers



- For valve shim replacement
- For 1.6 l, 1.8 l diesel Fiesta, Escort, Orion, 1.6, 1.8 l diesel since 1989, 1.8 l Sierra Turbo diesel
- Tips hardened and tempered

HAZET No.	l mm	EAN-No. 4000896+
3499	260	018888

Tool Assortment

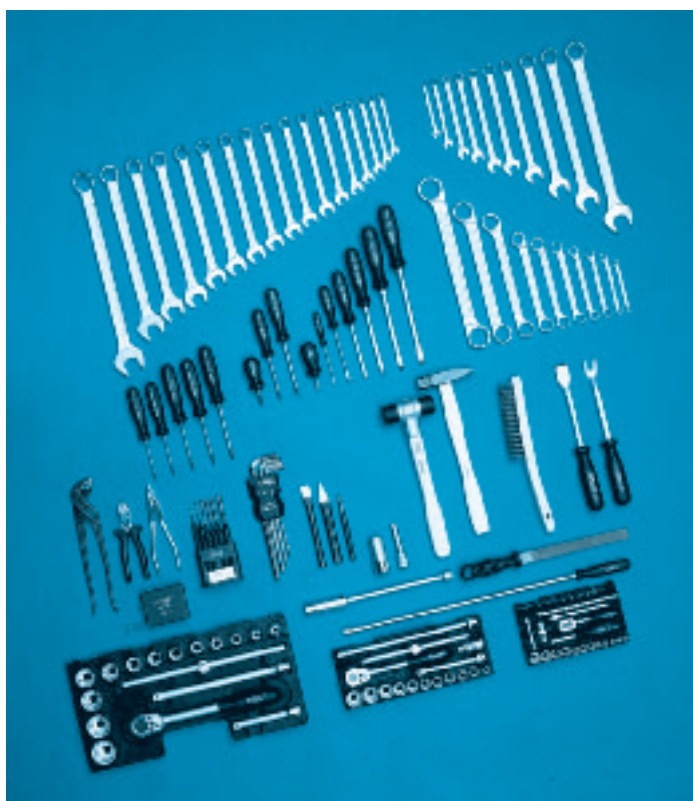

CHRYSLER

Classification to vehicles: pages 171-190



assortment with 148 parts for CHRYSLER



contents:

600 N-7 8 9 10 11 12 13 14 15
16 17 18 19 21 22 24 27
600 NA-1/4 5/16 3/8 7/16 1/2 9/16 5/8 3/4 7/8 1
610 N-6x 7 8x 9 10x11 12x13 14x15
16x17 18x19 21x22 24x27 30x32
731-5 740-3 746-1
751/6-1 759 N-2 799-3
801 K-55 801 K-PH2
801-T10H T15H T20H T25H T30H
803-25 30 35 40 65 80
803-PH1 PH2
824
850-4 5 5,5 6 7 8 9 10 11 12 13 14
8501-3 4 5 6 8
8503-0,6x3,5 1x5,5 1,2x8
8506-PH1 PH2
8507-PZ1 PZ2
863 P 865 866 U
867-2 868 869
880-8 10 11 12 13 14
15 17 19 21 22
880 KF 8801 A-3/8
8815 8816 P 8820
8821-5 10
900-10 11 12 13 14 15 17
19 22 24 27 30 32
915 916 SP
917-5 918-10
1802-11 1850-2
1952-35 1976
2105 Lg-015 02 025 03 04 05 06 08 10
2122-8 2130
2140-3 2147 MS 2154-5
4766-1

HAZET No.	EAN-No. 4000896+
0-3550/148	058051

Tool Assortment



supplementary assortment with 44 parts for CHRYSLER



contents:

- 850- E 4 E 5 E 6
- 8502- T 8 T10 T15
- 880- E 8 E10 E12
- 8802- T20 T25 T30
- 900AZ- 3/8 7/16 1/2 9/16 19/32
- 5/8 1 1/16 3/4 25/32 13/16
- 7/8 15/16 31/32 1 1 1/16
- 1 1/8 1 3/16 1 1/4
- 900-E 14 E 18 E 20
- 992-T40 T 50 T 55 T 60
- 915 916SP
- 917-5
- 918-10 920
- 6110-1CT 6122-1CT

HAZET No.

EAN-No. 4000896+

0-3550/44

058068

12-Point Socket



- For cylinder head bolts on CHRYSLER engines: Jeep Wrangler, Jeep Cherokee, Jeep Grand Cherokee, engines 2.5 and 4.0 l
- Suitable for impact wrenches
- Deep relief
- 12-point s 1/2
- □ drive 12.5 = 1/2"
- Chrome-Vanadium special steel
- Surface burnished
- DIN 3129

HAZET No.

d₁ mm

d₂ mm

l mm

EAN-No. 4000896+

3551-1

20,5

25

85

060412

HAZET – Tool Supplier of the Automotive Industrie



FORD – CHRYSLER

Tool Assortment

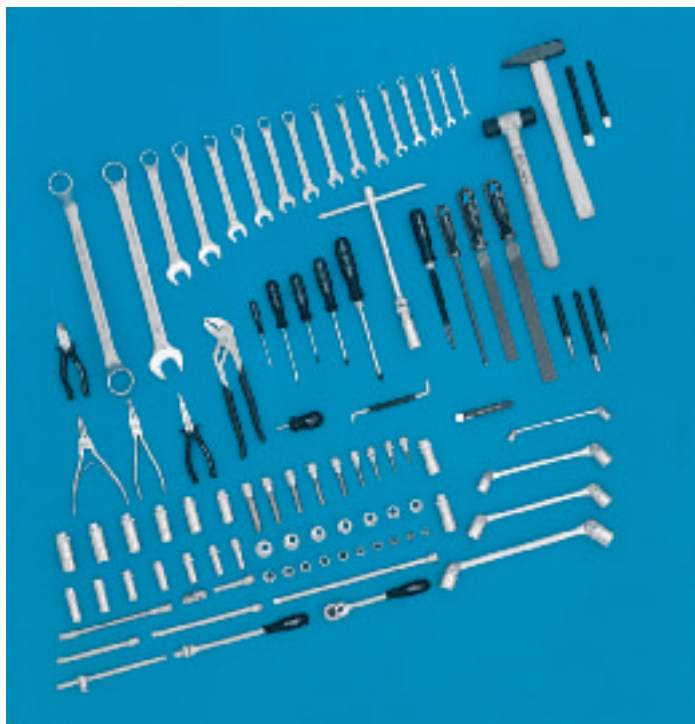

FIAT

Classification to vehicles: pages 171-190



assortment with 95 parts
for FIAT passenger cars

contents:

600 N-30
603-6 7 8 9 10 11 12
13 14 15 16 17 19 22
630-32x36
645-10x11 12x13 17x19 21x22
731-2 5 745 a-3 10
746-2 760 N-2
801 K-55 803-20 40
803-PH1 PH2 PH3
818-3 821-1
880-6 7 8 9 10 11 12 13 14
15 16 17 18 19 20 21 22
880 Lg-9 10 11 12 13 14 15
16 17 18 19 20 21 22
880 KF
8801-3 4 5 6 7 8 9 10 12
8814 8815
8816 P 8820
8821-3 6 8 12
8830
1803-11 1816-22
1846 a-2 1846 c-2 1952-35
2120-8 2122-8 10
2140-5 2147
4762

HAZET No.	EAN-No. 4000896+
0-3600/95	000470



Tool Assortment

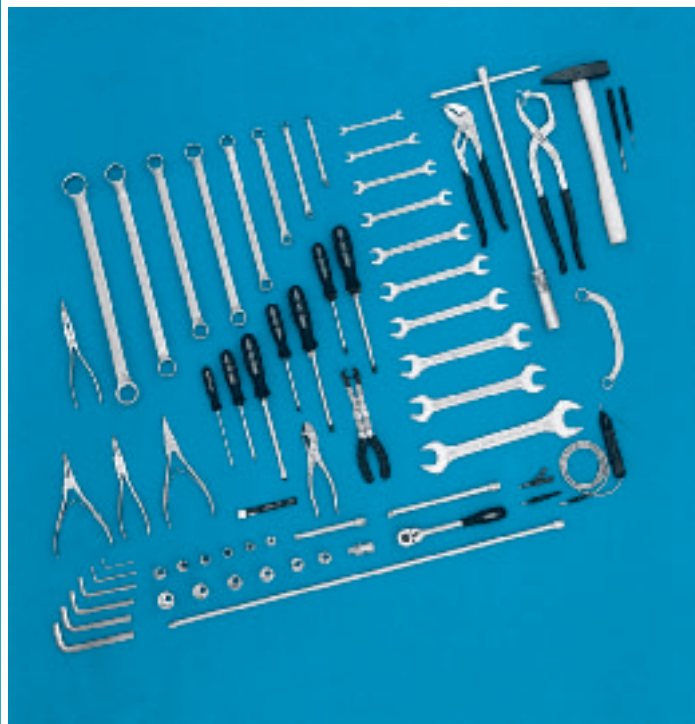

PEUGEOT

Classification to vehicles: pages 171-190



assortment with 65 parts
for PEUGEOT passenger cars

contents:

450 N-6x 7 8x 9 10x11 12x13 14x15
16x18 17x19 21x23 22x24 27x32
615-14x17
630-6x 7 10x11 13x15 17x19
20x22 21x23 24x27 27x32
748 a-2 748 b-5 760 N-2 797 799
803-35 40 65
803-PH2 PH3 PZ2 PZ3
880-8 10 11 13 14 15 16 17 18 19 21 22
8816 P 8820 8821-5 8 28 1802-2 1841 b-3
1846 a-2 1846 c-2 1847-2
2100-02 04 06 08 10 12
2140-5 2147 2152/3 4767 KF

HAZET No.	EAN-No. 4000896+
0-3700/65	000487



Oil Service Wrench



- For the oil filler and oil drain plug gearbox, differential, oil pan e.g. on FIAT, LANCIA, ALFA ROMEO, LADA
- For 12 mm inside hexagon screws
- Chrome-Vanadium
- Surface nickel-plated

HAZET No.	S mm	l mm	EAN-No. 4000896+
3601-12	12	230	018895

Oil Service Wrench



- For the oil filler and oil drain plug on gearbox, differential, oil pan on PEUGEOT and RENAULT vehicles since 1983
- Chrome-Vanadium
- Surface chrome-plated

HAZET No.	S mm	l mm	EAN-No. 4000896+
3701	8 x 10	238	018901

Oil Service Screwdriver Sockets



- For the oil filler and oil drain plug gearbox, differential, oil pan
- □ drive 12.5 = 1/2"
- Chrome-Vanadium
- Surface chrome-plated

Oil Service Screwdriver Sockets

HAZET No.	S mm	l mm	EAN-No. 4000896+
8 mm outside square for PEUGEOT, VOLVO 264, RENAULT since 1983, NISSAN Micra 1,5 D since 1998			
3702	8	36	018918
10 mm outside square for FORD-Sierra, Granada diesel, VOLVO V6, PEUGEOT 106, 205, 305, 306, 309, differential MAZDA with rear drive			
3702-1	10	36	018925

Oil Service Wrench



- For the oil filler and oil drain plug gearbox, differential, oil pan on various French passenger cars
- 8 and 10 mm outside square
- Chrome-Vanadium
- Surface chrome-plated

HAZET No.	S mm	l mm	EAN-No. 4000896+
3703	8 x 10	233	018932

Tool Assortment



RENAULT

Classification to vehicles: pages 171-190

assortment with 75 parts
for RENAULT passenger cars

- contents:
- 600N-6 7 8 9 10 11 12 13 14 15 16 17 18 19 20 21 22 23 24 27 32
 - 610N-6x7 8x9 10x11 12x13 14x15 16x17 18x19
 - 731-5 746-1 760N-2 801K-55 803-35 40 55
 - 803-PH1 PH2 818-1 824
 - 880-8 9 10 11 12 13 14 15 16 17 18 19 21 22
 - 8815 8816P 8820 8821-5 10 8858-1
 - 900TZ-17 1802-2 1952-28
 - 2100-02 025 03 04 05 06 08
 - 2130 2140-5 2147 2152/3

HAZET No.	EAN-No. 4000896+
0-3800/75	000494

TORX® Screw Driving Sets



- For inside TORX® screws
- Esp. for RENAULT commercial vehicles
- In sheet metal box
- With plastic insert
- 15 parts

contents:
8815 8858-2
2223-T 6 T 7 T 8 T 9 T10 T15
T20 T25 T27 T30 T40
2250-1 2255

HAZET No.	EAN-No. 4000896+
1557/15	003761

Tool Assortment



TOYOTA

Classification to vehicles: pages 171-190

assortment with 99 parts
for TOYOTA passenger cars

- contents:
- 425-7 8 10 12 14
 - 603-8 9 10 12 14 16 17 18 19 21 22 24 27 30 32
 - 746-1 748a-2 3 748b-4 5
 - 801K-55 801K-PH2
 - 803-40 55 80 803-PH2 PH3 PH4
 - 803-T20 T30 823 824
 - 850-4 5 5,5 6 7 8 9 10 11 12 13 14
 - 8501-3 4 5 6 8 8503-0,6x3,5 1x5,5 1,2x8
 - 8506-PH1 PH2 8507-PZ1 PZ2
 - 863P 865 866U 867-2 868 869
 - 900-10 12 14 16 17 18 19 20 24 27 30 32
 - 900TZ-12 14 900AKF 900KF
 - 915 916SP 917-5 918-10 920
 - 1802-2 1841 a-2 1846b-2 1846c-2
 - 1846d-2 1847-2 1952-40 1976-1
 - 2140-5 2147 2161

HAZET No.	EAN-No. 4000896+
0-4320/98	000517

Tool Assortment

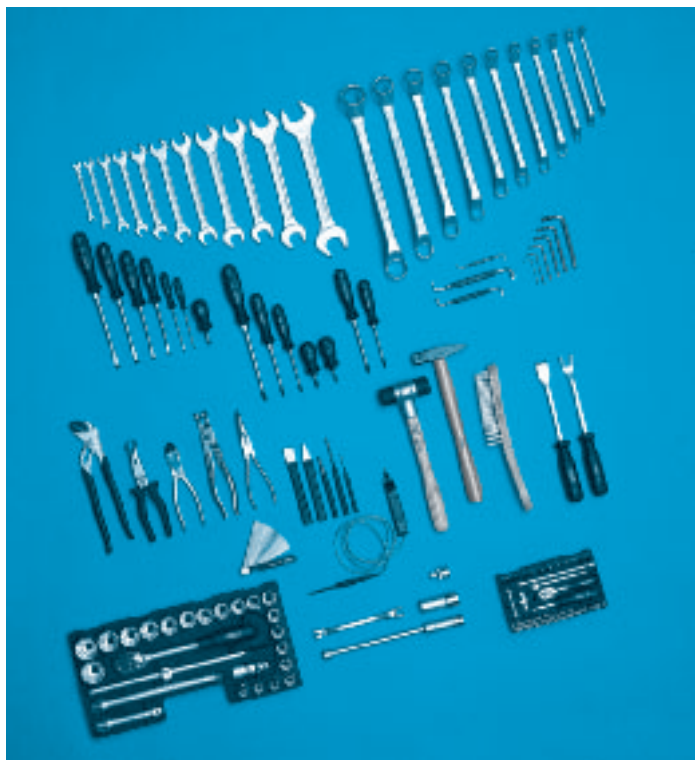

MAZDA

Classification to vehicles: pages 171-190



assortment with 121 parts
for MAZDA passenger cars



contents:

450 N-6 x 7 8 x 9 10 x 11 12 x 13 14 x 15
16 x 17 18 x 19 20 x 22 21 x 23 24 x 27 30 x 32
612 N-10 x 11
630-6 x 7 8 x 9 10 x 11 12 x 13 14 x 15 16 x 17
18 x 19 20 x 22 21 x 23 24 x 27 30 x 32
730-3 740-3 746-1 748 a-2 748 b-4
760 N-2 798-5 799-3
801 K-55
801 K-PH1 PH2
803-25 30 40 55 65 80
803-PH1 PH2 PH3 PZ1 PZ2
818-1 3 819-PH1+PH2 824
850-4 5 5,5 6 7 8 9 10 11 12 13 14
8501-3 4 5 6 8
8503-0,6x3,5 1x5,5 1,2x8
8506-PH1 PH2 8507-PZ1 PZ2
863 P 865 866 U 867-2 868 869
900-10 11 12 13 14 15 16 17 18 19
20 21 22 23 24 26 27 28 30 32
900 KF 915 916 SP 917-5
918-10 920 958-2
1802-2 1841 b-3 1849 1952-35
2100-02 03 04 05 06 08
2130 2140-5 2147 2152/3 4766-1

HAZET
No.

EAN-No.
4000896+

0-4350/141

058037

Spark Plug Wrench



10 3/8 E

- For 16 mm (5/8") spark plugs
- □ drive 10 = 3/8"
- With rubber ply
- Application:
VW 16 valve engines,
MAZDA 626, 2.0l, 16 valves with DOHC engine since 1987,
MAZDA 323, 1.6l and 1.9l since 1989, MX 5, 1.6l, since 1990
- Special steel
- Surface mat chrome-plated

HAZET
No.

mm
"

l
mm

EAN-No.
4000896+

2506

16 (5/8)

270

016297

Tool Assortment



NISSAN

Classification to vehicles: pages 171-190



assortment with 100 parts
for NISSAN passenger cars



contents:

428 Lg-10 12
600 N-8 10 12 13 14 15 16
17 18 19 21 22 24 27
746-1 748 a-2 748 b-4
760 N-2 799-3
801 K-55 801 K-PH2
803-40 55 65 80
803-PH1 PH2
824
850-4 5 5,5 6 7 8 9 10 11 12 13 14
8501-3 4 5 6 8
8503-0,6x3,5 1x5,5 1,2x8
8506-PH1 PH2 8507-PZ1 PZ2
863 P 865 866 U 867-2 868 869
880-6 7 8 9 10 11 12 13 14
15 16 17 18 19 20 21 22
880 KF
8815 8816 P 8820 8821-3 6
958-2
1802-2 1841 a-2
1846 b-2 1846 c-2 1846 d-2
1847-2 3 1952-40 1976-2
2140-5 2147 2152/3
4766-1

HAZET
No.

EAN-No.
4000896+

0-4370/100

058044

Socket



H.I.T.S.

- For the operation of the reverse gear switch on NISSAN cars
- Special profile s 19
- □ drive 10 = 3/8"
- Chrome-Vanadium
- Surface chrome-plated

HAZET
No.

S
mm

l
mm

EAN-No.
4000896+

4373-19

19

66

060351

Oil Service Wrench



- For oil drain plugs with square heads e.g. on NISSAN
- Flexible heads with locking device
- Inside double square heads
- Chrome-Vanadium
- Surface chrome-plated

HAZET No.	S mm	l mm	EAN-No. 4000896+
4374	14 x 17	260	020027

Tool Assortment



HONDA

Classification to vehicles: pages 171-190



assortment with 50 parts for HONDA passenger cars



- contents:
- 428 Lg-8 10 12
 - 603-8 10 12 14 16 17 18 19
 - 746-1 748 b-2 4 760 N-2
 - 801 K-55 801 K-PH2
 - 803-40 55 65
 - 803-PH1 PH2 PH3
 - 824
 - 900-8 10 12 14 16 17 18 19 21
 - 900 TZ-14 900 Z-10
 - 916 SP 917-3
 - 918-10 920 958-2
 - 1803-22 1841 a-2
 - 1847-2 1952-40
 - 2140-5 2147
 - 2152/3
 - 4766-1

HAZET No.	EAN-No. 4000896+
0-4390/50	000548

Tool Assortment



MITSUBISHI

Classification to vehicles: pages 171-190



assortment with 81 parts for MITSUBISHI passenger cars



- contents:
- 450 N-6 x 7 8 x 9 10 x 11 12 x 13 14 x 15 16 x 18 17 x 19 20 x 22 24 x 27 30 x 32
 - 630-6 x 7 8 x 9 10 x 11 12 x 13 14 x 15 16 x 18 17 x 19 20 x 22 21 x 23 24 x 27 30 x 32
 - 730-2 6 746-1 748 a-2 748 b-4 760 N-2
 - 801 K-55 801 K-PH2
 - 803-25 30 40 55 65 803-PH1 PH2 PH3
 - 880-6 7 8 9 10 11 12 13 14 16 17 18 19 21 22
 - 880 KF
 - 8815 8816 P 8820
 - 8821-3 5 20 8858-1
 - 986 Lg-6 8
 - 1802-2 1841 b-3
 - 1846 a-2 1846 b-2 1846 c-2 1846 d-2
 - 2100-02 025 03 04 05 06 08
 - 2130 2140-5 2147 2152/3

HAZET No.	EAN-No. 4000896+
0-4410/81	000555

FUEL SUPPLY



Fuel-Line Pliers



H.I.T.S.

- For the operation of **quick release fasteners at the fuel line and at the fuel tank aeration with slight pressure** on OPEL Corsa B, Astra F, G, Vectra B, Omega B, CHRYSLER Neon 1.8, Stratus 2.0 and 2.5, RENAULT passenger cars since 1997
- Solid plastic body
- Chrome-Vanadium tips

HAZET No.	l mm	EAN-No. 4000896+
4501-1	155	058624

Choke Angle Meter



- For choke adjustment of injection systems on VW-AUDI
- Angular scale range: 0-90°

HAZET No.	S mm	l ₂ mm	EAN-No. 4000896+
4502		020324	

Screwdrivers



- For 3 mm inside hexagon screws
- For mixture control at the fuel distributor of K-Jetronic injection systems on VW-AUDI, MERCEDES-BENZ, PORSCHE 924, FORD and BMW
- Extra long style, blade length 295 mm
- Chrome-Vanadium
- Surface chrome-plated, tips burnished

HAZET No.	S mm	l ₂ mm	EAN-No. 4000896+
4516	3	376	021222



- For idling setting screws, mixture control of Pierburg carburetors: BMW, FORD, OPEL, PEUGEOT, RENAULT, MERCEDES-BENZ passenger cars, butterfly valve setting on AUDI 80, VW-Passat 1.3-1.5 l
- Extra long style, blade length 296 mm
- For slotted screws
- Chrome-Vanadium
- Surface chrome-plated, tips burnished

HAZET No.	S mm	l ₁ mm	l ₂ mm	EAN-No. 4000896+
4517	0,6	4	360	021239

Screwdriver Bit



- For carburettor adjustment (CO) of all NISSAN cars, except cars with SU carburettor and injection systems
- With dovetail blade
- drive 6.3 = 1/4", in conjunction with Bit Holder HAZET 2255-1 or HAZET 4525-3
- Special steel

HAZET No.	l mm	EAN-No. 4000896+
4525-2	28	021642

Bit Holders for Screwdriver Bits



- For injection lines
- Chrome-Vanadium
- Surface chrome-plated

Bit Holders for Screwdriver Bits

- drive 6.3 = 1/4"
- Flexible shaft
- In conjunction with Screwdriver Bit HAZET 4525-2, for carburettor adjustment (CO) in engines of series "A" and "L" without air cleaner removal, on all NISSAN cars, except Stanza (T11), 280ZX, 280ZX-T (S130)

HAZET No.	l ₂ mm	EAN-No. 4000896+
2255-1	312	050079



- Extra-short style
- drive 6.3 = 1/4", in conjunction with Screwdriver Bit HAZET 4525-2 for carburettor adjustment (CO) on NISSAN cars

HAZET No.	l ₁ mm	l ₂ mm	EAN-No. 4000896+
4525-3	4	67,5	021659

Open Box Wrench



Line Wrench

- For injection lines of the HDi engines on CITROËN and PEUGEOT
- Torque control – even on screws in areas with restricted access – is possible with a common Torque Wrench drive 10 = 3/8"
- 12-point ≤ 14 mm
- drive 10 = 3/8"
- Chrome-Vanadium
- Surface chrome-plated

HAZET No.	S mm	EAN-No. 4000896+
4548-14	14	085668

Open 12-Point Sockets

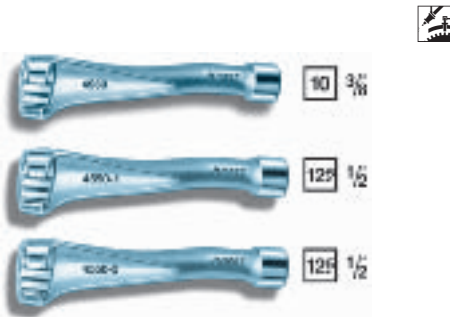

- For injection lines
- Chrome-Vanadium
- Surface chrome-plated

Open 12-Point Sockets

HAZET No.	S mm	l mm	EAN-No. 4000896+
-----------	------	------	------------------

- drive 10 = 3/8" for BMW diesel engines and OPEL 2.5 TD engines

4550	17	115	021680
------	----	-----	--------

- drive 12.5 = 1/2", on MERCEDES-BENZ 100, 130, 314, 360, 360h, 352A, 346/355, 401, 402, 403, 407h, 615, 616, 617

4550-1	17	120	021697
--------	----	-----	--------

- drive 12.5 = 1/2", on MERCEDES-BENZ M 352, A, 346/355, A, 401, 402/422, LA, 403, 407h, for the dip stick guide tube on M 314

4550-2	19	120	021734
--------	----	-----	--------

Open Box Wrench



- For injection line union nuts on 4-cyl. diesel engine MERCEDES-BENZ 601, 190D, C 200 D, E 200 D, Turbo-Diesel, 603, G 300 D, G 350 D, Turbo, Off Road cars, E 300 D, Turbo, S 350 Turbo-Diesel

- 14 mm 12-point
- drive 6.3 = 1/4"
- Chrome-Vanadium
- Surface chrome-plated

HAZET No.	S mm	l mm	EAN-No. 4000896+
4550-14	14	33	021703

6-Point Socket



- For injection nozzles on MERCEDES-BENZ diesel engines MB-types 202 (C-class) and 210 (E-class) with 604, 605 and 606 engines

- With window
- drive 12.5 = 1/2"
- Chrome-Vanadium
- Surface chrome-plated

HAZET No.	S mm	l mm	EAN-No. 4000896+
4550-22	22	110	021741

Open 12-Point Socket



- For the fastening nut on the injection nozzle MERCEDES-BENZ M 314, 352A, 360, 360h, 346/355, A

- drive 12.5 = 1/2"
- Chrome-Vanadium
- Surface chrome-plated

HAZET No.	S mm	l mm	EAN-No. 4000896+
4550-30	30	136	021765

12-Point Sockets



- For **injection nozzles** on diesel engines VW-AUDI, MERCEDES-BENZ, OPEL, FORD, PEUGEOT, VOLVO, TOYOTA, MAZDA, NISSAN, MITSUBISHI, DAIHATSU
- Special relief to accommodate leakage return tubes
- drive 12.5 = 1/2"
- Chrome-Vanadium
- Surface chrome-plated

HAZET No.	S mm	l mm	EAN-No. 4000896+
4555 N	27	85	021840



- For **injection nozzles** on BMW-Diesel M21 = E30 = 324TD
E28 = 524TD
E34 = 524TD
M51 = E36 = 325TD
E34 = 525TDS,
FORD-Diesel LINCOLN Continental (USA), LINCOLN Mark VII, VIILSC
- drive 12.5 = 1/2"
- Chrome-Vanadium
- Surface chrome-plated

HAZET No.	S mm	l mm	EAN-No. 4000896+
4555-1	27	85	021802



- For **injection nozzles** on VW-Polo 1.3 l diesel engine, NISSAN Terrano TD 25, 27 since 1988
- With inside bore hole \varnothing 22 mm
- drive 12.5 = 1/2"
- Chrome-Vanadium
- Surface chrome-plated

HAZET No.	S mm	l mm	EAN-No. 4000896+
4555-3	22	82	021833

Serrated Wrench Socket



- For installing and removing the **injection pump pipe socket** on the MRSF-ERE fuel injection pump, on MERCEDES-BENZ diesel passenger cars, 601, 602, 603, 605, 606, 615, 616, 617
- With 33 teeth
- drive 12.5 = 1/2"
- Chrome-Vanadium
- Surface chrome-plated

HAZET No.	S mm	l mm	EAN-No. 4000896+
4556	17,9 x 20	55,5	021864

Crown Wrenches



For the operation of the **pressure nut at the nozzle holder**

HAZET No.	l mm	EAN-No. 4000896+
-----------	------	------------------

- For commercial vehicles MAN and MERCEDES-BENZ M 401/421, M 402/422, LA, A, M 403/423, M 470h
- drive 12.5 = 1/2"
- Chrome-Vanadium
- Surface chrome-plated

4558	72	021888
------	----	--------

- For commercial vehicles with EDC engines on MERCEDES-BENZ and MAN
- With hole bored through for connecting cable
- 32 mm outside hexagon drive
- Special steel
- Surface burnished

4558-1	120	050529
--------	-----	--------

- For e.g. commercial vehicles MERCEDES-BENZ and MAN
- With retainer for fixation between pressure nut and nozzle holder – avoids slipping down –
- 32 mm outside hexagon
- Special steel
- Surface burnished

4558-2	69	057344
--------	----	--------

Double Ended Flare Nut Wrench



- For installing and removing the **injection pipes** on VW-AUDI diesel engines: 1.6 l 4-cyl., 2.0 l 5-cyl., 2.4 l 6-cyl.
- Chrome-Vanadium
- Surface chrome-plated

HAZET No.	S mm	l mm	EAN-No. 4000896+
4560	17 x 17	221	021918

Flare Nut Wrench



- For installing and removing **injection lines on diesel engines**, esp. for 1.7 DTi 16V OPEL engines, e.g. on ASTRA G and Corsa B and C
- Due to slim style, the wrench may also be used on diesel engines of other car manufacturers
- Chrome-Vanadium
- Surface chrome-plated

HAZET No.	EAN-No. 4000896+
4560-17	084548

Single Box-End Wrench



- For the **fastening screws at the injection pump**, when replacing the toothed belt or adjusting the injection start
- Application on 1.6 l 4-cyl. diesel engine AUDI 80, VW Golf, Jetta, Caddy, Passat, Santana, CITROËN
- Chrome-Vanadium
- Surface chrome-plated

HAZET No.	S mm	l mm	EAN-No. 4000896+
4561	13	165	021925

Leak-Off Pliers

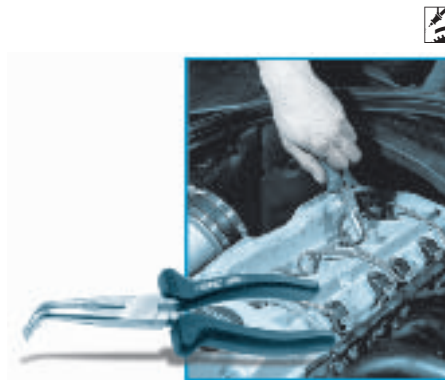

- For **installing and removing fuel return lines**
- Application e.g. on MERCEDES-BENZ diesel engines 601, 602, 603
- Ergonomic plastic handle covers with antislipping device
- Special steel
- Surface chrome-plated

HAZET No.	l mm	EAN-No. 4000896+
4565-1	186	059676

Flexible Hose Clamps



- For clamping flexible hoses
- Signalling colour yellow
- Made of plastic

HAZET No.	l mm	EAN-No. 4000896+
-----------	------	------------------

e.g. heating and fuel injection hoses up to 15 mm \varnothing

4590-1	150	021932
--------	-----	--------

for hoses up to 30 mm \varnothing

4590-2	180	021949
--------	-----	--------

e.g. radiator hoses up to 60 mm \varnothing

4590-3	253	055753
--------	-----	--------

Flexible Hose Clamps Set

- For clamping flexible hoses
- 2 parts: 4590-1 -2

HAZET No.	EAN-No. 4000896+
4590/2	021956

OIL SERVICE WRENCHES

Oil Service Tools Set



- For the oil filler and oil drain plug on gearbox, differential, oil pan and oil filter
- Application e.g. on VW-AUDI, MERCEDES-BENZ, BMW, FORD, OPEL, PORSCHE, PEUGEOT, RENAULT, FIAT, NISSAN, etc.
- 22 parts on perforated sheet metal display

contents:
 630-17 x 19
 2168 2169 2169-1 36
 2171-5 6 2172
 2567-1 16 2760 2760-2
 2944-10 x 14 3601-12
 3701 3702 3702-1 3703 3830
 4374 4618

HAZET No.	EAN-No. 4000896+
4616 T/21	059478

Display Board, empty

4616/21TL	059461
-----------	--------

Oil Service Wrench



- For the oil filler and oil drain plug on gearbox, differential, oil pan e.g. on FORD
- With different squares 8.7 9.5 10.5 11.5 13 6.8 15.2 16.5 19.7
- Special steel
- Surface chrome-plated

HAZET No.	l mm	EAN-No. 4000896+
4618	218	021994

MOTOR COMPONENTS / GENERATORS

Retainers



Retainers



- For retaining the pulley e.g. on generator
 - Special steel
- 4640-1: for V-ribbed belt pulley
 4640-2: for V-belt pulley

HAZET No.	l mm	EAN-No. 4000896+
4640-1	412	053728
4640-2	412	053735

Combinational Socket



- For installing and removing the V-ribbed belt pulley at the generator
- Application on VW, AUDI, SKODA, SEAT, PORSCHE, MERCEDES-BENZ, FORD, etc.
- Chrome-Vanadium blade special steel
- Set with 2 parts consisting of HAZET Adapter with internal serration 2592 and HAZET Screwdriver Socket 2751 (M 10)

HAZET No.	EAN-No. 4000896+
4641/2	081479

Combinational Socket Set

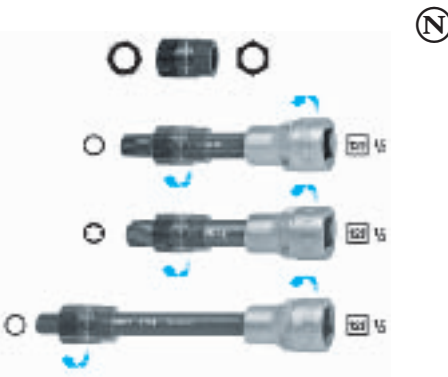

- For working on the built-in or dismantled generator
- For installing and removing the V-ribbed belt pulley at the generator
- Control of the screwing
- TORX® and XZN sockets for different inside profiles
- The generator is locked with the respective screwdriver socket and the screwing of the belt pulley is operated with the adapter with internal serration
- Application on VW, AUDI, SKODA, SEAT, PORSCHE, MERCEDES-BENZ, FORD, RENAULT etc.
- Set with 4 parts

contents:
 990 Lg-10
 992 Lg-T 50
 2592
 2751

HAZET No.	EAN-No. 4000896+
4641/4	103157

Combinational Socket Set



- For working on the built-in or dismantled generator
- For installing and removing the V-ribbed belt pulley at the generator
- Control of the screwing
- The generator is locked with the Screwdriver Socket 990 Lg-10 and the screwing of the belt pulley is operated with the 6-point Adapter 4642-1
- Application on RENAULT Mégane, Scénic, Kangoo
- Set with 2 parts

HAZET No.	EAN-No. 4000896+
4642/2	103430

6-point Adapter
 6-point drive ≤ 19 mm
 6-point output ≤ 28 mm

4642-1	103164
--------	--------

BATTERY SERVICE TOOLS

Battery Service Kit



- Made of acid-proof rubber, unbreakable
- Holds about 4 l of distilled water. The two openings accommodate the battery filler and acid tester, sealing the contents from contamination.
- 4 side compartments for tools
- With assortment of 8 parts

contents:
 450 N-10 x 11 12 x 13
 760 N-2
 803-40
 4650-0 1 2 4

HAZET No.	EAN-No. 4000896+
4650/8 N	022052

Box empty

4650 L	022069
--------	--------

Battery Filler



HAZET No.	l mm	EAN-No. 4000896+
4650-0	256	022007

Acid Tester



- For controlling the acid content of the battery fluid
- With aerometer

HAZET No.	l mm	EAN-No. 4000896+
4650-1	280	022014

Battery Terminal Lifter



- Total length 100 mm
- Chrome-Vanadium
- Surface chrome-plated

HAZET No.	sb mm	st mm	EAN-No. 4000896+
4650-2	60	40	022021

Special Tool for Battery Plugs



- For screwing the battery plugs in and out
- Profile is especially matched for the battery plugs
- Special length allows universal application in areas with restricted access
- Ergonomic T-handle made of plastic
- Chrome-Vanadium
- Surface chrome-plated

HAZET No.	mm	l mm	EAN-No. 4000896+
4650-3	14,5 x 1,7	95	102051

Battery Pole and Terminal Cleaner



HAZET No.	l mm	EAN-No. 4000896+
4650-4	120	022038

Battery Cell Tester



- **Fast diagnosis of the charging system and state of the batterie**
- Measuring range 6 and 12 volt for the application on passenger cars and motorcycles

HAZET No.	l mm	EAN-No. 4000896+
4650-5	333	022045

CAR ELECTRICITY / ELECTRONICS

Special Pliers



- For installing and removing **wedge base bulbs**, e.g. bulb in blower control switch on VW Passat since 1996, bulb in ambient air switch on OPEL Astra F, MERCEDES-BENZ and RENAULT passenger cars
- Blades made of special steel with plastic protective caps, pliers with solid plastic body

HAZET No.	EAN-No. 4000896+
4659-1	062379
Spare tips (pair) for Special Pliers 4659-1	
4659-01/2	103249

SYSTEM-Release-Tool Assortments



- For damage-free releasing of e.g. flat connectors
- Malfunctions due to connection defects can be repaired fast and easily
- Assortment with 12 parts in wooden box for universal application on the electricity (of passenger cars)

contents:
4661-1 2 4
4662-1 4 7 15 16
4663-2 4 6 4668-4

HAZET No.	EAN-No. 4000896+
4660-1/12	053223



- For damage-free releasing of connectors
- Assortment with 12 parts in wooden box for universal application on **commercial vehicles**

contents:
4661-1 4 5 7
4662-1 2 4
4663-4 6 4668-4

HAZET No.	EAN-No. 4000896+
4660-2/10	053216

SYSTEM-Release-Tool Assortments

(E)



- For damage-free releasing of connectors
- Assortment with 12 parts in wooden box for application on **VOLKSWAGEN-AUDI passenger cars**

contents:
 4661-1 3 4
 4662-1 4 6 7 8 15
 4663-1 4 6

HAZET No.	EAN-No. 4000896+
4660-25/12	053209

SYSTEM-Release-Tool Assortments

(E)



- For damage-free releasing of connectors
- Assortment with 10 parts in wooden box for application on **BMW passenger cars**

contents:
 4661-1 3 4
 4662-2 4 6
 4663-1 2 3 6

HAZET No.	EAN-No. 4000896+
4660-29/10	053186



(E)

- For damage-free releasing of connectors
- Assortment with 12 parts in wooden box for application on **MERCEDES-BENZ passenger cars**

contents:
 4661-1 3 4 8 9
 4662-1 9 16
 4663-2
 4668-1 2 3

HAZET No.	EAN-No. 4000896+
4660-27/12	053193



(E)

- For damage-free releasing of connectors
- Assortment with 12 parts in wooden box for application on **OPEL passenger cars**

contents:
 4661-1 2 4
 4662-1 2 10 11 12
 4663-1 4 6 9

HAZET No.	EAN-No. 4000896+
4660-30/12	053179



(E)

- For damage-free releasing of connectors
- Assortment with 18 parts in wooden box for application on **MERCEDES-BENZ passenger cars**

contents:
 4661-3 6 8 9
 4662-3 4 6 9 1/2 18/2 5/2
 4663-1 3 4/2
 4664-1 2 3 4666-2

HAZET No.	EAN-No. 4000896+
4660-27/18	062737



(E)

- For damage-free releasing of connectors
- Assortment with 10 parts in wooden box for application on **FORD passenger cars**

contents:
 4661-1 2
 4662-14 16 17
 4663-2 5 6 8
 4668-5

HAZET No.	EAN-No. 4000896+
4660-34/10	053162

SYSTEM-Release-Tools

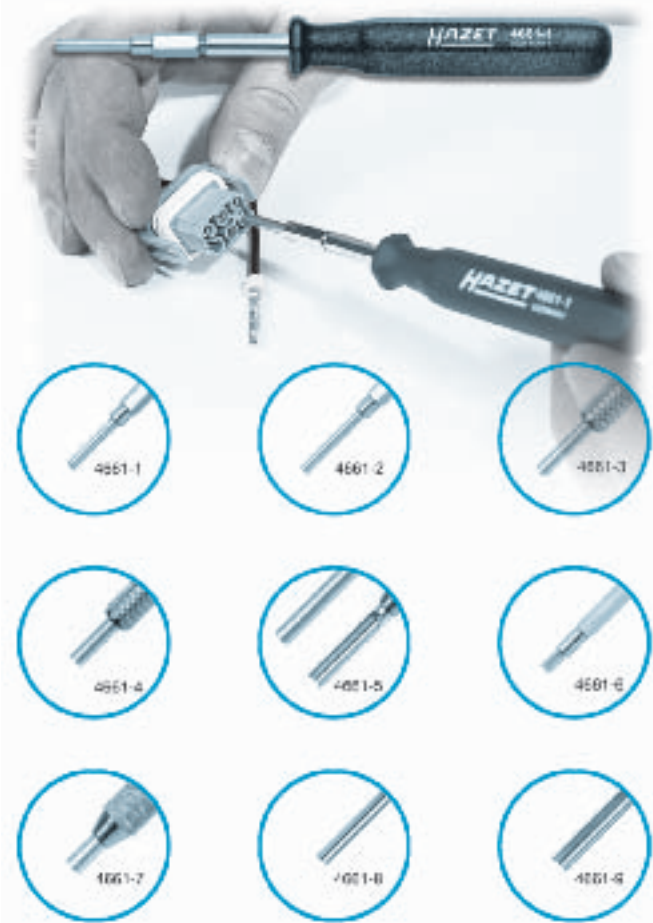

HAZET No.	EAN-No. 4000896+
for round pin connectors 1.6 mm	
4661-1	052288
Dismounting Socket	
4661-01	052370
for round pin connectors 2.3 mm	
4661-2	052295
Dismounting Socket	
4661-02	052387
for round pin connectors 2.5 mm	
4661-3	052301
Dismounting Socket	
4661-03	052394
for round pin connectors 3.5 mm	
4661-4	052318
Dismounting Socket	
4661-04	052400
for ABS round pin connectors 4 mm	
4661-5	052325
Dismounting Socket	
4661-051	052417
Mounting Socket	
4661-052	052448
for round pin connectors 1.5 mm in KOSTAL-housing	
4661-6	052332
Dismounting Socket	
4661-06	052424
for round receptacles 4 mm	
4661-7	052349
Dismounting Socket	
4661-07	052431
for soldering contacts 2.5 mm ϕ	
4661-8	052356
for soldering contacts 4 mm ϕ	
4661-9	052363

SYSTEM-Release-Tools



HAZET No.	EAN-No. 4000896+
for flat connectors 2.8/3.3 mm (Junior-Power-Timer and Standard-Power-Timer)	
4662-1	052455
for flat connectors 5.8/6.3 mm (Junior-Power-Timer and Standard-Power-Timer)	
4662-2	052462
for flat connectors E 95	
4662-3	052479
for flat connectors Micro Timer II and III	
4662-4	052486
for flat connectors 4 mm	
4662-5	052493

SYSTEM-Release-Tools

H.I.T.S.

HAZET No.	EAN-No. 4000896+
for flat connectors 7.9 mm (Maxi Power Timer)	
4662-6	052509
for flat connectors JPT/SPT in BOSCH housing	
4662-7	052516
for Micro flat connectors with 2 transversal located snap-in pins	
4662-8	052523
for JPT and DUCON flat connectors	
4662-9	052530
for DUCON-TWIN flat connectors 0.8-1.5 and 2.8 mm with 2 snap-in pins	
4662-10	052547
for DUCON flat connectors 4.8-6.3 mm	
4662-11	052554
for DUCON flat connectors 9.5 mm	
4662-12	052561
for flat connectors with asymmetrical snap-in pins 3.3 mm	
4662-13	052578
for flat connectors with asymmetrical snap-in pins 2.8 mm	
4662-14	052585
for flat connectors with asymmetrical snap-in pins 4.8 mm	
4662-15	052592
for flat connectors PIT-POD with one snap-in pin at the connector and one in the housing	
4662-16	052608
for flat connectors 6.8 mm	
4662-17	052615
for flat connectors 2.8 mm MERCEDES-BENZ commercial vehicles	
4662-18	057054
Release Blade 4662-01, Holder 4669-5	
4662-1/2	062607
Release Blade	
4662-01	062614
Release Blade 4662-05, Holder 4669-6	
4662-5/2	062652
Release Blade	
4662-05	062669
Release Blade 4662-018, Holder 4669-5	
4662-18/2	062621
Release Blade	
4662-018	062638

SYSTEM-Release-Tools



HAZET No.	EAN-No. 4000896+
for flat connectors, extraction channel 1.6 mm	
4663-1	052622
for flat connectors, extraction channel 1.9 mm	
4663-2	052639
for flat connectors, extraction channel 2.8 mm	
4663-3	052646
for flat connectors MICRO-TIMER I, MQS connectors	
4663-4	052653
for soldered receptacles	
4663-5	052660
for soldered connectors, also for JPT connectors with 1 snap-in pin	
4663-6	052677
for DUCON flat connectors (snap-in pin 0.8 and 1.5 mm)	
4663-7	052684
for flat connectors with one snap-in pin	
4663-8	052691
for flat connectors with one snap-in pin OKTAN plugs, MQS connectors	
4663-9	052707
for flat connectors MICRO standard, MQS connectors	
4663-10	052714
for flat connectors DUCON 2.8, 4.8 mm	
4663-11	052721
for flat connectors with one snap-in pin	
4663-12	052738
for flat connectors with snap-in pins in U-shape housing	
4663-13	052745
for flat connectors, with one snap-in pin at the connector and one in the housing	
4663-14	052752
for flat connectors without snap-in pins, but with locking notches in the housing	
4663-15	052769
with automatic ejector for MQS connectors MERCEDES-BENZ, BMW	
4663-16	059508
Release Blade 4663-04, Holder 4669-4	
4663-4/2	062683
Release Blade	
4663-04	062706

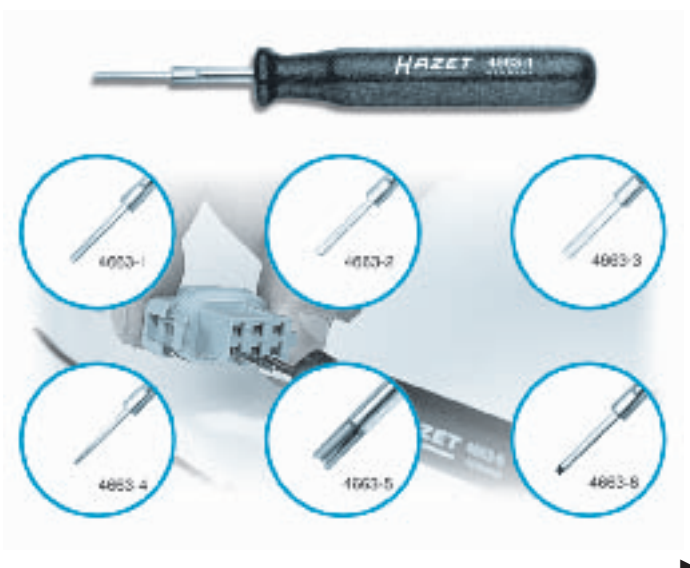

SYSTEM-Release-Tools



HAZET No.	EAN-No. 4000896+
for flat connectors SIDO with two snap-in pins	
4664-1	052776
for flat connectors SIDO with four snap-in pins	
4664-2	052783
for flat connectors SIDO with six snap-in pins	
4664-3	052790



2-way up to 9-way contact bridges
in multi-way Junior and Standard Power contact housings

HAZET No.	EAN-No. 4000896+
4665-1	052806
4665-2	052813
4665-3	052820
4665-4	052837
4665-5	052844



HAZET No.	EAN-No. 4000896+
for flat connectors with two snap-in pins and opening of the secondary locking device, OPEL Astra F fuse box	
4666-1	057580
MERCEDES-BENZ SLK 2.8 Design 97	
for flat connectors resp. receptacles with two snap-in pins and simultaneous opening of the secondary locking device	
4666-2	062713

SYSTEM-Release-Tools



HAZET No.	EAN-No. 4000896+
for secondary locking device MERCEDES-BENZ modular box 5.5 mm	
4668-1	052851
for secondary locking device MERCEDES-BENZ modular box 8.5 mm	
4668-2	052868
for secondary locking device MERCEDES-BENZ door housing	
4668-3	052875
for secondary locking devices on various housings	
4668-4	052882
Hook tool for removing the secondary locking device on FORD-housing	
4668-5	052899
Hook tool for removing the secondary locking device on FORD-housing	
4668-6	052905

HOLDERS for Release Tools



HAZET No.	for Blades	EAN-No. 4000896+
4669-4	4663-04	062690
4669-5	4663-02 and -018	062645
4669-6	4663-05	062676

EXHAUST SYSTEM

6-Point Sockets for Lambda Probes



- For lambda probe on NISSAN:
 - 100 NX 1.6 l B 13
 - 200 SX 1.8 l S 13
 - Micra 1.2 l K 10
 - 1.0 l K 11
 - 1.3 l K 11
 - Sunny 1.6 l B 12 N 13
 - 1.4 l N 14 Y 10
 - 1.6 l N 14 Y 10
 - Primera 1.6 l P 10 W 10
 - different FORD, VW, etc.

- Positive connection with the hexagon profile of the Lambda probe
- □ drive 12.5 = 1/2"
- Chrome-Vanadium
- Surface chrome-plated

HAZET No.	S mm	l mm	EAN-No. 4000896+
4680-1	22	92	022083

6-Point Sockets for Lambda Probes



- For lambda probe on MERCEDES-BENZ
- □ drive 12.5 = 1/2"
- Chrome-Vanadium
- Surface chrome-plated

HAZET No.	S mm	l mm	EAN-No. 4000896+
4680-2	22	110	022090



- For lambda probe on VW
- Outside hexagon drive 22 mm
- □ drive 12.5 = 1/2"
- Chrome-Vanadium
- Surface chrome-plated

HAZET No.	S mm	l mm	EAN-No. 4000896+
4680-3	22	110	022106

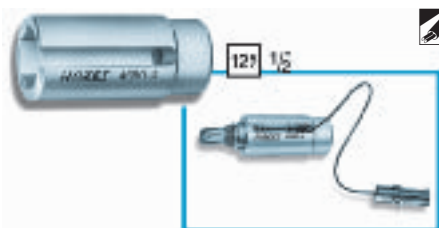

- For lambda probe with one connection cable only e.g. for OPEL, where the probe is screwed in the exhaust system behind the cooling system (multec fuel injection) e.g. Corsa A 1.2i 1.3i 1.4i, B 1.2i 1.4i, Kadett E 1.3i 1.4i 1.6i 1.8i, Astra 1.4i 1.6i 1.8i, Ascona C 1.6i, Vectra 1.6i 1.8i
- Extra-short style
- □ drive 12.5 = 1/2"
- Chrome-Vanadium
- Surface chrome-plated

HAZET No.	S mm	l mm	EAN-No. 4000896+
4680-4	22	70	022113

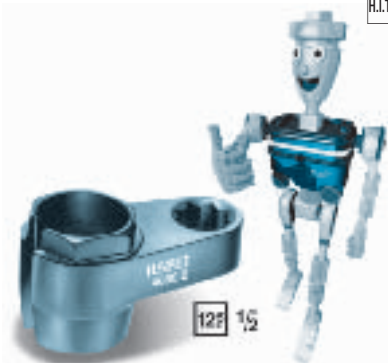

H.I.T.S.



- Universal application of the lambda probe e.g. on FORD, BMW, OPEL, VW-AUDI
- Double □ drive 12.5 = 1/2" or hexagon drive s 30 mm
- Chrome-Vanadium
- Surface burnished

HAZET No.	S mm	EAN-No. 4000896+
4680-5	22	057870

Open Box-End Wrenches



- For lambda probe e.g. on VW-AUDI, BMW engine M 70, 750i, 320, 325 M 20-engine, 316, 318 M 43-engine, FORD-Fiesta 1.1 and 1.6 l, Escort-Orion 1.4 l
- 10° offset
- With square connection 9 x 12 mm for e.g. HAZET 6396
- Chrome-Vanadium
- Surface chrome-plated

HAZET No.	S mm	l mm	EAN-No. 4000896+
4681-1	22	92,5	022120



- For lambda probe on VW-AUDI, FORD-Fiesta 1.3 l HCS, Escort 1.3 l, Mondeo 1.6 l 16 V, 1.8 l 16 V, 2.0 l 16 V, OPEL-Vectra, Kadett, Calibra 2.0 l 16 V, Omega B 2.5i and 3.0i, PORSCHE 911 Turbo
- 2 x 90° offset
- With square connection 9 x 12 mm
- Chrome-Vanadium
- Surface chrome-plated

HAZET No.	S mm	l mm	EAN-No. 4000896+
4681-2	22	125,5	022137



- For lambda probe e.g. on VW-AUDI, BMW 520-525 with M 20-engine after removing a screen, OPEL-Vectra, Calibra, Omega A with 2.0 l engine, FORD-Scorpio 2.0 l, PEUGEOT 106, 205, 306, 309, 405, PORSCHE 911 Turbo
- 45° offset
- With square connection 9 x 12 mm
- Chrome-Vanadium
- Surface chrome-plated

HAZET No.	S mm	l mm	EAN-No. 4000896+
4681-3	22	138	022144



- For lambda probe especially on BMW
- 20° offset
- With square connection 9 x 12 mm
- Chrome-Vanadium
- Surface chrome-plated

HAZET No.	S mm	l mm	EAN-No. 4000896+
4681-4	22	48	053681

Open Box Wrench Set



Set with 4 parts: 3 Open Box Wrenches with Handle for lambda probes

contents:
4681-1 2 3
6396

HAZET No.	EAN-No. 4000896+
4681/4	048229

Chain Pipe Cutter



- For cutting exhaust pipes esp. pipes made of V2A-steel up to 2.5 mm wall thickness and 80 mm ø
- Extended cutting diameter by using the Extension Chain HAZET 4682-01
- Low power required due to large T-screw that – fixed by grip technique – enables easy adjustment during cutting process
- Special steel
- Surface nickel-plated

HAZET No.	l mm	EAN-No. 4000896+
4682	255	022168

Spare chain

4682-01	270	022175
Repair kit for chain 4682-01		
4682-01/9		057214

Mounting Hooks



- For installing and removing rubber retainers of the exhaust equipment on e.g. FORD-Fiesta, Orion, Escort, BMW, etc.
- Hook 40 mm, 9° offset
- With plastic T-handle
- Special steel
- Surface chrome-plated

HAZET No.	l mm	EAN-No. 4000896+
4684-1	209	022199



- For installing and removing rubber retainers of the exhaust equipment on e.g. VW-AUDI, MERCEDES-BENZ (except 190, type 201) OPEL, Japanese cars, etc.
- Hook 17 mm, half-round, 20° offset
- With T-handle
- Special steel
- Surface chrome-plated

HAZET No.	l mm	EAN-No. 4000896+
4684-2	209	022205

MOTOR ELECTRIC SPARK PLUG / GLOW PLUG

6-Point Socket for Glow Plugs



10 3/8

- For **installing and removing 12 mm glow plugs** e.g. on MERCEDES-BENZ 201 and 202 with 4 valve technique, also on OPEL, BMW and FORD
- **With ball clamping** (annular spring and ball)
- With universal joint
- □ drive 10 = 3/8"
- Chrome-Vanadium
- Surface chrome-plated

HAZET No.	mm	l	EAN-No. 4000896+
4760-1	12 / -	152	022229

Glow Plug Socket Pliers



- For **installing and removing glow plug sockets**
- For the new generation of diesel engines e.g. MERCEDES-BENZ, VW-AUDI and BMW
- Long bent jaws for the application of deeply located glow plug sockets in areas with restricted access
- Special jaw profile is well-suited to glow plug sockets
- Groove prevents cable damage
- Non-slip plastic handles

HAZET No.	EAN-No. 4000896+
4760-5	089130

Double Box Wrench for Glow Plugs – Ratcheting



- For **installing and removing glow plugs** e.g. on diesel engines VW-AUDI, RENAULT
- For glow plugs between the motor unit and the diesel injection pump
- Heads with hexagon profile
- s 8 mm for operation of conductor rail screws with limit stop to guide the 8 mm nut
- s 12 mm for the operation of glow plugs
- Special steel
- Surface chrome-plated

HAZET No.	EAN-No. 4000896+
4760-8 x 12	072859

Spark Plug Wrenches



12.5 1/2

- For 20.8 mm (13/16") spark plugs
- With joint and spring
- Rubber appliance ensures firm hold of spark plug
- □ drive 12.5 = 1/2"
- Special steel
- Surface mat chrome-plated

HAZET No.	mm	l	EAN-No. 4000896+
4762	20,8 / 13/16	300	048977

Spark Plug Wrenches



12.5 1/2

- For 16 mm (5/8") spark plugs
- With joint
- Rubber appliance ensures firm hold of spark plug
- □ drive 12.5 = 1/2"
- Special steel
- Surface mat chrome-plated

HAZET No.	mm	l	EAN-No. 4000896+
4762-1	16 / 5/8	300	048984



10 3/8

- For 16 mm (5/8") spark plugs (C-plugs) e.g. on motorcycles KAWASAKI, YAMAHA, HONDA, SUZUKI, DUCATI, as well as MERCEDES-BENZ engines
- With ball joint
- With fixing clamp for a firm hold of the spark plug
- Short style
- □ drive 10 = 3/8"
- Chrome-Vanadium
- Surface mat chrome-plated

HAZET No.	mm	l	EAN-No. 4000896+
4766	16 / 5/8	97	049295



10 3/8

- For 16 mm (5/8") spark plugs e.g. on VW engine VR6, AUDI, RENAULT V6 and V8, FORD, OPEL, BMW, NISSAN, HONDA, ROVER 213 and 800, MAZDA 626 and 323F, MITSUBISHI GDI
- With ball joint
- With fixing clamp for a firm hold of the spark plug
- □ drive 10 = 3/8"
- Chrome-Vanadium
- Surface mat chrome-plated

HAZET No.	mm	l	EAN-No. 4000896+
4766-1	16 / 5/8	270	048991



10 3/8

- For the operation of **14 mm spark plugs**
- With fixing clamp for a firm hold of the spark plug
- Application on RENAULT Twingo, Clio, Kangoo with 1.2 l 16 V engine as well as CITROËN C5 with 2.0 l HPI engine

HAZET No.	mm	l	EAN-No. 4000896+
4766-2	14 / -	-	087655

Spark Plug Wrenches



12.5 1/2

- With spring in the joint
- With fixing clamp for a firm hold of the spark plug
- □ drive 12.5 = 1/2"
- Chrome-Vanadium
- Surface mat chrome-plated

HAZET No.	mm	l	EAN-No. 4000896+
4767	20,8 / 13/16	472	049011

For 20.8 mm (13/16") spark plugs e.g. on MERCEDES-BENZ

HAZET No.	mm	l	EAN-No. 4000896+
4767 KF	20,8 / 13/16	472	049011
4767 A KF	16 / 5/8	480	049028

- For 16 mm (5/8") spark plugs
- With three outside guide collar

Relay Pliers



H.I.T.S.

- For safe **installing and removing of relays**, even small ones, e.g. on OPEL, FORD, MAZDA, CHRYSLER, NISSAN, VW passenger cars, MERCEDES-BENZ, MAN, IVECO commercial vehicles
- Jaws made of special steel
- Pliers with solid plastic body
- DBGM – German registered utility model

HAZET No.	l	EAN-No. 4000896+
4770-1	140	062409



INFORMATION fixing clamp

- Stainless and insensitive to heat
- Largest possible clearance of insulator – therefore no damaging
- 6 spring elements – firm hold of the plugs
- Absorbing of transverse motion
- Smooth socket surface avoids abrasion

Relay Pliers



- For installing and removing relays e.g. on OPEL, RENAULT and NISSAN
- Jaws 60° bent made of special steel
- Pliers with solid plastic body

HAZET No.	l / mm	EAN-No. 4000896+
4770-2	197	074976

Socket Extension



- For installing and removing the electronic control unit through the windscreen (driver's side) on AUDI A4 until 2000, A6 until 2004 and VW Passat model years 1995–2002
- With magnetic insert
- Chrome-Vanadium
- Surface chrome-plated

HAZET No.	S / mm	l / mm	EAN-No. 4000896+
4775-8	8	120	104451

Cylinder Head Tightness Tester



Cylinder Head Tightness Tester

- For the detection of cylinder head gasket defects, leaks between the cooling system and the combustion chamber
- For water-cooled combustion engines (gas, diesel and gasoline)

HAZET No.	EAN-No. 4000896+
3 parts in sheet metal box contents: 4793-1 2 3	
4793/3	076192
Tester	
4793-1	076185
Reaction Fluid	
4793-2	076208
Flushing fluid	
4793-3	076215

Engine Leakage Tester



- For the diagnosis of engine defects e.g. on inlet and exhaust valves, pistons/piston rings and cylinder head/cylinder head gasket
- Easy application, immediate test result

HAZET No.	EAN-No. 4000896+
Tester with adapters	
4795-1	083770
Adapter for motorcycles thread M12 x 1.25 (external thread)	
4795-11	083787
Adapter for motorcycles thread M10 x 1 (external thread)	
4795-12	083794
Adapter for diesel engines thread M24 x 2 (external thread)	
4795-13	083800
Adapter for VW diesel engines 4795-11 included pin \varnothing 7 mm	
4795-14	083817
Adapter for multi-valve engines	
4795-15	104345

COOLING SYSTEM

Tester for Cooling Systems



- For cooling system testing
- Testing different types of cars is possible by building up pressure with Tester HAZET 4800-1

contents: 4800-1 2 3 4 5 6 7 8 9

HAZET No.	EAN-No. 4000896+
Assortment 9 parts, in plastic box	
4800/9	022359
Box, empty, with insert	
4800/9 KL	049820



SPARE PARTS:

HAZET No.	EAN-No. 4000896+
Cooling Pump with in-line quick coupling up to 2.5 bar	
4800-1	022243
Intermediary Hose, flexible	
4800-2	022274
Adapter for Radiator STANDARD, e.g. MERCEDES-BENZ-Vito, Viano, PORSCHE, FIAT, KIA, MITSUBISHI	
4800-3	022281
RENAULT, PEUGEOT, CITROËN, FIAT-Tipo, Tempra (also suitable as adapter for the cooling systems as mentioned below):	
4800-4	022298
VW-Golf 2, AUDI, PORSCHE, SMART	
4800-5	022304
VW-Passat, Golf-Diesel, Lupo since 1998	
4800-6	022311
OPEL, DAEWOO, FORD Sierra	
4800-7	022328
BMW 5- and 7-series	
4800-8	022335
BMW 3-series, Z3, Range-Rover	
4800-9	022342

Tester for Cooling Systems



Options for assortments:
Adapters for Radiator

HAZET No.	EAN-No. 4000896+
RENAULT	
4800-10	022250
Japanese cars, e.g. KIA	
4800-11	022267
AUDI A 2, A 3, A 4, A 6, TT, VW-Passat, Golf, Vento	
4800-12	057832
VW-Sharan, FORD-Galaxy, AUDI A 8 since 2002	
4800-13	057849
MERCEDES-BENZ type 168 (A-class), CDI, 220, 129	
4800-14	079018
MERCEDES-BENZ type 202 / 203 (C-class) 124 / 210 (E-class) and 129 / 220 (S-class)	
4800-15	079025
MERCEDES-BENZ SLK, CLK, Sprinter since 1999 type 170, 208, 611	
4800-16	098507
OPEL Vectra C	
4800-17	109661

Universal Adapters



HAZET No.	EAN-No. 4000896+
for radiator openings \varnothing 20 – 41 mm, with 3-stage rubber for rough and precise adjustment	
4800-30	078202
especially for Japanese vehicles \varnothing 18 – 24 mm with clamp fastening	
4800-31	078196

Coolant Thermometer



- For the Tester for Cooling System HAZET 4800 for testing the water temperature, the thermostat and the water temperature indicator
- With rubber plug to joint with coupling fitting

HAZET No.	l mm	EAN-No. 4000896+
4800-40	170	058907

Cylinder Head Leakage Tester



- For the Tester for Cooling Systems HAZET 4800
- For the detection of damaged cylinder heads
- For the easy detection of leakage in the connection between combustion chamber and cooling system on water-cooled engines (gas, diesel and gasoline)
- With reaction fluid

HAZET No.	EAN-No. 4000896+
4800-41	058891
Reaction fluid	
4800-041	108985

Optical Tester



- For the control of the **anti-freezing acid concentration** in the cooling system (\pm 1 %) (as well as for cooling fluid G 11 and G 12 VOLKSWAGEN/AUDI)
- For the control of the **battery acid concentration (\pm 10 g/l)** (battery charging)

HAZET No.	mm	EAN-No. 4000896+
4810 B	162	083541



Endoscope



- For damage diagnosis
- 4 times brighter than conventional endoscopes
- Continuous focussing of the eyepiece
- High-resolution transmitter with more than 7000 optical fibers
- Wide field of view due to wide aperture angle
- Very small bending radius (30 mm) for areas with restricted access
- Specially coated achromatic optics for pictures without colour fringes
- On/off switch with continuous light regulation
- Water-proof endoscope probe – allows even short-time use in oil or gasoline
- Cold light lamp tip – no danger of inflammation in hollow spaces with explosive gas mixtures
- Patented connector allows fast adaptation of the battery handle to the basic appliance
- Temperature range: -20 up to +55°C
- Eyepiece cup for spectacle wearers
- Practical storage box with additional empty compartments e.g. for small parts
- Possible applications:
 - Gear damages and wear marks
 - Axle wear
 - Cylinder wall / piston head
 - Valves
 - Hollow spaces (e.g. hollow shanks, sliding-roof, cavities)
- Useful length 1000 mm
- Outside diameter 6 mm
- Brightness up to 50,000 lux at a distance of 16 mm
- Minimum working distance 10 mm
- 90° Side View Adapter 4811-2 (optional) can be screwed on
- Battery handle with 3 LR 14 dry-batteries

HAZET No.	EAN-No. 4000896+
4811-1/2	109678
90°-Mirror (Side-View Adapter)	
• Extends the field of view to a 90° aperture angle	
• Outside diameter of the endoscope remains the same	
• Tight screwing for safe fixation (unloosable)	
4811-2	109685
Spare lamp	
4811-01	110377

Socket with Universal Joint



- For installing and removing the temperature probe on MERCEDES-BENZ Sprinter
- □ 10 = 3/8"
- Chrome-Vanadium
- Surface chrome-plated

HAZET No.	S mm	l mm	EAN-No. 4000896+
4813 G-19	19	64	100668

6-Point Socket



- For installing and removing the thermal switch at the radiator fan on OPEL Corsa B, Astra F, G, Vectra A, B
- With deep relief
- With side groove for the operation of switches with extension cable or guiding pin
- □ drive 12.5 = 1/2"
- s 6-point 29 mm
- Chrome-Vanadium
- Surface chrome-plated

HAZET No.	S mm	EAN-No. 4000896+
4815-29	29	082735

Wiper Adjusting Tool



For angular adjustment of the wiper blades – consider the regulations of car manufacturer – Not suitable for A-Aerotwin wipers

HAZET No.	l mm	EAN-No. 4000896+
4851-1	120 x 65 x 60	048212

6-Point Socket



- For installing and removing the oil pressure switch on OPEL Zafira and Astra 1.8 16 V, ESP pressure sensor SMART Roadster, rear axle gear Maybach
- □ 12.5 = 1/2"
- s 24 mm, with Traction profile
- Outside-φ 30.7 mm
- Chrome-Vanadium
- Surface chrome-plated

HAZET No.	S mm	l mm	EAN-No. 4000896+
4815-24	24	85	100583

BODY AND FENDER

Nozzle Adjusting Tool



- For adjusting the nozzles of the washing system
- The telescopic handle can be used to demonstrate the jet of the nozzles to the window
- With magnetic head 6 mm φ
- Adjusting needle and protective cap
- Pocket-clip

HAZET No.	l mm	EAN-No. 4000896+
4850-1	155-670	022366

Window Extracting Knife



- Knife with pulling handle
- For the extraction of glued car windows

HAZET No.	EAN-No. 4000896+
4852-1	050543

Spare blades, set with 2 parts
22 mm depth of cut

4852-01/2	051496
-----------	--------

Spare blades, set with 2 parts
15 mm depth of cut

4852-02/2	056446
-----------	--------

HAZET Safety Spring Vice 4900

... everything fits well and your safety is guaranteed!



- Extremely high capacity 26000 N
- Suitable for impact wrenches
- Maintenance-free
- Application possible even when strut unit is installed



You'll find a current and comprehensive classification table according to the types of vehicles on our homepage www.hazet.com: "Products" – "Product Info".

Safety Spring Vice

H.I.T.S.



- For installing and removing the coil spring when replacing shock absorbers
- **max. span 309 mm**
- **Permissible load of 26,000 N**
- **Suitable for impact wrenches**, e.g. HAZET 9012 MG in conjunction with HAZET Sockets 900 S-27 or 900 S Lg-27
- Closed system – **maintenance-free!**
- Variable system due to easily replaceable tensioning jaws (DBGM – German registered utility model)
- Plastic inserts for the protection of lacquered spring surfaces. Through this, corrosion of the spring can be avoided.
- **With location bar**
- Proven safety
- Tempered cylindrical guiding tube
- Forged and tempered tensioning jaws
- European Patent applied
DBGM – German registered utility model and protected by design patent

Classification table according to types of vehicles see following page as well as in the internet: www.hazet.com

HAZET No.	EAN-No. 4000896+
4900-2 A	077267



Safety Shearing Pin

4900-01	056125
Replacement set for Spring Vice 4900-1 A and -2 A consisting of 5 straight pins and 2 O-rings	
4900-02/7	063437
Replacement set for Spring Vice 4900-1 A and -2 A consisting of 2 straight pins and O-ring	
4900-02 A/3	069415

Pairs of Tensioning Jaws



for Safety Spring Vice

ALFA-ROMEO, FIAT, FORD, NISSAN, PORSCHE, SEAT, SUZUKI, VOLKSWAGEN

HAZET No.	EAN-No. 4000896+
4900-10/2	060474

Plastic Spring Protection Insert

price apiece

4900-100	061136
----------	--------



AUDI, BMW, CHRYSLER, DAEWOO, FIAT, FORD, ISUZU, NISSAN, OPEL, PEUGEOT, PORSCHE, RENAULT, SEAT, SKODA, TOYOTA, VOLKSWAGEN

HAZET No.	EAN-No. 4000896+
4900-11/2	060481

Plastic Spring Protection Insert

price apiece

4900-110	061143
----------	--------

Pairs of Tensioning Jaws



AUDI, BMW, CHRYSLER, FIAT, HONDA, NISSAN, OPEL, PEUGEOT, RENAULT, TOYOTA, VOLKSWAGEN, VOLVO

HAZET No.	EAN-No. 4000896+
4900-12/2	060498

Plastic Spring Protection Insert

price apiece

4900-120	061150
----------	--------



ALFA ROMEO, AUDI, CHRYSLER, FIAT, NISSAN, MAZDA, PEUGEOT, RENAULT

HAZET No.	EAN-No. 4000896+
4900-13/2	060504

Plastic Spring Protection Insert

price apiece

4900-130	061167
----------	--------



MERCEDES-BENZ E-class 4MATIC, type 210

HAZET No.	EAN-No. 4000896+
4900-14/2	051984



MERCEDES-BENZ A-class, PORSCHE

HAZET No.	EAN-No. 4000896+
4900-15/2	060443



MERCEDES-BENZ ML-class, CHRYSLER

HAZET No.	EAN-No. 4000896+
4900-16/2	060450



MERCEDES-BENZ Vito, V-class, CHRYSLER

HAZET No.	EAN-No. 4000896+
4900-17/2	060467

Pair of Tensioning Jaws



incl. Plastic Spring Protection Insert
MERCEDES-BENZ front axle C-class, type 203 since 2000

HAZET No.	EAN-No. 4000896+
4900-18/3	100385



incl. Plastic Spring Protection Insert
BMW rear axle
E 65: 735i, 745i, 730d, 740d
E 66: 735Li, 745Li ab Bj. 2001

HAZET No.	EAN-No. 4000896+
4900-19/4	090082

Plastic Spring Protection Insert

price apiece

4900-190	086153
----------	--------



incl. Plastic Spring Protection Insert
BMW 3 series (E 46) since 1998

HAZET No.	EAN-No. 4000896+
4900-22/4	061051

Plastic Spring Protection Insert

price apiece

4900-220	061013
4900-240	061037



incl. Plastic Spring Protection Insert
BMW 7 series (E 38) since 1993

HAZET No.	EAN-No. 4000896+
4900-23/4	061044

Plastic Spring Protection Insert

price apiece

4900-230	061020
----------	--------

Plastic Spring Protection Insert

Special insert in conjunction with HAZET Tensioning Jaws 4900-23 and Safety Spring Vice 4900-2 A for the operation of the front axle springs on BMW since 2001
E 65: 735i, 745i, 730d, 740d
E 66: 735Li, 745Li
DBGM – German registered utility model
price apiece

4900-231	088959
----------	--------



Classification of tools: (For more information see page 143 and in the internet: www.hazet.com)

- = no Safety Spring Vice necessary
- * = no information available at this moment
- ** = Only use BMW coil springs in combination with the corresponding plastic spring protection inserts. BMW regulations: Use Spring Vice with manual tools only.

Technical data are subject to change without notice

ALFA ROMEO			
Alfa 156	1998-	4900-10	*
Alfa 164 Super	1996	4900-13	*
AUDI			
100 Quattro	1989-1993	4900-13	4900-11, 12
100 C4	1989-1993	4900-13	4900-11
80	1989	4900-11	*
80 B4	1992	4900-11	*
A100	1991	4900-13	*
A2	2000	4900-11	*
A3	2000	4900-11	*
A4	1996	4900-11	*
A4 Vario	1996	4900-11	*
A6	1996	4900-11	*
A8	1996	4900-11	*
BMW			
3 (E36) **	1989-1998	4900-12	*
3 (E46) **	1998-	4900-22/4	*
5 (E34) **	1994	4900-11	-
528i (E39) **	1995	4900-12	*
530i+540i (E39) **	1996-	4900-23/4	*
7 (E38) **	1993-	4900-23/4	*
730i (E32) **	1985-1994	4900-11	-
Z3 **	1996-	4900-12	*
CHRYSLER			
300M (LH)	1998-	4900-12	4900-11
Cherokee (XJ)	1993-	4900-11	*
Grand Cherokee (ZJ, ZG, WJ)	1993-	4900-11	*
Neon (PL)	1997-	4900-12	4900-17
Stratus (JA/JX)	1996-	4900-16	*
Voyager (GS)	1996-	4900-13	*
Wrangler (TJ)	1997-	4900-11	*
DAEWOO			
Nexia	1997	4900-11	*
Nubira	1998-	4900-11	*
FIAT			
Barchetta	1995	4900-12	*
Ducato	1995	4900-13	*
Marea	1997	4900-13	*
Panda	1993	4900-10	*
Punto	1997	4900-10, 12	*
Seicento Sporting	1998	4900-12	*
Stilo	2002	4900-11	*
Tempra	1993	4900-12	*
Tipo	1990	4900-13	*
Ulysse	1994	4900-13	*
FORD			
Escort	1988	4900-10	*
Escort 1,4i	1988	4900-10	*
Fiesta	1989-1995	*	4900-10
Fiesta	1996	4900-11	*
Focus	1998	4900-11	*
Mondeo	1996	*	4900-11, 12
Puma	1998-	4900-11	4900-10
Sierra	1991	4900-11	*
HONDA			
Accord Coupé	*	4900-12	4900-12
ISUZU			
Gemini	1988	4900-11	*
MAZDA			
626	1992	4900-13	4900-11
MERCEDES-BENZ			
A-Klasse / class A	1997-	4900-15	4900-14
E-Klasse 4MATIC / class E	1997-	4900-14	-
ML-Klasse / class ML	1997-	-	4900-16
Vito, V-Klasse / class Va	1996-	4900-17	-
NISSAN			
Almera (N15)	1996	4900-11	4900-10
Bluebird (T12)	1985-1990	4900-13	4900-12
Laurel (C32)	1984-1990	4900-12	4900-10
Micra (K10)	1982-1992	4900-10	4900-10
Micra (K11)	1992-	4900-10	*
N200SX (S14)	1994	4900-13	4900-11
Prarie (M11)	1988-1994	4900-13	4900-13
Primera (P11)	1996	4900-10, 11	4900-10
Primera (W10)	1990	4900-11	*

NISSAN				
Serena (C23)	*	4900-13	*	
OPEL				
Ascona C	1989	4900-12	*	
Astra F	1991-1998	4900-11	*	
Astra G	1998-1999	4900-11	4900-11	
Calibra A	1994	4900-12	*	
Corsa A	1987	4900-11	*	
Corsa B	1997	4900-11	*	
Kadett E	1989	4900-11	*	
Omega A	1987	4900-12	*	
Omega B	1997	4900-12	*	
Sintra	1998	4900-12	*	
Tigra	1996	4900-11	4900-11	
Vectra A	1994	4900-12	*	
Vectra B	1996-	4900-12	*	
Zafira	1999-	4900-12	*	
PEUGEOT				
106	1997	4900-12	*	
205	*	4900-12	*	
206	1992	4900-12	*	
406	1997	4900-12	*	
505	1983	4900-12	*	
806	1999	4900-13	4900-11	
Boxer	*	4900-13	*	
PORSCHE				
911 Carrera RS (Type 993)	1995 -	4900-16	4900-14	
911 Turbo / Carrera 2/4 (Type 964)	1989 - 1993	4900-16	4900-14	
911 Turbo / Carrera 2/4 (Type 993)	1993 - 1998	4900-16	4900-16	
924 S	1982 - 1991	4900-10	-	
928 / 928 S / 928 S4 / 928 GTS	1978 - 1995	4900-15	4900-15	
944 / 944 S / 944 S2 / 944 Turbo	1982 - 1991	4900-10	-	
968	1992 - 1995	4900-10	-	
Boxster / Boxster S (Type 986)	1996 -	*	4900-11	
Carrera 2/4 / Turbo (Type 996)	1998 -	*	4900-16	
RENAULT				
Clio	1993-1995	4900-11	*	
Espace	1993	4900-12	*	
Mégane	1996	4900-11, 12	*	
R19	1990	4900-12	*	
R21	1991	4900-13	*	
R5	1992	4900-11	*	
Rapid	1994	4900-11	*	
Twingo	1998	4900-11	*	
SEAT				
Ibiza	1992	4900-11	*	
Ibiza GL	2002	4900-11	4900-10	
Leon	2002	4900-11	4900-10	
Toledo	1996	4900-11	*	
SKODA				
Fabia	*	4900-11	*	
Octavia	1999	4900-11	*	
Superb	*	4900-11	*	
SUZUKI				
Alto	1993	4900-10	*	
TOYOTA				
Camry 3,0	1992	4900-12	*	
Corolla	*	*	4900-11, 12	
VOLKSWAGEN				
Golf I + II	1984-1992	4900-10	*	
Golf II 1,3L	1983-1992	4900-10	4900-11	
Golf III	1992-1997	4900-11	*	
Golf IV	1998	4900-11	4900-10	
Jetta	1989	4900-11	*	
Lupo	1999	4900-11	4900-10	
Passat	1986	4900-11	*	
Passat	1990	4900-11	*	
Passat	1992	4900-11	*	
Passat B5	1997	4900-11	*	
Passat Variant	1993	4900-11	4900-10	
Polo	1994	4900-11	*	
Polo I	1989-1992	4900-11	*	
Sharan	1996	*	4900-12	
VOLVO				
S 80	*	4900-12	4900-12	

Shock Absorber Tool Assortment

(E) H.I.T.S.



- For repair work at the spring strut e.g. shock absorber, bearings of shock absorber legs, coil springs
- For retaining the piston rod when installing or removing strut units
- **Caution:**
Consider torque regulations of car manufacturer, always use a Torque Wrench e.g. HAZET 6121-1 CT in conjunction with Box Insert Tool 6630 d-21! Application of an impact wrench may damage the support bearing and the piston rod

HAZET No.	S mm	EAN-No. 4000896+
-----------	------	------------------

Set with 13 parts in plastic box

contents:

4910-1	4910-6	7	8
4910-16	17	18	19 21 22 24
4910-58	68		

4910/13	061495
---------	--------

Reversible Ratchet

4910-1	062133
--------	--------

Repair Set consisting of:

ratchet wheel, complete, pawl, shift lever, 2 screws, ball and compression spring for 4910-1

4910-1/7	064533
----------	--------

Extensions

4910- 6	○ 6	062089
4910- 7	○ 7	062096
4910- 8	○ 8	062102
4910-58	● 5 x 8	062119
4910-68	● 6 x 8	062126

For PORSCHE Cayenne S, VW-Touareg

4910-71	● 7,1 x 9,6	091195
---------	-------------	--------

6-Point Sockets

4910-16	16	062010
4910-17	17	062027
4910-18	18	062034
4910-19	19	062041
4910-21	21	062058
4910-22	22	062065
4910-24	24	062072

6-Point Sockets



- For repair work at the spring strut especially for retaining the piston rod when installing or removing strut units
- In conjunction with the HAZET Shock Absorber Tool Assortment 4910/13

HAZET No.	S mm	EAN-No. 4000896+
-----------	------	------------------

s 7 mm for MERCEDES-BENZ Vaneo screws at the joint rod

4911-7	● 7	100620
--------	-----	--------

s 8 mm for BMW

4911-8	● 8	085644
--------	-----	--------

s 9 mm for OPEL Corsa B, Astra F, G, Vectra B

4911-9	● 9	100804
--------	-----	--------

Wheel Bearing Extractor

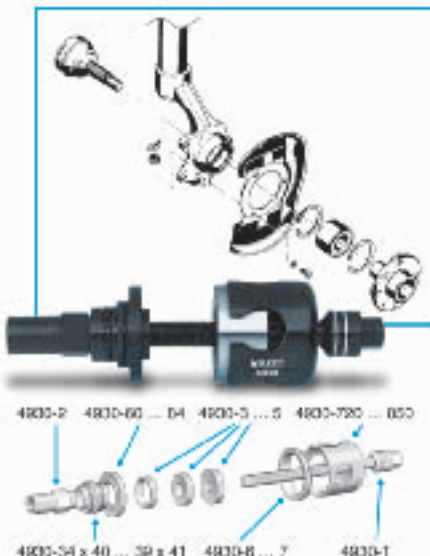

- For the **change of built-in wheel bearings** – removing of strut unit as well as adjustment of king pin inclination is not necessary –
- Patented function of adapters
- Axial guidance due to centering bushing
- Centering aid due to calotte (spherical recess) of the housing
- High-quality threaded spindle with high capacity
- In tool case (expandable)
- With operating instructions
- DBGm – German registered utility model, EP

HAZET No.	EAN-No. 4000896+
-----------	------------------

Threaded spindle
incl. thrust bearing,
6-point drive s 22

4930-1	080755
--------	--------

Spindle nut s 30

4930-2	080762
--------	--------

Spacer plates

4930-3	081158
4930-4	081141
4930-5	082834

Reduction rings

 4930-6 for VW-Polo C since 1991,
PEUGEOT 106 since 1999

4930-6	083633
--------	--------

4930-7	083640
--------	--------

4930-8	097890
--------	--------

Centering bushings

4930-34 x 40	081042
4930-35 x 40	081066
4930-35 x 42	081035
4930-37 x 45	081073
4930-39 x 41	081028
4930-43 x 45	097739

Thrust washers burnished

outside ϕ 60 mm	
----------------------	--

4930-60	081011
---------	--------

outside ϕ 62 mm	
----------------------	--

4930-62	080854
---------	--------

outside ϕ 64 mm	
----------------------	--

4930-64	080939
---------	--------

outside ϕ 66 mm	
----------------------	--

4930-66	080946
---------	--------

outside ϕ 68 mm	
----------------------	--

4930-68	080953
---------	--------

outside ϕ 72 mm	
----------------------	--

4930-72	080960
---------	--------

outside ϕ 74 mm	
----------------------	--

4930-74	080977
---------	--------

Wheel Bearing Extractor



HAZET No.	EAN-No. 4000896+
-----------	------------------

Thrust washers burnished

outside ϕ 74 mm	
----------------------	--

4930-74	080977
---------	--------

outside ϕ 80 mm	
----------------------	--

4930-80	081004
---------	--------

outside ϕ 82 mm	
----------------------	--

4930-82	080991
---------	--------

4930-8245	097746
-----------	--------

outside ϕ 84 mm	
----------------------	--

4930-84	081448
---------	--------

Housings, burnished:

72 mm ϕ	
--------------	--

4930-720	081080
----------	--------

82 mm ϕ	
--------------	--

4930-820	081097
----------	--------

85 mm ϕ	
--------------	--

4930-850	082179
----------	--------

Wheel Bearing Extractor Sets

in box

HAZET No.	EAN-No. 4000896+
-----------	------------------

15 parts for VW/AUDI, OPEL, FORD

contents:

4930-1	2	3	4
4930-34 x 40	35 x 40	39 x 41	
4930-62	64	66	68 72 74
4930-720	820		

4930-1/15	082636
-----------	--------

15 parts for RENAULT, PEUGEOT, CITROËN (PSA)

contents:

4930-1	2	3	4	5
4930-35 x 40	35 x 42	37 x 45		
4930-64	72	82	84	4930-720 820 850

4930-2/15	082766
-----------	--------

14 parts for VW/AUDI, SEAT, SKODA

contents:

4930-1	2	3	4
4930-34 x 40	35 x 40	39 x 41	
4930-62	66	68	72 74 4930-720 820

4930-25/14	082568
------------	--------

12 parts for MERCEDES-BENZ

contents:

4930-1	2	3	4	5	7
4930-35 x 42	37 x 45		4930-64	74	84 850

4930-27/12	084234
------------	--------

12 parts for BMW

contents:

4930-1	2	3	4
4930-35 x 42	37 x 45	39 x 41	
4930-72	74	80	4930-720 820

4930-29/12	082575
------------	--------

11 parts for OPEL

contents:

4930-1	2	3	4	4930-34 x 40	39 x 41
4930-64	72	74	4930-720	820	

4930-30/11	082582
------------	--------

Wheel Bearing Extractor Sets

in box

HAZET No. EAN-No. 4000896+

10 parts for FORD

contents:
4930-1 2 3 4 4930-35 x 40 39 x 41
4930-72 74 4930-720 820

4930-34/10 082599

10 parts for PEUGEOT

contents:
4930-1 2 3 4 5 4930-35 x 42
4930-72 82 4930-720 820

4930-37/10 082742

12 parts for RENAULT

contents:
4930-1 2 3 4 5 4930-35 x 40 37 x 45
4930-64 72 84 4930-720 850

4930-38/12 082759

Track Rod Wrench



- For the operation of the track rod screwing
- Double, spring-bearing jaw opening prevents slipping off, especially on seized or very tight screws
- Forged design
- Application on BMW series 3 and 5, MERCEDES-BENZ C and E, OPEL Astra, Corsa, Kadett-E, Omega and Vectra, PEUGEOT 3/406, NISSAN, RENAULT, SEAT Ibiza, SKODA Fabia and Octavia, VW Bora, Golf I-IV, Jetta, Polo, Sharan, T4, Vento AUDI 80, 100, A4, A6

HAZET No. S mm EAN-No. 4000896+

4950-13	13	098033
4950-14	14	098040
4950-17	17	098057
4950-19	19	098064
4950-22	22	100712

Caliper Gauge for Brake Drums

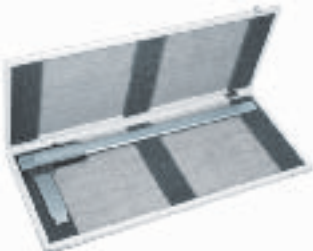

- For the abrasion test at the drum brakes of passenger cars and commercial vehicles
- Slide and rule made of aluminium profile
- Jaws made of stainless steel, 150 mm long
- Inside measuring with immediate reading
- Vernier 1/20
- With fixing screw
- Measuring range 500 mm
- In wooden box

HAZET No. EAN-No. 4000896+

4955-1 073153

Caliper Gauge for Brake Disks



- For measuring the thickness of the brake disks (abrasion test on the brake disk) – please consider the regulations of the car manufacturer –
- With fixing screw and sliding vernier (vernier 1/10)
- With crowned measuring surfaces
- In leather case

HAZET No. EAN-No. 4000896+

for passenger cars and motorcycles, measuring range 60 mm, jaw length 75 mm

4956-1 073160

for commercial vehicles and motorbuses, measuring range 100 mm, jaw length 115 mm

4956-2 073177

Brake Piston Tool



- For complete rotation of pistons with slot in Altecna-Bendix floating calipers, e.g. FIAT, RENAULT
- For floating calipers and first-calipers with integrated parking brake system
- Square 30 x 7 mm
- T-handle, plastic
- Chrome-Vanadium
- Surface chrome-plated

HAZET No. l mm EAN-No. 4000896+

4960-1 145 049905

Brake Piston Setting-Back Device



- For the rotation and unlocking of pistons (with slot) by 45°
- On Gierling floating calipers and first-calipers
- For floating calipers and first-calipers with integrated parking brake system
- Chrome-Vanadium
- Surface chrome-plated

HAZET No. l mm EAN-No. 4000896+

4960-2 205 049912

Mandrels with Abrasive Rings



- For removing rust and dust e.g. from the fit drills of floating calipers or the ABS sensor location hole etc.
- Operation with e.g. a hand drill or flexible extension
- \varnothing 16 mm e.g. for floating calipers on VW Golf, Passat, Polo, etc.

Mandrels with Abrasive Rings

◀

- \varnothing 18 mm e.g. the ABS sensor location hole on BMW, VW-AUDI, etc.
- \varnothing 22 mm e.g. for the floating calipers on OPEL

HAZET No. EAN-No. 4000896+

Mandrel with 50 abrasive rings

4961-16/51 099313

4961-18/51 099320

4961-22/51 099634

Mandrel

4961-16 099528

4961-18 099535

4961-22 099542

25 abrasive rings

4961-016/25 • 111565

4961-018/25 • 111572

4961-022/25 • 111589

50 abrasive rings

4961-016/50 099559

4961-018/50 099566

4961-022/50 099573

Special Tool for Brakes

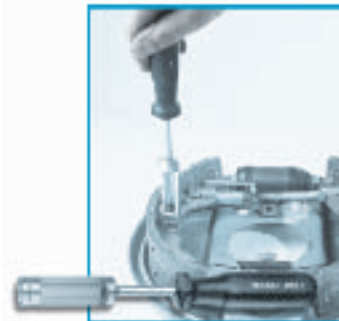

- For installing and removing spring plates the holding device of brake linings on drum brakes e.g. on VW, SEAT, SKODA, OPEL and RENAULT with rear drum brakes
- Push- and turn-part with carbide coating layer in front working area
- Plastic handle
- Chrome-Vanadium
- Surface chrome-plated

HAZET No. l mm EAN-No. 4000896+

4963-1 237 050383

Assembly Tool



- For installing and removing the **draw spring of hand brake shoes** e.g. on MERCEDES-BENZ passenger cars with rear disk brakes
- Hook with T-Handle
- Special steel
- Surface chrome-plated

HAZET No. EAN-No. 4000896+

4964-1 055708

Brake Adjusting Tool



- For **adjusting hand brakes** (brake cable) on different car models, especially for VW-AUDI, BMW, FORD, OPEL-Astra G, Vectra B and MAZDA
- Tubular box wrench ≤ 10 mm
- Plastic handle
- Chrome-Vanadium
- Surface chrome-plated

Not suitable for vehicles with automatic hand brake adjusting

HAZET No.	s mm	l mm	EAN-No. 4000896+
4965-1	10	300	050598

Insert Tools



- For screwing the union nuts on brake lines on BMW, VW-AUDI, FORD, MERCEDES-BENZ, MITSUBISHI, NISSAN, PEUGEOT, RENAULT, VOLVO
- also on vehicles without antilocking system
- Flare nut insert tool
- □ drive 6.3 = 1/4" or square insert 9 x 12 mm
- Chrome-Vanadium
- Surface chrome-plated

HAZET No.	s mm	EAN-No. 4000896+
4966-11	11	059010
4966-12	12	059027

Caliper File



- For removal of brake dust, rust and dirt from the caliper shaft
- On vehicles with disk brakes
- Coarse bevel cut on one side
- One-sided cut prevents damage of dust boot
- 12 mm wide
- Plastic handle
- Special steel

HAZET No.	l ₁ mm	l ₂ mm	EAN-No. 4000896+
4968-1	150	260	084739

Brake Caliper Brush



- For removal of brake dust and dirt from the caliper shaft
- On vehicles with disk brakes
- Slim design
- Plastic handle with suspension hole

HAZET No.	l mm	EAN-No. 4000896+
4968-2	225	084821

Brake Caliper Brush



- For cleaning **aluminium brake calipers**
- Soft brass bristles facilitate damage-free cleaning
- Slim design – allows working in areas with restricted access
- Plastic handle with suspension hole

HAZET No.	EAN-No. 4000896+
4968-3	089147

Brake Cable Spring Pliers



- For installing and removing **hand brake cables** of the drum brake
- With opening spring and stop
- Front working area hardened
- Special steel
- Surface burnished

HAZET No.	l mm	EAN-No. 4000896+
4968-4	227	084760

Brake Bleeding Wrenches



- For **brake releasing without removing the wheels**, replacement of wheel brake cylinder, master brake cylinder and tube connections
- Bent and offset
- Equal hexagon span on both sides
- Chrome-Vanadium
- Surface chrome-plated

HAZET No.	l mm	EAN-No. 4000896+
4968- 7	190	085705
4968- 8	208	085699
4968- 9	208	085682
4968-10	236	085712
4968-11	236	085729

	s mm				
BMW	7				
CITROËN	8	9			
DAIHATSU	8				
FIAT	7	8*			
FORD	7	8	9	10	11
HONDA	8				
MAZDA	8				
MERCEDES-BENZ	9*				
MITSUBISHI	10				
NISSAN	10*				
OPEL	9*				
PEUGEOT	7	8	9	10	11
RENAULT	7	8*	9	11	
SEAT	7	8*			
SUZUKI	10				
TOYOTA	8*				
VOLVO	8	10	11		
VW-AUDI	7	11*			

* especially for the new car models

Brake Bleeding Wrench Set



5 parts, 7-11 mm

contents:
4968-7 8 9 10 11

HAZET No.	EAN-No. 4000896+
4968/5	086535

Brake Piston Readjusting Set

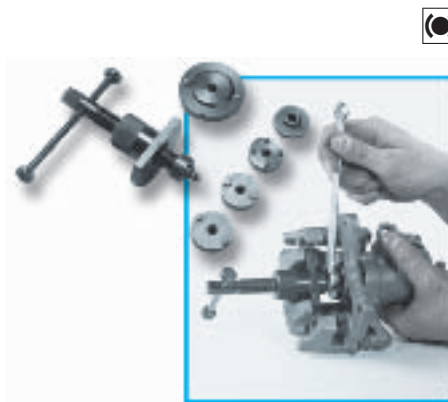

with thrust bearing rotating to the left and right

- For readjusting (**pushing or turning**) brake pistons on floating cylinder systems with or without locking device for hand brakes
- Thrust bearing avoids damaging of the dust boot
- With additional outside hexagon ≤ 13 mm for flexible application of operating tools, e.g. reversible ratchets
- Universal application – suitable for all common vehicle types

HAZET No.	d mm	EAN-No. 4000896+
-----------	------	------------------

Set with 6 parts in plastic box

contents:
4970-1 5 6 7 8 9

4970/6	–	088867
--------	---	--------

Basic device

4970-1	–	088874
--------	---	--------

Adapter with 2 pins AUDI 80 B4

4970-5	35	052943
--------	----	--------

Adapter VW-AUDI, inside hexagon 12 mm

4970-6	30	052950
--------	----	--------

Adapter with 2 points FORD Focus, SMART for four OPEL Zafira, Astra G, Corsa GSi

4970-7	32	052967
--------	----	--------

Adapter with 2 pins CITROËN, VW-AUDI

4970-8	55	052974
--------	----	--------

Adapter with 4 pins HONDA/SAAB

4970-9	30	052981
--------	----	--------

www.hazet.com

HAZET Torque Tools

high-precision tools up to the last detail

System 5000 CT

- Accuracy $\pm 4\%$ of scale value
- Safe – torque value locking at handle
- Exact – precise scale graduation
- Individual serial number
- Ratchet with sliding square tang
- Tested – with certificate
- Ergonomic



System 6000 CT

- Accuracy $\pm 2\%$ of scale value
- Tested – with certificate
- Safe – torque value locking at handle
- Exact – precise scale graduation
- Individual serial number
- Reversible ratchet
- Ergonomic
- Safety:
 - Haptic (close-gap release)
 - Audible (click point)
 - Visible (signal transmitter, depending on the Torque Wrench)

... and who will be checking your HAZET Torque Wrench?



Examination and Calibration Service for HAZET Torque Wrenches

Our Examination and Calibration Service offers:

- Good preconditions for functional Torque Wrenches
- Regular working quality, provable in the long term
- Indication of Torque Wrenches with examination badge
- Examination certificates indicating the test values



Torque Wrenches • SYSTEM 5000 CT • Release accuracy ± 4%

SYSTEM 5000 CT

- Release accuracy tolerance ± 4% of scale value (in direction of actuation)
 - Tightening at torque setting is possible both to the right and the left
 - With automatic close-gap release, palpable and audible when torque setting is reached
 - Turn handle to adjust the desired torque value easily and safely
 - With lock at the handle
 - Fine scale graduation
 - With serial number and certificate
 - Ratchet with sliding square tang (according to DIN 3120 A, ISO 1174-1 A) with plastic turn-knob for manual pre-tightening
 - Reversible sliding square tang allows changement of direction of actuation
 - DIN EN ISO 6789
 - DBGM – German registered utility model, EP
- + = Safe Box available, to be ordered separately

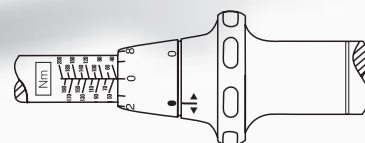
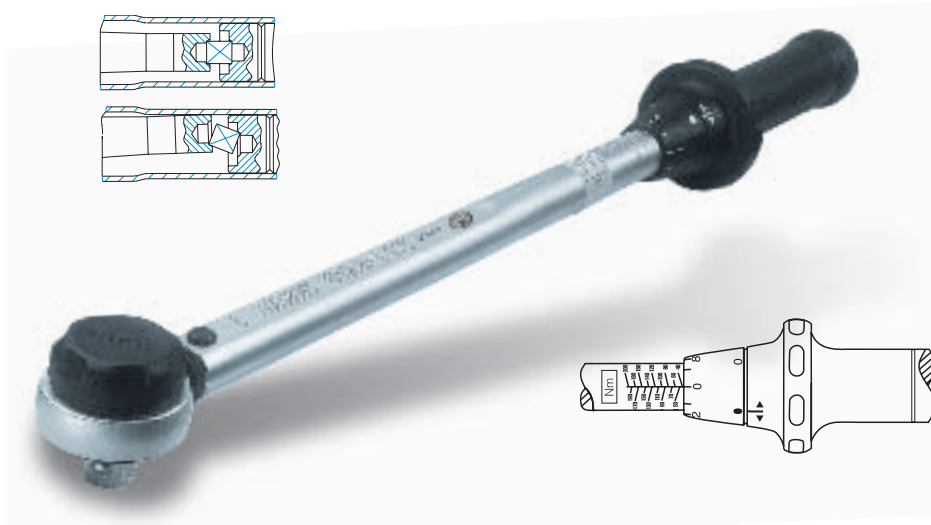
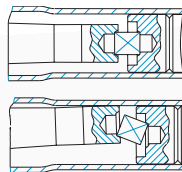
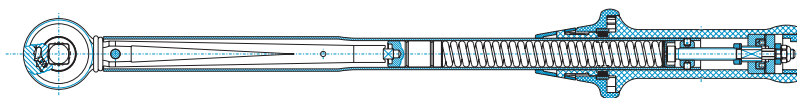

HAZET No.	■	Nm	l mm	EAN-No. 4000896+
5110-1 CT +	10 = 3/8"	10- 60	300	022397
5121-1 CT +	12,5 = 1/2"	20-120	392	022427
5122-1 CT +	12,5 = 1/2"	40-200	498	022472
5123-1 CT	12,5 = 1/2"	60-320	615	022588



Sliding square tang 10 = 3/8" ■ for 5110-1 CT

5110-01 36 049691

Sliding square tang 12.5 = 1/2" ■ for 5121-1 CT, 5122-1 CT 5123-1 CT

5121-01 48 022410

Torque Wrenches – Graduation				Torque Wrenches – Graduation			
Range	Graduation	HAZET No.		Range	Graduation	HAZET No.	
10 - 120 cNm	1 cNm	6002 CT		5 - 40 lbf.ft	0,5 lbf.ft	6114-1 CT	
1 - 6 Nm	0,1 Nm	6003 CT		(6,8 - 54,2 Nm)	(0,7 Nm)		
2 - 10 Nm	0,2 Nm	6108-1 CT		20 - 100 lbf.ft	0,5 lbf.ft	6115-1 CT	
		6280-1 CT		(27,1 - 135,6 Nm)	(0,7 Nm)		
4 - 40 Nm	0,4 Nm	6109-2 CT		40 - 200 lbf.ft	1 lbf.ft	6127-1 CT	
		6282-1 CT		(67,8 - 339 Nm)	(1,4 Nm)		
5 - 60 Nm	0,5 Nm	5110-1 CT		50 - 250 lbf.ft	2 lbf.ft	6128-1 CT	
		6290-1 CT		(67,8 - 339 Nm)	(2,7 Nm)		
10 - 60 Nm	0,5 Nm	6110-1 CT		120 - 600 lbf.ft	2 lbf.ft	6123-1 CT	
		6290-1 CT		(162,7 - 813,5 Nm)	(2,7 Nm)		
20 - 120 Nm	1 Nm	5121-1 CT, 5121-2 CLT, 6111-1 CT, 6121-1 CT, 6191-2 CT, 6291-1 CT					
40 - 200 Nm	1 Nm	5122-1 CT, 5122-2 CLT, 6122-1 CT, 6292-1 CT					
60 - 320 Nm	2 Nm	5123-1 CT, 5123-2 CLT, 6123-1 CT, 6293-1 CT					
100 - 400 Nm	2,5 Nm	6143-1 CT, 6294-1 CT					
200 - 500 Nm	2,5 Nm	6144-1 CT, 6295-1 CT					
300 - 800 Nm	2,5 Nm	6145-1 CT, 6296-1 CT					

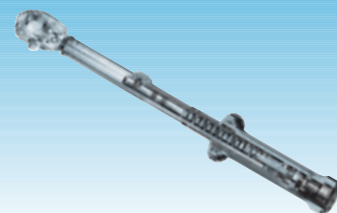

Torque Wrenches • SYSTEM 5000 CLT • Release accuracy ± 4%

- Click-Lens-Type
Large digits for exact and easy-to-read torque setting
- Easy and safe adjusting of the desired torque value
Exact and easy reading of the torque value
- Triple-digit optomechanical value readout with large digits on the display
- Torque release
– palpable – by close-gap release
– audible – by click-sound
- Release accuracy ± 4% of the preset value
- Large, convex display (exchangeable) simplifies reading
- The desired torque value is adjusted easily and safely by turning the handle
- Reversible ratchet
- Ergonomically shaped handle
- Safety lock at the handle
- With serial number and certificate
- DBGM – German registered utility model, EP

HAZET No.	■	Nm	lbf. ft.	l mm	EAN-No. 4000896+
5121-2 CLT	12,5 = 1/2"	20-120	-	435	104215
5122-2 CLT	12,5 = 1/2"	40-200	-	545	104192
5123-2 CLT	12,5 = 1/2"	60-320	-	660	104222
5128-2 CLT	12,5 = 1/2"	-	50-250	660	112296

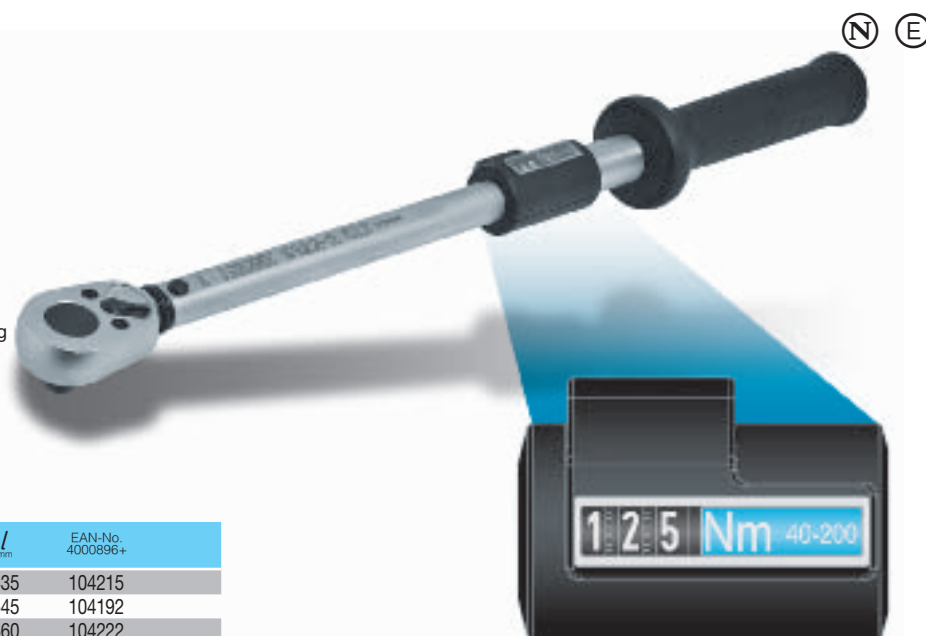

Repair Sets see page 152

Dynamometric Screwdrivers • SYSTEM 6000 CT • Release accuracy ± 5%

- Release accuracy tolerance ± 5% of scale value (in direction of actuation)
- For Screwdriver Bits with 6.3 = 1/4" outside hexagon drive
- Application of Sockets (□ drive 6.3 = 1/4") in conjunction with Adapter HAZET 2304
- Application on plastic screwed connections and connections on switch cabinets and model making

HAZET No.	□	cNm	Nm	l mm	EAN-No. 4000896+
6002 CT	6,3 = 1/4"	10-120	-	170	023004
6003 CT	6,3 = 1/4"	-	1-6	230	023011



Torque Wrenches • SYSTEM 6000 CT • Release accuracy ± 2%

- With automatic close-gap release, palpable, audible and visible when the torque setting is reached
- Easy and safe adjustment of the desired torque value by turning the handle
- Release accuracy tolerance ± 2% of scale value (in direction of actuation)
- For application on engines, gearboxes, machines, in industry and model making
- DIN EN ISO 6789
- Square according to DIN 3120 A, ISO 1174-1 A

HAZET No.	■	Nm	l mm	EAN-No. 4000896+
6108-1 CT	6,3 = 1/4"	2-10	198	062218
6109-2 CT	6,3 = 1/4"	4-40	256	080564

Repair Sets see page 152

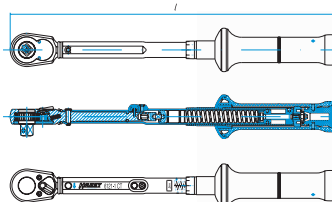

- Release accuracy tolerance ± 2% of scale value (in direction of actuation)
- With reversible ratchet
- With turning knob for supplementary torque value locking
- DIN EN ISO 6789
- Square drive according to DIN 3120 A, ISO 1174-1 A
- 6110-1 CT up to 6123-1 CT = German Patent

+ = in Safe Box
o = without signal transmitter

HAZET No.	■	Nm	l mm	EAN-No. 4000896+
6110-1 CT +	10 = 3/8"	5- 60	335	025022
6111-1 CT +	10 = 3/8"	20-120	389	025077
6121-1 CT +	12,5 = 1/2"	20-120	435	025220
6122-1 CT +	12,5 = 1/2"	40-200	545	025268
6123-1 CT	12,5 = 1/2"	60-320	663	025367
6143-1 CT o	20 = 3/4"	100-400	803	025466
6144-1 CT o	20 = 3/4"	200-500	1040	025541
6145-1 CT o	20 = 3/4"	300-800	1280	025565

Repair Sets see page 152



Torque Wrenches • SYSTEM 6000 CT • US-Standard • Release accuracy ± 3%

- According to US standards
- Scale graduation in lbf.ft
- Release accuracy tolerance ± 3% of scale value (in direction of actuation)
- With reversible ratchet
- With turning knob for additional torque value locking
- Square drive according to DIN 3120 A, ISO 1174-1 A

+ = in Safe Box
o = without signal transmitter

HAZET No.	■	lbf. ft.	Nm	l mm	EAN-No. 4000896+
6114-1 CT	10 = 3/8"	5- 40	6,8- 54,2	333	078424
6115-1 CT +	10 = 3/8"	20-100	27,1-135,6	390	025084
6127-1 CT +	12,5 = 1/2"	40-200	54,2-271,2	545	025381
6128-1 CT	12,5 = 1/2"	50-250	67,8-339	660	076116
6132-1 CT o	20 = 3/4"	120-600	162,7-813,5	1280	078455

Repair Sets see page 152

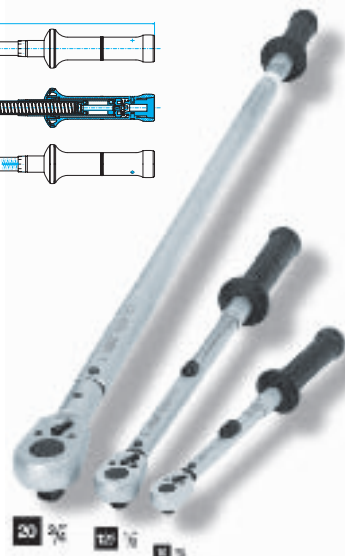
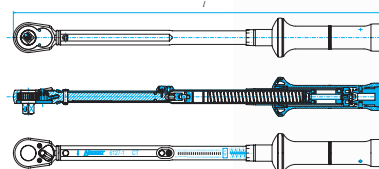

Torque Wrenches • SYSTEM 6000 CT

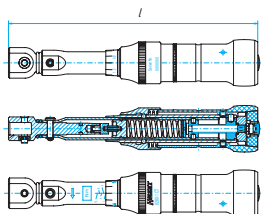

- With plug-and-socket connection to accommodate insert tools
- Release accuracy tolerance in direction of actuation $\pm 2\%$ of scale value
- DIN EN ISO 6789

HAZET No.	□ mm	Nm	l mm	EAN-No. 4000896+
6280-1 CT	9 x 12	2-10	180	026005
6282-1 CT	9 x 12	4-40	240	080540

Repair Sets see page 152



(E)

- With plug-and-socket connection to accommodate insert tools
- Release accuracy tolerance in direction of actuation $\pm 2\%$ of scale value
- DIN EN ISO 6789

+ = in Safe Box

HAZET No.	□ mm	Nm	l mm	EAN-No. 4000896+
6290-1 CT +	9 x 12	5- 60	305	026043
6291-2 CT +	9 x 12	20-120	388	026104
6291-1 CT +	14 x 18	20-120	400	026074
6292-1 CT +	14 x 18	40-200	510	026135
6293-1 CT	14 x 18	60-320	620	026173

Repair Sets see page 152

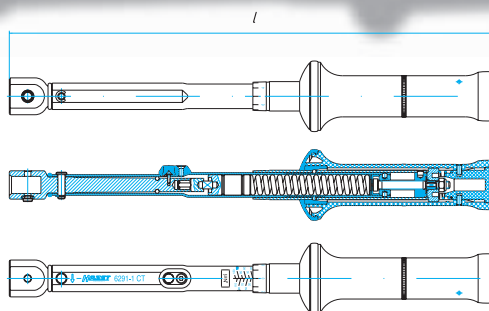
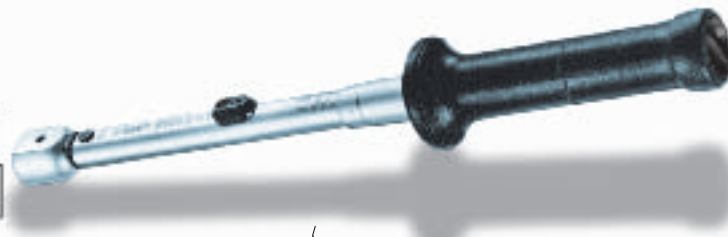
 9 x 12
14 x 18

- With plug-and-socket connection to accommodate insert tools
- Release accuracy tolerance in direction of actuation $\pm 2\%$ of scale value
- DIN EN ISO 6789
- Without signal transmitter

HAZET No.	□ mm	Nm	l mm	EAN-No. 4000896+
6294-1 CT	14 x 18	100 - 400	715	026197
6295-1 CT	14 x 18	200 - 500	955	026203
6296-1 CT	14 x 18	300 - 800	1195	026210

Repair Sets see page 152

14 x 18

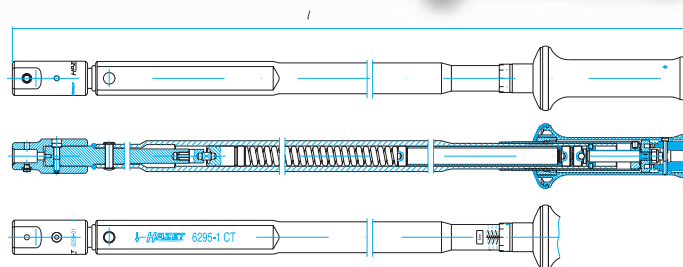

Data for effective length on Torque Wrenches with (different) Insert Tools

MDE = Torque to be selected

MDV = Torque prescribed

l_j = Standard length adjustment with adjusting device

l_1 = Effective length of torque wrench

l_2 = Gauge dimension of adjusting device

l_w = Gauge dimension of extended insert tool

$$MDE = \frac{(l_1 + l_2) \times MDV}{l_1 + l_w}$$

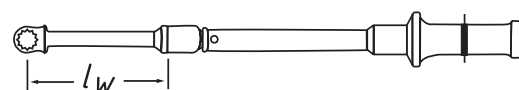
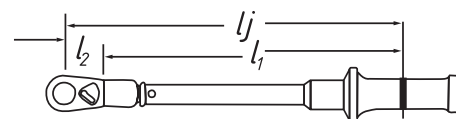

Dimensions of various HAZET Torque Wrenches:

HAZET No.	l mm	Adjusted with HAZET-No.	l mm	HAZET No.	l mm	Adjusted with HAZET-No.	l mm	HAZET No.	l mm
6280-1 CT	135	6401-1 (S)	19,5	6293-1 CT	550	6404-1 (S)	38,5	6391- 35	130
6282-1 CT	195	6401-1 (S)	19,5	6294-1 CT	640	6406	44	6391- 50	190
6290-1 CT	245	6402-1 (S)	30	6295-1 CT	880	6406	44	6391- 85	260
6291-1 CT	330	6404-1 (S)	38,5	6296-1 CT	1120	6406	44	6392-200	345
6291-2 CT	320	6402-1 (S)	30	6391-12	85	-	-	6392-320	570
6292-1 CT	440	6404-1 (S)	38,5	6391-25	130	-	-		

Repair Sets for Torque Wrenches

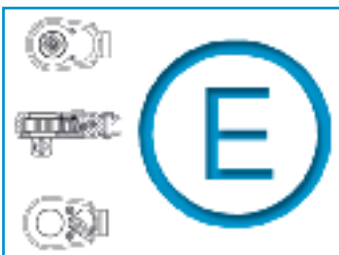

HAZET No. EAN-No. 4000896+

Repair Set for shift lever
 consisting of: shift lever, screws, ball, compression spring
 for 6108-1 CT, 6109-1 CT, 6109-2 CT, 6401-1, 6401-1 S, 6408

6401/5 111176

Repair Set for shift lever
 consisting of: shift lever, screws, ball, compression spring
 for 8816 G, 8816 GK, 8816 P, 8816 S, 8816 ST, 2264-1, 6110 CT, 6110-1 CT, 6111-1 CT, 6114-1 CT, 6115-1 CT, 6402-1, 6402-1 S, 6408-1

8816 P/5 042227

Repair Set for ratchet wheel 10 = 3/8" ■
 consisting of: ratchet wheel, pawl, shift lever, screws, ball, compression spring
 for 8816 G, 8816 GK, 8816 P, 8816 ST, 6110 CT, 6110-1 CT, 6111-1 CT, 6114-1 CT, 6115-1 CT, 6402-1

8816 P/7 N 042234

Repair Set for shift lever
 consisting of: shift lever, screws, ball, compression spring, spring washer, lockring
 for 5121-2 CLT, 5121-2 CT, 5122-2 CLT, 5122-2 CT, 5122 ST-1 5123-2 CLT, 5123-2 CT, 6121-1 CT, 6121 CT, 6122-1 CT, 6122 CT, 6123-1 CT, 6123 CT, 6127-1 CT, 6128-1 CT, 6291-2 CT

6122/7 025329

Repair Set for ratchet wheel 12.5 = 1/2" ■
 consisting of: ratchet wheel, pawl, shift lever, screws, ball, compression spring, spring washer, lockring
 for 5121-2 CLT, 5121-2 CT, 5122-2 CLT, 5122-2 CT, 5122 ST-1 5123-2 CLT, 5123-2 CT, 6121 CT, 6121-1 CT, 6122-1 CT, 6122 CT, 6123-1 CT, 6123 CT, 6127-1 CT, 6128-1 CT, 6722 TAC

6122/9 N 025343

Repair Set for shift lever
 consisting of: shift lever, screws, ball, compression spring
 for 1016, 1016/2, 6132-1 CT, 6143 CT, 6143-1 CT, 6144 CT, 6144-1 CT, 6145 CT, 6145-1 CT, 6146-1 CT

1016/6 001972

Repair Set for ratchet wheel 20 = 3/4" ■
 consisting of: ratchet wheel, pawl, shift lever, screws, ball, compression spring
 for 1016, 1016/2, 6132-1 CT, 6143 CT, 6143-01, 6143-1 CT, 6144 CT, 6144-01, 6144-1 CT, 6145 CT, 6145-01, 6145-1 CT, 6146-1 CT

1016/8 N 001989

Repair Set for twist lock
 consisting of: lock spring, twist lock with 2 headless screws
 for 6010-1 CT, 6110-1 CT, 6290-1 CT

6110-27 025053

Repair Set for twist lock
 consisting of: lock spring, twist lock with 2 headless screws
 for 5121-2 CLT, 5122-2 CLT, 5123-2 CLT 6021-1 CT, 6022-1 CT, 6023-1 CT, 6111-1 CT, 6115-1 CT, 6121-1 CT, 6122-1 CT, 6123-1 CT, 6127-1 CT, 6128-1 CT, 6291-1 CT, 6291-2 CT 6292-1 CT, 6293-1 CT, 6722 TAC, 6792 TAC

6122-27 025299

Repair Set for twist lock
 consisting of: twist lock, lock spring and cylinder screw
 for 6132-1 CT, 6143-1 CT, 6144-1 CT, 6145-1 CT, 6243-1 CT, 6244-1 CT, 6245-1 CT, 6246-1 CT, 6294-1 CT, 6295-1 CT, 6296-1 CT

6144-01/3 025527

Repair Sets for Torque Wrenches

Repair Set for optical signal transmitter
 consisting of: red button, compression spring, black housing, pin, screw
 for 6021-1 CT, 6022-1 CT, 6023-1 CT, 6110 CT, 6110-1 CT, 6111-1 CT, 6114-1 CT, 6115-1 CT, 6121 CT, 6121-1 CT, 6122 CT, 6122-1 CT, 6123 CT, 6123-1 CT, 6127-1 CT, 6128-1 CT, 6191-2 CT, 6290-1 CT, 6291-1 CT, 6292-1 CT, 6293-1 CT

6122-29 025305

Reversible ratchet with screw, complete (exchangeable): 20 = 3/4" ■
 until end of 2004
 for 6132-1 CT, 6143 CT, 6143-1 CT, 6144 CT, 6144-1 CT, 6145 CT, 6145-1 CT, 6146-1 CT

6143-01 111190

Reversible ratchet with pin, complete (exchangeable): 20 = 3/4" ■
 since 2005
 for 6132-1 CT, 6144 CT, 6144-1 CT, 6145 CT, 6145-1 CT, 6146-1 CT

6145-01 111206

Torque insert lock with screw
 for 6243-1 CT, 6244-1 CT, 6245-1 CT, 6294-1 CT, 6295-1 CT until end of 2004, 6296-1 CT until end of 2004

6294-01 026180

Torque insert lock with pin
 since 2005
 for 6295-1 CT, 6296-1 CT

6296-01 111213

Torque Tool Assortments



ⓔ

29 parts, in sheet metal box with plastic insert

- contents:
- | | |
|-----------|-------------------|
| 6290-1 CT | 6402-1 |
| 6450 c- | 7 8 9 10 11 12 |
| | 13 14 15 16 17 |
| 6612 c- | 10 11 12 13 14 17 |
| 6630 c- | 7 8 10 11 12 13 |
| | 14 15 16 17 |

HAZET No. EAN-No. 4000896+

6290-1 CT/29 026067



ⓔ

20 parts, in sheet metal box with plastic insert

- contents:
- | | |
|-----------|----------------|
| 6292-1 CT | 6404-1 |
| 6450 d- | 13 14 15 16 17 |
| | 18 19 21 22 |
| 6630 d- | 13 14 15 16 17 |
| | 18 19 21 22 |

HAZET No. EAN-No. 4000896+

6292-1 CT/20 026159

Torque Tool Assortments



578 x 235 x 88

28 parts, in sheet metal box with plastic insert

contents:

6292-1 CT 6404-1

6450 d-13 14 15 16 17 18 19

21 22 24 27 30 32

6630 d-13 14 15 16 17 18 19

21 22 24 27 30 32

HAZET No.	EAN-No. 4000896+
6292-1 CT/28	026166

Dynamometric Screwdriver



- Suitable in particular for the application in series production
- With inside hexagon drive 6.3 = 1/4" for screwdriver bits
- Release accuracy tolerance in direction of actuation ± 5%
- Tightening at torque setting is possible to the right only
- Without adjustment scale
- DIN EN ISO 6789

Adjusting of the desired torque value with enclosed Hex Head Wrench HAZET 2100 A-3/16 in conjunction with the Hydraulic Torque Tester HAZET 6903 or 6905

HAZET No.	Nm	l mm	EAN-No. 4000896+
6303	1-10	160	026678

Torque Wrenches



- **With lockable torque setting**
- Suitable in particular for application in series production
- With plug-and-socket connection to accommodate insert tools
- Release accuracy tolerance in direction of actuation ± 2%
- DIN EN ISO 6789

Adjusting the desired torque value with Adjustment Wrench HAZET 6399 in conjunction with Hydraulic Torque Tester HAZET 6903, 6905 or any other suitable Tester.

All Torque Wrenches of this line (HAZET 6391-6392) are without scale and without signal transmitter.

HAZET No.	□ mm	Nm	l mm	EAN-No. 4000896+
6391-12	9 x 12	2-12	125	027026
6391-25	9 x 12	2-25	180	027040
6391-35	9 x 12	15-35	180	027057



HAZET No.	□ mm	Nm	l mm	EAN-No. 4000896+
6391-50	9 x 12	5-50	240	027064
6391-85	9 x 12	15-85	315	027071

Torque Wrenches

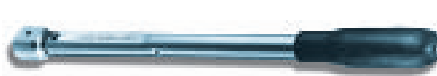

HAZET No.	□ mm	Nm	l mm	EAN-No. 4000896+
6392-200	14 x 18	50-200	400	027118
6392-320	14 x 18	60-320	630	027125

Special Levers



- Forged from solid steel
- **With plug-and-socket connection** to accommodate insert tools
- For loosening tight screwed connections
- **Without any torque functioning**

HAZET No.	□ mm	l mm	EAN-No. 4000896+
6396	9 x 12	405	027132
6397	14 x 18	635	027149

Adjustment Wrench



for Torque Wrenches HAZET 6391-6392, to adjust and to lock the torque value

HAZET No.	l mm	EAN-No. 4000896+
6399	167	027170

Please note...

... that the gauge dimension of the extended insert tool is very important for adjusting Torque Wrenches (see table and formula on page 151)

Insert Reversible Ratchets



- Square drive according to DIN 3120 A, ISO 1174-1 A
- 6401-1 20 teeth
- 6402-1 30 teeth
- 6403-1 32 teeth
- 6404-1 32 teeth
- Chrome-Vanadium
- Drop-forged
- Surface chrome-plated

HAZET No.	■ mm	l* mm	l mm	EAN-No. 4000896+	
6401-1	6,3 = 1/4"	9 x 12	19,5	46,5	027439
6402-1	10 = 3/8"	9 x 12	30,0	61,0	027460
6403-1	12,5 = 1/2"	9 x 12	38,5	74,5	027521
6404-1	12,5 = 1/2"	14 x 18	38,5	83,5	027552

Insert Reversible Ratchets



(E)

- Fine-tooth, **72 teeth**, rotation angle 5°
- Square drive according to DIN 3120 A, ISO 1174-1 A
- Chrome-Vanadium
- Drop-forged
- Surface chrome-plated

HAZET No.	■	■	l_w^* mm	l mm	EAN-No. 4000896+
6402	10 = 3/8"	9 x 12	26	58,5	027453
6403	12,5 = 1/2"	9 x 12	26	58,5	027514
6404	12,5 = 1/2"	14 x 18	27	70,5	027545
6406	20 = 3/4"	14 x 18	44	101,0	027576



(E)

- With locking device and quick release press-button
- Square drive according to DIN 3120 A, ISO 1174-1 A
- 6401-1S 20 teeth
- 6402-1S 30 teeth
- 6403-1S 32 teeth
- 6404-1S 32 teeth
- Chrome-Vanadium
- Drop-forged
- Surface chrome-plated

HAZET No.	■	■	l_w^* mm	l mm	EAN-No. 4000896+
6401-1S	6,3 = 1/4"	9 x 12	19,5	21,8	027446
6402-1S	10 = 3/8"	9 x 12	30,0	61,0	027477
6403-1S	12,5 = 1/2"	9 x 12	38,5	74,5	027538
6404-1S	12,5 = 1/2"	14 x 18	38,5	83,5	027569

Reversible Ratchets for Bits



(E) (O)

- For Screwdriver Bits
- Chrome-Vanadium
- Drop-forged
- Surface chrome-plated

HAZET No.	○	■	l_w^* mm	l mm	EAN-No. 4000896+
○ drive 6.3 = 1/4"					
20 teeth					
6408	6,3 = 1/4"	9 x 12	19,5	46,5	027583
○ drive 8 = 5/16"					
30 teeth					
6408-1	8 = 5/16"	9 x 12	30	61	027590

Spare Parts for Insert Reversible Ratchets

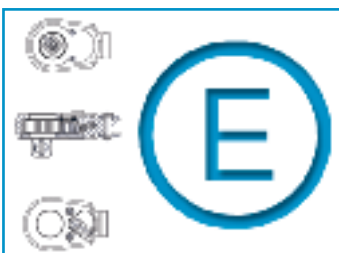

Spare Parts for Insert Reversible Ratchets

HAZET No. EAN-No. 4000896+

Repair Set for shift lever

consisting of: shift lever, screws, ball, compression spring for 8816 G, 8816 GK, 8816 P, 8816 S, 8816 ST 2264-1, 6110 CT, 6110-1 CT, 6111-1 CT, 6114-1 CT, 6115-1 CT 6402-1, 6402-1 S, 6408-1

8816 P/5 042227

Repair Set for ratchet wheel 10 = 3/8" ■

consisting of: ratchet wheel, pawl, shift lever, screws, ball, compression spring for 8816 G, 8816 GK, 8816 P, 8816 ST, 6110 CT, 6110-1 CT, 6111-1 CT, 6114-1 CT, 6115-1 CT, 6402-1

8816 P/7 N 042234

Repair Set for ratchet wheel 10 = 3/8" ■

consisting of: ratchet wheel, pawl, shift lever, screws, ball, compression spring for 8816 S, 6402-1 S

8816 S/7 048465

Repair Set for ratchet wheel 6.3 = 1/4" ○

consisting of: ratchet wheel, pawl, shift lever, screws, ball, compression spring for 2264-1, 6408-1

2264-1/7 015900

Repair Set for shift lever

consisting of: shift lever, screws, ball, compression spring for 6108-1 CT, 6109-1 CT, 6109-2 CT, 6401-1, 6401-1 S, 6408

6401-1/5 111176

Repair Set for ratchet wheel 6.3 = 1/4" ■

consisting of: ratchet wheel, pawl, shift lever, screws, ball, compression spring for 6108-1 CT, 6109-1 CT, 6109-2 CT, 6401-1

6401/7 111169

Repair Set for ratchet wheel 6.3 = 1/4" ■

consisting of: ratchet wheel, pawl, shift lever, screws, ball, compression spring for 6401-1 S

6401-1 S/7 111152

Repair Set for shift lever

consisting of: shift lever, screws, ball, compression spring, spring washer, locking for 6403-1, 6403-1 S, 6404-1, 6404-1 S

6403-1/7 070756

Repair Set for ratchet wheel 12.5 = 1/2" ■

consisting of: ratchet wheel, pawl, shift lever, screws, ball, compression spring, spring washer, locking for 6403-1, 6404-1

6403-1/9 070749

Repair Set for ratchet wheel 12.5 = 1/2" ■

consisting of: ratchet wheel, pawl, shift lever, screws, ball, compression spring, spring washer, locking for 6403-1 S, 6404-1 S

6403-1 S/9 070817

Repair Set for ratchet wheel 6.3 = 1/4" ○

consisting of: ratchet wheel, pawl, shift lever, screws, ball, compression spring for 6408

6408/7 111145

Insert Holder with Square Drives



Set, 4 parts

contents:
6413-1 2 3 4

HAZET No. EAN-No. 4000896+

6413/4 027651

Spare Parts

HAZET No.	■	■ mm	l* mm	l mm	EAN-No. 4000896+
Holder square insert 9 x 12 □ drive 10 = 3/8"					
6413-1	-	9 x 12	17,5	43,5	027644
Square drives ■ 10 = 3/8"					
6413-2	6,3 = 1/4"	-	-	22,0	048908
6413-3	10 = 3/8"	-	-	26,0	048892
6413-4	12,5 = 1/2"	-	-	30,4	048885

Insert Square Drives



- Square drive, DIN 3120 A, ISO 1174-1
- Chrome-Vanadium
- Surface chrome-plated

HAZET No.	■	■ mm	l* mm	l mm	EAN-No. 4000896+
6414	12,5 = 1/2"	14 x 18	25	63,5	027668
6416	20 = 3/4"	14 x 18	25	70,0	027682

Bit Holder



DIN 3126, chrome-plated

HAZET No.	○	■ mm	l* mm	l mm	EAN-No. 4000896+
6420 b	6,3 = 1/4"	9 x 12	17,5	40,5	027903
6420 c	8 = 5/16"	9 x 12	17,5	41,5	027910
6420 d	8 = 5/16"	14 x 18	25,0	58,0	027927

Insert Adapters



chrome-plated

HAZET No.	□ mm	■ mm	l* mm	l mm	EAN-No. 4000896+
square insert 14 x 18 to 9 x 12					
6423 c	14 x 18	9 x 12	34	50	027934
square insert 9 x 12 to 14 x 18					
6423 d	9 x 12	14 x 18	20	45	057559

Insert Adapter with Universal Joint



- For the operation of screwed connections in areas with restricted access or behind obstacles – e.g. with Torque Wrenches or Reversible Ratchets.
- May be used as extension and adapter 14 x 18 to 9 x 12
- Operation with □ 10 = 3/8" possible
- Flat style
- Chrome-Vanadium
- Chrome-plated
- DBGM – German registered utility model

Note: Tightening with precise torque values is possible only in straight, in-line position

HAZET No.	□ mm	■ mm	l* mm	l mm	EAN-No. 4000896+
6423 g	9 x 12	14 x 18	46	68	096053

Insert Adapters



- With plug-and-socket-connection to accommodate insert tools
- □ drive 10 = 3/8"
- For the operation of screwed connections in areas with restricted access (engine compartment)
- Chrome-Vanadium
- Surface chrome-plated

HAZET No.	■ mm	l* mm	l mm	EAN-No. 4000896+
6424 c	9 x 12	26,5	33,5	053759



for Torque Wrenches with plug-and-socket-connection 9 x 12 mm and insert tools (products with lateral insert dovetail guide)

HAZET No.	■ mm	■ mm	l* mm	l mm	EAN-No. 4000896+
6425 c	9,6 x 26	9 x 12	21	37	027941

Blank-End Inserts



HAZET No.	■ mm	l* mm	l mm	EAN-No. 4000896+
6430 c	9 x 12	**	25	027958
6430 d	14 x 18	**	38	027965

** = Note: Welding on tools with a gauge dimension > 45 mm will affect the release values

Open End Insert Tools



chrome-plated

HAZET No.	mm	l* mm	l mm	EAN-No. 4000896+
6450 c- 7	9 x 12	17,5	36,5	028429
6450 c- 8	9 x 12	17,5	37,0	028436
6450 c- 9	9 x 12	17,5	37,5	028443
6450 c-10	9 x 12	17,5	38,0	028320
6450 c-11	9 x 12	17,5	38,5	028337
6450 c-12	9 x 12	17,5	38,5	028344
6450 c-13	9 x 12	17,5	39,0	028351
6450 c-14	9 x 12	20,0	42,0	028368
6450 c-15	9 x 12	20,0	42,5	028375
6450 c-16	9 x 12	20,0	43,0	028382
6450 c-17	9 x 12	20,0	43,5	028399
6450 c-18	9 x 12	20,0	44,0	028405
6450 c-19	9 x 12	20,0	45,0	028412
6450 d-13	14 x 18	25,0	56,5	028450
6450 d-14	14 x 18	25,0	57,0	028467
6450 d-15	14 x 18	25,0	57,5	028474
6450 d-16	14 x 18	25,0	58,0	028481
6450 d-17	14 x 18	25,0	58,5	028498
6450 d-18	14 x 18	25,0	59,0	028504
6450 d-19	14 x 18	25,0	59,5	028511
6450 d-21	14 x 18	25,0	60,5	028528
6450 d-22	14 x 18	25,0	61,0	028535
6450 d-24	14 x 18	25,0	62,0	028542
6450 d-27	14 x 18	32,5	68,5	028559
6450 d-30	14 x 18	32,5	70,0	028566
6450 d-32	14 x 18	32,5	71,5	028573
6450 d-34	14 x 18	32,5	73,2	050178
6450 d-36	14 x 18	32,5	73,3	072507
6450 d-38	14 x 18	32,5	72,7	072514
6450 d-41	14 x 18	40,0	79,0	028580

TORX® Box-End Insert Tools



for outside TORX® screws

HAZET No.	mm	mm	l* mm	l mm	EAN-No. 4000896+
6609 c-E 8	9 x 12	7,52	17,5	39,0	074716
6609 c-E 10	9 x 12	9,42	17,5	40,0	049738
6609 c-E 11	9 x 12	10,08	17,5	40,6	049745
6609 c-E 12	9 x 12	11,17	17,5	42,1	049752
6609 c-E 14	9 x 12	12,90	17,5	42,8	049769
6609 c-E 16	9 x 12	14,76	17,5	44,3	049776
6609 c-E 18	9 x 12	16,70	17,5	45,0	049783
6609 c-E 20	9 x 12	18,49	17,5	46,5	049790
6609 c-E 22	9 x 12	20,32	17,5	47,0	049806
6609 c-E 24	9 x 12	22,16	17,5	48,8	049813
6609 d-E 10	14 x 18	9,42	25,0	58,0	054794
6609 d-E 11	14 x 18	10,08	25,0	58,5	054800
6609 d-E 12	14 x 18	11,17	25,0	59,0	054817
6609 d-E 14	14 x 18	12,90	25,0	60,0	054824
6609 d-E 16	14 x 18	14,76	25,0	61,0	054831
6609 d-E 18	14 x 18	16,70	25,0	62,0	054848
6609 d-E 20	14 x 18	18,49	25,0	63,5	054855
6609 d-E 22	14 x 18	20,32	25,0	64,3	054862
6609 d-E 24	14 x 18	22,16	25,0	65,3	054879

Flare Nut Insert Tools



Flare Nut Insert Tools

chrome-plated

HAZET No.	mm	l* mm	l mm	EAN-No. 4000896+
6612 c-10	9 x 12	17,5	42,3	028726
6612 c-11	9 x 12	17,5	42,8	028733
6612 c-12	9 x 12	17,5	43,4	028740
6612 c-13	9 x 12	17,5	43,7	028757
6612 c-14	9 x 12	17,5	44,4	028764
6612 c-16	9 x 12	17,5	45,4	028771
6612 c-17	9 x 12	17,5	45,9	028788
6612 c-18	9 x 12	17,5	46,1	028795
6612 c-19	9 x 12	17,5	46,8	028801
6612 c-21	9 x 12	17,5	48,0	028818
6612 c-22	9 x 12	17,5	48,8	028825

Box-End Insert Tools



HAZET No.	mm	l* mm	l mm	EAN-No. 4000896+
6630 c-7	9 x 12	17,5	40,0	028955
6630 c-8	9 x 12	17,5	40,6	028962
6630 c-10	9 x 12	17,5	42,1	028832
6630 c-11	9 x 12	17,5	42,8	028849
6630 c-12	9 x 12	17,5	43,5	028856
6630 c-13	9 x 12	17,5	43,8	028863
6630 c-14	9 x 12	17,5	45,0	028870
6630 c-15	9 x 12	17,5	45,5	028887
6630 c-16	9 x 12	17,5	46,5	028894
6630 c-17	9 x 12	17,5	47,0	028900
6630 c-18	9 x 12	17,5	47,8	028917
6630 c-19	9 x 12	17,5	48,8	028924
6630 c-21	9 x 12	17,5	50,0	028931
6630 c-22	9 x 12	17,5	50,8	028948
6630 d-13	14 x 18	25,0	60,8	028979
6630 d-14	14 x 18	25,0	61,5	028986
6630 d-15	14 x 18	25,0	62,0	028993
6630 d-16	14 x 18	25,0	62,9	029006
6630 d-17	14 x 18	25,0	63,6	029013
6630 d-18	14 x 18	25,0	64,3	029020
6630 d-19	14 x 18	25,0	65,3	029037
6630 d-21	14 x 18	25,0	66,5	029044
6630 d-22	14 x 18	25,0	67,3	029051
6630 d-24	14 x 18	25,0	68,8	029068
6630 d-27	14 x 18	31,0	76,8	029075
6630 d-30	14 x 18	31,0	78,5	029082
6630 d-32	14 x 18	31,0	79,8	029099
6630 d-34	14 x 18	31,0	81,3	029105
6630 d-36	14 x 18	31,0	82,5	029112
6630 d-41	14 x 18	31,0	85,5	029129

Accessories



Safe Boxes, empty

plastic, black,
for safe keeping of Torque Wrenches

HAZET No.	l mm	EAN-No. 4000896+
for HAZET 5110-1 CT 6110-1 CT 6110 CT 6290-1 CT		
6060 BX-2	420	024629
for HAZET 5121-1 CT 6111-1 CT 6115-1 CT 6121-1 CT 6121 CT 6291-1 CT 6291-2 CT		
6060 BX-4	530	024636
for HAZET 5122-1 CT 6122-1 CT 6122 CT 6127-1 CT 6292-1 CT		
6060 BX-6	635	024643

Mechanical Angle Dials



- For tightening screws as a function of the **torsion angle**
- To be used between Torque Wrenches with ■ drive 12.5 = 1/2" (resp. 20 = 3/4") and sockets with □ drive 12.5 = 1/2" (resp. 20 = 3/4")
- With flexible magnetic holder for the fixing point
- Range 0–360°, Graduation 1°, 95 mm ø

HAZET No.	□ ■	EAN-No. 4000896+
6690	12,5 = 1/2"	029266
6690-1	20 = 3/4"	029273

Torque Multipliers



- For tightening and loosening **tight screwed connections**
- Avoids the application of impact tools, extensions, lever arms, etc.
- No external power source necessary, low-maintenance
- High accuracy ± 5%
- For building and agricultural machines, trucks, plant and engine construction and shipbuilding

torque ratio:

6800-700	1:3.5
6800-1400	1:3.5
6800 Lg-1400	1:3.5
6800-2800	1:12

HAZET No.	Nm	□	■	EAN-No. 4000896+
6800-700	700	12,5 = 1/2"	20 = 3/4"	062775
6800-1400	1400	20 = 3/4"	25 = 1"	062744
6800-2800	2800	20 = 3/4"	25 = 1"	062768

extra long style

e.g. for deeply located screwed connections on commercial vehicles

6800 Lg-1400	1400	20 = 3/4"	25 = 1"	062751
--------------	------	-----------	---------	--------

Hydraulic Torque Testers



- For torque wrench testing and adjustment
- Tolerance ± 1% of scale value
- Low mass acceleration
- Reduced friction
- Ball-bearing primary shaft
- Motion of pointer damped, pointer does not swivel or move upon release of the Torque Wrench
- Inside 8-point drive 12.5 = 1/2" additional adapter 10 = 3/8" and 20 = 3/4" (included)
- Space-saving wall fixation with two heavy-duty dowels (included)

HAZET No.	Nm	EAN-No. 4000896+
6903	10-200	029310
6905	20-400	029327

...the right torque is all that matters!



The new HAZET Torque Multipliers 6800

For tightening and loosening tight screwed connections and for screwed connections with high torque value

- Avoids the application of lever arms, impact tools, etc. – saves screwed connections
- No external power source necessary, low maintenance, high accuracy ±5%
- Application e.g. for building and agricultural machines, trucks, busses, plant and engine construction and shipbuilding



Electronic Torque Tester



- Enables testing Display Torque Wrenches as well as Click-Type Torque Wrenches
- For the **peak value indication** or **click point recognition**
- With function keys for the selection of the measuring units "Nm" and "lbf. ft
- Display either in German or English
- Measuring range 10 Nm up to 500 Nm, accuracy tolerance $\pm 1\%$
- Additional torque testing sensors are available for values ≤ 10 Nm and ≥ 500 Nm
- With interface for the transmission of data records after each measurement
- Display with digital bar chart for the indication of the introduced torque value in proportion to the test value
- With sockets for the connection of
 - drive 6.3 = 1/4"
 - 10 = 3/8" - 12.5 = 1/2" - 20 = 3/4"
- Suitable for wall or table fixation

HAZET
No.

EAN-No.
4000896+

7900 E

072095

Torque Wrenches and Torque Testers are high precision measuring tools. They have to be checked with an appropriate Tester after a certain period of time and adjusted when required. The checking frequency depends on the using frequency.

HAZET disposes of the corresponding Torque Testers. After testing and adjustment, the Torque Wrenches and Torque Testers sent to HAZET are supplied with a Test Certificate.

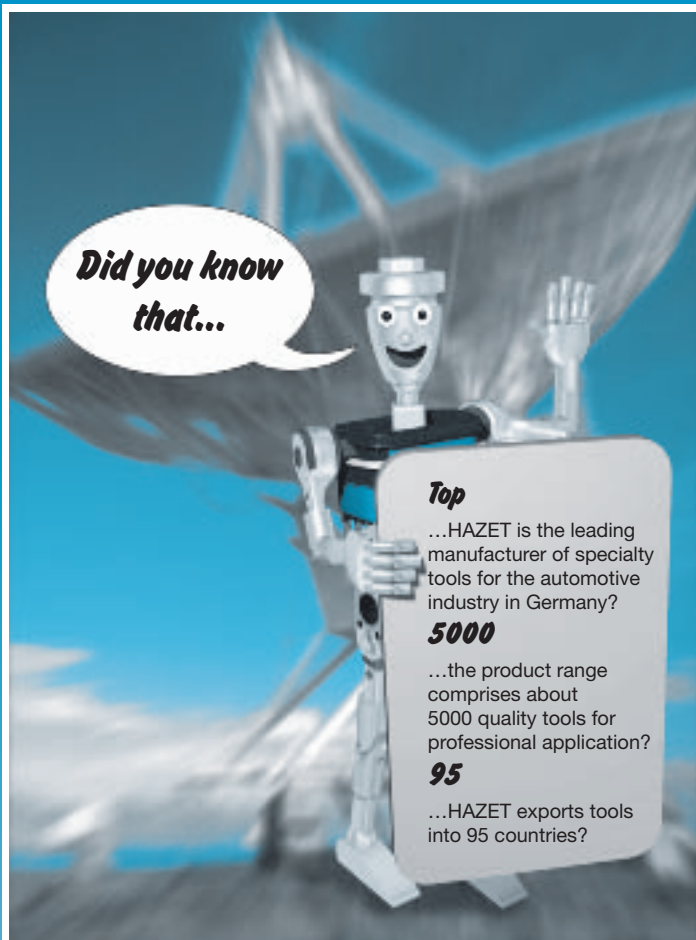

Did you know that...

Top

...HAZET is the leading manufacturer of specialty tools for the automotive industry in Germany?

5000

...the product range comprises about 5000 quality tools for professional application?

95

...HAZET exports tools into 95 countries?

The HAZET Torque Testing Devices are constantly supervised and calibrated by the accredit Calibration Laboratory SCHATZ, German Calibration Service (DKD). This guarantees the existing essential competence in the field of controlled screw tightening as well as the high quality of the HAZET Torque Wrenches and Torque Testing Devices.

HAZET Conversion Chart · Torque Values

SYSTEM 5000 CT/6000 CT

lbf.ft	Nm	lbf.ft	Nm
1	1.4	35	47.5
2	2.7	40	54.2
3	4.1	45	61.0
4	5.4	50	67.8
5	6.8	60	81.3
6	8.1	70	94.9
7	9.5	80	108.5
8	10.8	90	122.0
9	12.2	100	135.6
10	13.6	120	162.7
15	20.3	140	189.8
20	27.1	160	216.9
25	33.9	180	244.0
30	40.7	200	271.2

Nm	lbf.ft	Nm	lbf.ft
1	0.7	40	29.5
2	1.5	45	33.2
3	2.2	50	36.9
4	3.0	55	40.6
5	3.7	60	44.3
6	4.4	70	51.6
7	5.2	80	59.0
8	5.9	90	66.4
9	6.6	100	73.8
10	7.4	110	81.1
15	11.1	120	88.5
20	14.8	130	95.9
25	18.4	140	103.3
30	22.1	150	110.6
35	25.8	200	147.5

1 Nm \triangleq 0.7376 lbf.ft

1 lbf.ft \triangleq 12 lbf.in

1 Nm \triangleq 0.1020 kpm

1 lbf.ft \triangleq 1.3558 Nm

1 lbf.in \triangleq 0.0833 lbf.ft

1 kpm \triangleq 9.807 Nm

Note:

During continuous operation with Reversible Ratchets and square drive Insert Tools (HAZET 6401-1 - 6416) the max. torque values are limited as follows.: 6401-1 = 40 Nm, 6402, 6402-1 = 120 Nm, 6403, 6403-1 = 120 Nm, 6404, 6404-1 = 300 Nm, 6406 = 800 Nm. The max. torque values of Open End-, Flare Nut- and Box Wrenches (HAZET 6450 - 6630) depend on

respective wrench size (DIN 899) and can be smaller than the max. torque value of the tool in operation. The audible and palpable "click"-signal abates when torque value is lower.

The release accuracy corresponds to a room temperature of 20 °C.

Torque Wrench to be reset to smallest value after operation!

Impact Wrenches



- **Ultra-light magnesium housing**
lighter than comparable aluminium housings
- Powerful pin clutch mechanism
- 3 power settings in forward
- Cold insulated handle
- Exhaust air is guided through the handle downwards
- Low in vibration
- Forward and reverse
- Easy handling

HAZET No.	Nm max.	rpm max.	EAN-No. 4000896+
9011 MG	250	10000	109180



- **Ultra-light magnesium housing**
lighter than comparable aluminium housings
- Powerful twin hammer mechanism
- 3 power settings in forward
- Cold insulated handle
- Exhaust air is guided through the handle downwards
- Low in vibration
- Forward and reverse
- Easy handling

HAZET No.	Nm max.	rpm max.	EAN-No. 4000896+
9012 MG	740	7000	109197



- **Ultra-light magnesium housing**
lighter than comparable aluminium housings
- Powerful twin hammer mechanism
- 3 power settings in forward
- Cold insulated handle
- Exhaust air is guided through the handle downwards
- Low in vibration
- Forward and reverse
- Easy handling

HAZET No.	Nm max.	rpm max.	EAN-No. 4000896+
9013 MG	1490	5500	109210

Impact Wrenches



- **Ultra-light magnesium housing**
lighter than comparable aluminium housings
- Powerful twin hammer mechanism
- Multiple power settings in forward and reverse
- Cold insulated handle
- Exhaust air is guided downwards

HAZET No.	Nm max.	rpm max.	EAN-No. 4000896+
9014 MG	2160	4500	109227
9014 MG-LG	2160	4500	115853



- **Esp. for wheel mounting**
- For controlled screw tightening **without impact effect with max. 50 Nm**
- Loosening of screws at max. 700 Nm with automatic impact system
- Overload protection due to pressure control at 6.3 bar
- Low vibration
- Exhaust air is guided through the handle
- drive 12.5 = 1/2", in conjunction with Impact Sockets e.g. HAZET 900 S
- noise level 85.1 dB (A)
- air consumption 300 l/min

HAZET No.	Nm max.	rpm max.	EAN-No. 4000896+
9012-50	700	7000	083732



- **Maximum performance at minimum weight**
- Shock resistant plastic housing
- Powerful twin hammer mechanism
- Multiple power settings in forward and reverse
- Low-vibration and cold insulated handle
- Exhaust air is guided through the handle downwards

HAZET No.	Nm max.	rpm max.	EAN-No. 4000896+
9012 KS	690	7700	109203

Air Ratchets



- Forward and reverse
- Infinite power regulator
- Cold insulated handle
- Low in vibration

HAZET No.	Nm max.	rpm max.	EAN-No. 4000896+
9020-2	35	170	109423



- Forward and reverse
- Infinite power regulator
- Cold insulated handle
- Low in vibration

HAZET No.	Nm max.	rpm max.	EAN-No. 4000896+
9021-2	70	160	109449



- Forward and reverse
- Infinite power regulator
- Cold insulated handle
- Low in vibration

HAZET No.	Nm max.	rpm max.	EAN-No. 4000896+
9022-2	70	160	109946

Air Drill



- Quick-change chuck, capacity 1-10 mm
- Forward and reverse
- Speed regulation with push-button
- Cold insulated handle
- Exhaust air is guided through the handle downwards
- Robust housing
- Suitable for continuous operation
- **Especially appropriate for car body works and industry**

HAZET No.	EAN-No. 4000896+
9030-1	109470

Chisel Hammer Set



- For detaching auto body sheets with compressed air
- 3000 impacts/min
- Chisel insert: \varnothing 10 mm
- Power control with push-button
- Cold insulated handle
- Set with 5 chisels (length: 175 mm each)

HAZET No.	EAN-No. 4000896+
9035/6	109463

Air Blow Guns

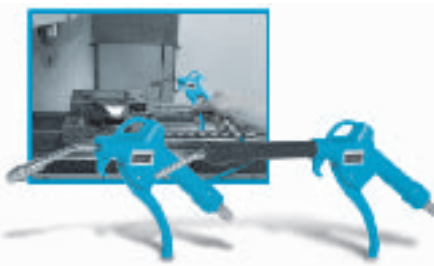

- For the fast removing and cleaning of chips and other kinds of foreign substances
- With non-slip handle
- Body material: nylon, nozzle material: steel
- Max. pressure: 220 PSI / 15 bar
- Working pressure: 75 up to 120 PSI, 5 up to 8 bar
- Air inlet thread: 6.3 mm (1/4")

HAZET No.	EAN-No. 4000896+
9040-1	109487
Nozzle length continuously adjustable from 165 to 280 mm	
9040-2	109494

Pocket Blow Pen



- Practical and compact design with clip for fixation in pockets
- Turn to adjust air flow, air nozzle- \varnothing 3 mm
- Easy handling, clicks directly on air coupling 7.2 mm
- High-quality Perbunan seal (NBR)
- Duraluminium housing

HAZET No.	EAN-No. 4000896+
9040-3	109500

SPARE PARTS ⑤	HAZET No.	EAN-No. 4000896+	SPARE PARTS ⑤	HAZET No.	EAN-No. 4000896+
for Tool Cabinet 111			Indexing box for table board, complete	160-20	004348
Padlock with 2 keys	160-08a	004294	Top intermediary tray, complete with indexing box	160-30	004355
for Tool Trolley 162 C			Indexing box for top intermediary tray, complete	160-40	004362
Container for small parts for 162 C and 166 C	162 C-5	078189	Bottom intermediary tray, complete	160-50	004379
Separation sheet for intermediary tray for 162 C and 166 C	162 C-6	079810	Bottom container	160-60	004393
Fixed castor \varnothing 150 mm complete	162 C-09	079872	Pillar with plastic knob	160-70	004409
Table board complete with worktop	162 C-010	079780	Chain, 31 links, per pair	160 Lg-01	004447
Swivel castor \varnothing 125 mm complete with brake	162 C-011	079865	for Tool Cabinet 166 N		
Castor Set , consisting of: 2 swivel castors \varnothing 125 mm and set of fixed castors \varnothing 150 mm	162 C-0119	079889	Padlock with 2 keys	160-08 a	004294
Top intermediary tray	162 C-030	078165	Fixed castor, 125 mm \varnothing , complete	160-09	004300
Bottom intermediary tray	162 C-050	078172	Swivel twin castor, 75 mm \varnothing , with brake, complete (to be used in pairs)	160-011	004225
Bottom Container	162 C-060	079728	Rubber mat for table board	160-012	004263
Pillar with knob	162 C-070	079742	Profiled rubber strip with black filler for table board and intermediary trays	160-013	004270
Knob	162 C-080	080397	Cross member for fixed castors	160-044	004287
Chain with locking of chain case	162 C-01/2	079735	Castor Set consisting of: 2 fixed castors, 125 mm \varnothing , complete, 2 double swivel castors, 75 mm \varnothing , with brake, complete	160-0119	004232
for Tool Trolley 166 C			Profiled metal strips	160-1	004317
Container for small parts for 162 C and 166 C	162 C-5	078189	Separation sheet, 323 mm long, for intermediary trays	160-6	004386
Separation sheet for intermediary tray for 162 C and 166 C	162 C-6	079810	Table board, complete with indexing box and chain	160-10	004324
Fixed castor \varnothing 150 mm complete	162 C-09	079872	Indexing box for bottom intermediary tray	160-15	004331
Table board complete with worktop	162 C-010	079780	Indexing box for table board, complete	160-20	004348
Swivel castor \varnothing 125 mm complete with brake	162 C-011	079865	Top intermediary tray, complete with indexing box	160-30	004355
Castor Set , consisting of: 2 swivel castors \varnothing 125 mm and set of fixed castors \varnothing 150 mm	162 C-0119	079889	Indexing box for top intermediary tray, complete	160-40	004362
Top intermediary tray	162 C-030	078165	Bottom intermediary tray, complete	160-50	004379
Bottom intermediary tray	162 C-050	078172	Bottom container	160-60	004393
Bottom Container	162 C-060	079728	Pillar complete with clamping rod and knob	160-71	004416
Chain with locking of chain case	162 C-01/2	079735	Clamping rod with handle, complete	160-90	004430
Pillar complete with knob and clamping rod	166 C-070	079759	Chain, 31 links, per pair	160 Lg-01	004447
Knob	166 C-080	080403	for Tool Trolley 168		
for Tool Cabinet 162 N			Ball bearing rails for 152 N 168 169 HD 174 up to 2000, rails riveted, carrier of drawer 545 mm complete, per pair	152 N-07	003501
Padlock with 2 keys	160-08 a	004294	Fixed castor, 125 mm \varnothing , complete	160-09	004300
Fixed castor, 125 mm \varnothing , complete	160-09	004300	Swivel twin castor, 75 mm \varnothing , with brake, complete (to be used in pairs)	160-011	004225
Swivel twin castor, 75 mm \varnothing , with brake, complete (to be used in pairs)	160-011	004225	Castor Set consisting of: 2 fixed castors, 125 mm \varnothing , complete, 2 double swivel castors, 75 mm \varnothing , with brake, complete	160-0119	004232
Rubber mat for table board	160-012	004263	Profiled metal strips	160-1	004317
Profiled rubber strip with black filler for table board and intermediary trays	160-013	004270	Separation sheet, 323 mm long, intermediary trays for	160-6	004386
Cross member for fixed castors	160-044	004287	Table board, complete with indexing box and chain	160-10	004324
Castor Set consisting of: 2 fixed castors, 125 mm \varnothing , complete, 2 double swivel castors, 75 mm \varnothing , with brake, complete	160-0119	004232	Indexing box for bottom intermediary tray	160-15	004331
Rubber mat for table board	168-012	005048			
Hand knob black, with inside hexagon screw	168-055	005062			
Pull-handle for 168 170-6 170 C-5 170 L	170-06	060214			

SPARE PARTS ⑤	HAZET No.	EAN-No. 4000896+	SPARE PARTS ⑤	HAZET No.	EAN-No. 4000896+
for Tool Trolley 169 HD			Plastic Worktop for 170-6 170 C-5 170 L	170-05	060238
Padlock, long with 2 keys	168-08 a	005086	Pull-handle for 168 170-6 170 C-5 170 L	170-06	060214
1 st , 2 nd , 3 rd or 4 th drawer 45 mm high, without separation sheets	169-03	005321	Pair of ball bearing rails for fixing the drawers in HAZET 170-6, 170K-5, 170 L	170-07	060245
Set of separation sheets, consisting of: 4 separation sheets 342 mm long	169-04	005338	Fixed castor, 125 mm ϕ for 170-6 170 C-5 170 L	170-09	060252
Ball bearing rails for 152 N 168 169 HD 174 up to 2000, rails riveted, carrier of drawer 545 mm complete, per pair	152 N-07	003501	for Tool Cabinet 171		
Fixed castor, 125 mm ϕ	169-09	005352	Padlock with 2 keys	160-08 a	004294
Swivel castor, 100 mm ϕ , with brake, with screw	169-011	005284	Fixed castor, 125 mm ϕ , complete	160-09	004300
Rubber mat for table board	169-012	005307	Swivel twin castor, 75 mm ϕ , with brake, complete (to be used in pairs)	160-011	004225
Cross member, suitable for right or left	154-044	003594	Castor Set consisting of: 2 fixed castors, 125 mm ϕ , complete, 2 double swivel castors, 75 mm ϕ , with brake, complete	160-0119	004232
Hand knob black, with inside hexagon screw	169-055	005345	Drawer for spare parts with ball beared safety rails	171-01	005406
for Tool Trolley 169 N			Rubber mat for table board	171-012	005413
Swivel castor with brake, 100 mm ϕ	169 N-011	059263	Plastic shutter, complete	171-031	005437
Swivel castor without brake, 100 mm ϕ	169 N-0110	059270	Plastic tray for drawer	171-1	005468
Castor set complete: 2 fixed castors, 2 swivel castors	169 N-0119	059294	ditto with ball beared safety rails, since 1992	171-04	005444
Flat drawer, 80 mm	169 N-02	090303	for Tool Cabinet 172 HD up to model year 12/1991 (with cylinder lock on lock strip)		
High drawer, 166 mm	169 N-03	090310	Cylinder lock, complete, with 4 keys	172-08 a	005697
Plastic worktop	169 N-05	060986	Lock cylinder only, with 4 keys and 2 screws	172-08 b	005703
Pull-handle	169 N-06	060979	Fixed castor, 160 mm ϕ , complete	172-09 +	005710
For 174 from 01/2001 to 05/2001 and 169 N until 04/2000 Ball bearing rails, riveted, carrier of drawer 565 mm complete, per pair	169 N-07	080359	Swivel castor, 125 mm ϕ , with brake, complete	172-011 +	005550
For 174 since 06/2001, 169 N since 05/2000 and 176-1 Ball bearing rail, suspended, carrier of drawer 565 mm and for the laterally extendable leaf of 173 complete, per pair	169 N-07/2	080304	Castor Set , consisting of: 2 fixed castors, 160 mm ϕ , with axle 20 mm ϕ , complete, 2 swivel castors, 125 mm ϕ , with adequate fastening and brake, complete	172-0119	005567
Fixed Castor 160 mm ϕ	169 N-09	059287	Rubber mat for table board	172-012	005574
for Tool Trolley 170			Plastic shutter, complete	172-030	005598
Swivel castor with brake, 125 mm ϕ for 170-6 170 C-5 170 L	170-011	060269	Top shutter	172-030 a	005604
Swivel castor without brake, 125 mm ϕ for 170-6 170 C-5 170 L	170-0110	060276	Bottom shutter	172-030 u	005611
Castor set for 170-6 170 C-5 170 L consisting of: 170-09 (2x) 170-010 170-011 1 axle ϕ 12 x 533 mm, locking ring RS 10	170-0119	060283	Lock cap	172-082	005680
Rubber mat for antislipping storage of tools etc. in Tool Trolleys particularly suitable for HAZET 170-6, 170 C-5, 170 K-4, 170 K-5, 170-2, 170 L	170-012	060221	Plastic tray for drawer	171-1	005468
			Drawer for spare parts with ball beared safety rails	171-01	005406
			Separation sheet, 395 mm long, for intermediary tray	172-5	005789
			+ = Attention: please consider ϕ when ordering wheels / castors		

SPARE PARTS ⑤	HAZET No.	EAN-No. 4000896+	SPARE PARTS ⑤	HAZET No.	EAN-No. 4000896+
since 1992 (combined lock and handle ridge made of metal, plastic coated, with padlock) Padlock, long with 2 keys	168-08 a	005086	for Tool Trolley 174 Ball bearing rails for 152 N 168 169 HD 174 up to 2000, rails riveted, carrier of drawer 545 mm complete, per pair	152 N-07	003501
Castor Set , consisting of: 2 fixed castors, 160 mm ϕ , with axle 20 mm ϕ , complete, 2 swivel castors, 125 mm ϕ , with adequate fastening and brake, complete	172-0119 +	005567	Flat drawer for Tool Trolley 174 until 12/2000	174-02	090358
Drawer for spare parts with ball beared safety rails	171-01	005406	High drawer for Tool Trolley 174 until 12/2000	174-03	090396
Fixed castor, 160 mm ϕ , complete	172-09 +	005710	Flat drawer for Tool Trolley 174 since 01/2001	174-04	090334
Swivel castor, 125 mm ϕ , with brake, complete	172-011 +	005550	High drawer for Tool Trolley 174 since 01/2001	174-05	090327
Rubber mat for table board	172-012	005574	Separation sheet, 345 mm long, transverse pitch – in drawers	174-015	005857
Plastic shutter, top and bottom, with combination lock and handle strip, complete	172-032	005642	Separation sheet, 520 mm long, longitudinal pitch in drawers	174-016	005864
Top shutter complete with combination lock and handle strip	172-032 a	005659	Fixed castor, 160 mm ϕ , complete	172-09	005710
Bottom shutter complete with combined lock and handle strip	172-032 u	005666	Swivel castor, 125 mm ϕ , with brake, complete	154-011	003563
Plastic tray for drawer	171-1	005468	Swivel castor, 125 mm ϕ , without brake	174-0110	005833
for Tool Cabinet 173 Plastic worktop	173-05	089796	Castor Set consisting of: 2 fixed castors, 160 mm ϕ , with axle 12 mm ϕ , 2 swivel castors, 125 mm ϕ , with brake, complete, 1 swivel castor without brake	174-0119	005840
Beech multilayer worktop, fixing kit included	173-06	089802	+ = Attention: please consider ϕ when ordering wheels / castors		
Pair of rails for front drawers, complete, per pair	173-07	089819		For 174 since 06/2001, 169 N since 05/2000 and 176-1 Ball bearing rail, suspended, carrier of drawer 565 mm and for the laterally extendable leaf of 173 complete, per pair	169 N-07/2
Pair of rails for side-locker, complete, per pair	173-08	089826	For 174 from 01/2001 to 05/2001 and 169 N until 04/2000 Ball bearing rails, riveted, carrier of drawer 565 mm complete, per pair	169 N-07	080359
For 174 since 06/2001, 169 N since 05/2000 and 176-1 Ball bearing rail, suspended, carrier of drawer 565 mm and for the laterally extendable leaf of 173 complete, per pair	169 N-07/2	080304	for Tool Trolley 176 Plastic worktop	176-05	099139
Fixed castor, screws included, 125 mm ϕ	173-09	089932	Flat drawer, without front cover	176-050	099177
Swivel castor, with brake, screws included	173-011	089949	Flat front cover, black	176-051	099146
Lock for side-locker and closing cylinder for central locking system	173-013	090174	High drawer, without front cover	176-060	099184
5 plastic pawls for central locking system	173-017	090181	High front cover, black	176-061/2	099153
5 drawer locking pins, screws included	173-019	090198	High front cover, yellow	176-062/2	099160
Flat drawer (70 mm high), complete, bolts, rivets, fixing device and instructions included	173-050	089956	For 174 since 06/2001, 169 N since 05/2000 and 176-1 Ball bearing rail, suspended, carrier of drawer 565 mm and for the laterally extendable leaf of 173 complete, per pair	169 N-07/2	080304
High drawer (140 mm high), complete, bolts, rivets, fixing device and instructions included	173-060	089963	Fixed castor, 100 mm ϕ , screws included	176-09	099214
Laterally extendable leaf, complete, cover plate, handle and screws included	173-070	090013	Swivel castor, 100 mm ϕ with brake, screws included	176-011	099191
Side-locker, complete, cover plate, handle and screws included	173-080	089970	Swivel castor, 100 mm ϕ without brake, screws included	176-012	099207
Pull-handle for 173, complete, handle support and screws included	173-090	090020	Lock, fixation accessories included	176-013	099221
Handle, small, for lateral leaf	173-091	090112	Pull-handle for 173 complete, handle support and screws included	173-090	090020
5 decorative strips for drawers	173-092	090129			
Edge protection strip for 173-2	173-093	090204			

SPARE PARTS ⑤	HAZET No.	EAN-No. 4000896+	SPARE PARTS ⑤	HAZET No.	EAN-No. 4000896+
for Tool Trolley 180					
Locking strip for central locking	180-04	110889	Pair of straight spare jaws for 792-1 ditto, curved, for 792-1	792-1 E a	031498
Plastic worktop	180-05	110773	ditto, straight, for 792-2	792-1 E b	031504
Pull handle	180-06	110766	ditto, curved, for 792-2	792-2 E a	031528
Guiding rails, per pair	180-07	110780		792-2 E b	031535
Cylinder lock with 2 hinged keys	180-08	110896	Wrench for 794-01	794-010	031603
Fixed castor, 125 mm ϕ	180-09	110759	ditto for 794-1, -2, -3	794-10	031627
Swivel castor with brake, 125 mm #ch10 ϕ	180-011	110742	Strap for 794 U-3	794 U-301	031689
Flat drawer, complete	180-050	110506	Guide member for 794 U-3	794 U-302	031696
Cover plate, complete, for flat drawer	180-051	110520	Segment with slip strap for 794 U-3	794 U-303	031702
High drawer, complete	180-060	110513	Wooden handle for 795	795-014	031733
Cover plate, complete, for big drawer	180-061	110735	Rubber pad for		
			795-1	795-01	031726
			795-2	795-02	031740
			795-3	795-03	031757
			795-4	795-04	031764
for various Tool Trolleys			Bowden cable for 798-15 A		
1 Rubber pad for 161-8, complete with screws, washer and seal	161-81	004850	complete with fixing kit, 2 x nuts M 4	798-0151 A	097753
Joint for 161-9	161-92	004874	Bowden cable for 798-15 A	798-0152 A	097760
			Sliding guide device for 798-15 A	798-0153 A	097784
1 Rubber pad for 161-9, with grooved pin, 2 dowel pins and 2 compression springs	161-95	004881	Sets consisting of:		
			2 retainer bolts, 2 lock washers for 798		
			798-1	798-0/4	031849
			798-3	798-01/4	031856
			798-4	798-03/6	107513
			798-5	798-04/4	031887
			798-6 798-12	798-05/4	031894
			798-10	798-012/4	031870
				798-010/4	031863
Various Spare Parts			Bowden cable complete with fixing kit, 2 x nuts M 4		
Sets , consisting of:			for 798-15	798-0151	082254
Roller, Pin and Spring for 279-4, 279 V-4	279-04/3	018017	Bowden cable for 798-15	798-0152	082247
for 279-6, 279 V-6	279-06/3	018024	Sliding guide device for 798-15	798-0153	082230
for 279-8, 279 V-8	279-08/3	018031			
for 279-10, 279 V-10	279-10/3	017973	Chisel and anvil (counterpart)		
for 279-12, 279 V-12	279-12/3	017980	for 846-22	846-103	035908
for 279-15	279-15/3	017997	ditto for 846-36	846-203	035915
for 279-18	279-18/3	018000			
Sets consisting of:			Spare chisel		
socket, screw and lock washer for			for 846-22	846-022	058006
645-6	645-06/3	027989	for 846-36	846-036	057993
645-7	645-07/3	027996			
645-8	645-08/3	028009	Spare chisel for 847-0410	847-04	057986
645-9	645-09/3	028016			
645-10, 602-10	645-10/3	028023	Chisel, small and large for 847-1027	847-10	035946
645-11, 602-11	645-11/3	028047	ditto for 847-1736	847-17	035960
645-12, 602-12	645-12/3	028054			
645-13, 602-13	645-13/3	028078	For Reversible Ratchets etc.		
645-14, 602-14	645-14/3	028085	Repair Set for ratchet wheel 6.3 = 1/4" ■	863 N/6	038541
645-15, 602-15	645-15/3	028108	consisting of: ratchet wheel		
645-16, 602-16	645-16/3	028115	with quick-release press-button,		
645-17, 602-17	645-17/3	028139	pawl, cap screws, 1 holding		
645-18, 602-18	645-18/3	028153	down bolt each (small and large), for 863 N		
645-19, 602-19	645-19/3	028177			
645-21, 602-21	645-21/3	028207	Repair Set for shift lever	863 P/5	038589
645-22, 602-22	645-22/3	028238	consisting of: shift lever, screws, ball,		
			compression spring		
			for 863, 863 G 863 P, 863 PC, 863 Q, 863 S,		
			863 ST, 2264		
Plastic part with screws for 650 K-20	650 K-020/6	028689	Repair Set for ratchet wheel 6.3 = 1/4" ■	863 P/7 N	038596
			consisting of: ratchet wheel, pawl, shift lever,		
Plastic Hammer Head for 665-1	665-01	029211	screws, ball, compression spring		
			for 863 G, 863 P, 863 PC		
Punch tip for 747	747-01	029877	Repair Set for ratchet wheel 6.3 = 1/4" ■	863 S/7	048472
			consisting of: ratchet wheel, pawl, shift lever,		
Punch tip for 747-1	747-02	051380	screws, ball, compression spring		
			for 863 Q, 863 S		
Set consisting of:			Plastic handle for 863 P, 863 PC, 864	863 KG-03	038510
screw, nut and lock washer for 760-1	760-1/3	030439			
			Joint connection for 863 G	863 G-013	038503
Sets consisting of:			Repair Set consisting of:		
fixable screw and lock washer for			hinged section, screw and lock washer		
760 N-1	760 N-1/2	030477	for 864	864/3	038701
760 N-2	760 N-2/2	030507			
760 N-3	760 N-3/2	030521	Fixing clamp for 880 KF, 900 KF	880 KF-01	050123
760 N-4	760 N-4/2	030545	ditto for 880 A KF, 900 A KF	880 A KF-01	050130
Set consisting of:					
spindle, screw and pin for 779	779/3	031085			

SPARE PARTS ⑤	HAZET No.	EAN-No. 4000896+	SPARE PARTS ⑤	HAZET No.	EAN-No. 4000896+
Repair Set consisting of: hinged section, screw and lock washer for 8814	8814/3	042050	Repair Set for shift lever consisting of: shift lever, screws, ball, compression spring for 1116	1116/6	003228
Repair Set for ratchet wheel 10 = 3/8" ■ consisting of: ratchet wheel with quick-release press-button, pawl, cap screws, 1 holding down bolt each (small and large), for 8816 N	8816 N/6	042197	Repair Set for ratchet wheel 25 = 1" ■ consisting of: shift lever, screws, ball, compression spring, pawl, ratchet wheel for 1116	1116/8 N	003235
Repair Set for shift lever consisting of: shift lever, screws, ball, compression spring for 8816 G, 8816 GK, 8816 P, 8816 S, 8816 ST 2264-1, 6110 CT, 6110-1 CT, 6111-1 CT, 6114-1 CT, 6115-1 CT 6402-1, 6402-1 S, 6408-1	8816 P/5	042227	Repair Set for ratchet wheel 25 = 1" ■ consisting of: shift lever, screws, ball, compression spring, pawl, ratchet wheel for 1116	1116/8 N	003235
Repair Set for ratchet wheel 10 = 3/8" ■ consisting of: ratchet wheel, pawl, shift lever, screws, ball, compression spring for 8816 G, 8816 GK, 8816 P, 8816 ST, 6110 CT, 6110-1 CT, 6111-1 CT, 6114-1 CT, 6115-1 CT, 6402-1	8816 P/7 N	042234	Spare Blades for inside hexagon Screwdriver Sockets 986-4 986-5 986-6 986-7 986-8 986-10	986-04 986-05 986-06 986-07 986-08 986-010	065141 065158 088850 065172 065189 065196
Repair Set for ratchet wheel 10 = 3/8" ■ consisting of: ratchet wheel, pawl, shift lever, screws, ball, compression spring for 8816 S, 6402-1 S	8816 S/7	048465	for inside hexagon Screwdriver Sockets, long style 986 Lg-5 986 Lg-6 986 Lg-7 986 Lg-8 986 Lg-10	986 Lg-05 986 Lg-06 986 Lg-07 986 Lg-08 986 Lg-010	065202 065219 065226 065332 065349
Plastic handle for 8814, 8816 P, 8816 F, 8816 G, 8816 GK, 2593 Lg-17	8816 KG-02	042166	for inside hexagon Screwdriver Sockets extra-long style 986 S Lg-6 986 S Lg-8	986 S Lg-06 986 S Lg-08	065356 065363
Repair Set for joint connection consisting of: screw and lock washer for 8814, 8816 G, 8816 GK	8816 G-013	042111	for inside hexagon Screwdriver Sockets with ball hex 986 KK-5 986 KK-6 986 KK-7 986 KK-8 986 KK-10 986 KK-12	986 KK-05 986 KK-06 986 KK-07 986 KK-08 986 KK-010 986 KK-012	065370 065387 065394 065400 065417 065424
Repair Set consisting of: hinged section, screw and lock washer for 914-15 and 914-18	914/3	046065	for inside Screwdriver Sockets with internal serration (XZN) 990-5 990-6 990-8 990-10 990-12	990-05 990-06 990-08 990-010 990-012	065431 065448 065455 065462 065479
Repair Set for joint connection, consisting of: screw and lock washer for 914-15, 914-18, 916 GK	916 G-013	046188	for inside Screwdriver Sockets with internal serration (XZN) long style 990 Lg-6 990 Lg-8 990 Lg-10 990 Lg-12	990 Lg-06 990 Lg-08 990 Lg-010 990 Lg-012	065486 065493 065509 065516
Plastic handle for 916 F, 916 SP, 2574, 2574-1	916 KG-02	046225	for inside Screwdriver Sockets with internal serration (XZN) extra-long style 990 S Lg-10 990 S Lg-12	990 S Lg-010 990 S Lg-012	065523 065530
Plastic handle for 916 and 2577-2	916 KG-03	046232	for inside spline Screwdriver Sockets (RIBE CV) 991-5 991-6 991-8 991-10 991-12 991-14 991-16	991-05 991-06 991-08 991-010 991-012 991-014 991-016	065547 065554 065561 065578 065585 065592 065608
Plastic handle for 914-15, 914-18, 916 GK, 771-17, 771-19, 771-21, 771 A-13/16, 772	916 KG-04	046249	for inside TORX® Screwdriver Sockets 992-T 20 992-T 25 992-T 27 992-T 30 992-T 40 992-T 45 992-T 50	992-T 020 992-T 025 992-T 027 992-T 030 992-T 040 992-T 045 992-T 050	065486 065493 065509 065516
Repair Set for ratchet wheel 12.5 = 1/2" ■ consisting of: ratchet wheel with quick-release press-button, pawl, cap screws, 1 holding down bolt each (small and large), for 916 N	916 N/6	046270			
Repair Set for ratchet wheel 12.5 = 1/2" ■ consisting of: shift lever, 2 screws, ball, compression spring, ratchet wheel and pawl for 916 S, 916 SP, 916 GK	916S/7	046300			
Repair Set for ratchet wheel 12.5 = 1/2" ■ consisting of: shift lever, 2 screws, ball and compression spring for 916 S, 916 SP, 916 GK	916 SP/5	046331			
Repair Set for ratchet wheel 12.5 = 1/2" ■ consisting of: shift lever, screws, ball, compression spring, ratchet wheel and pawl for 916 SP, 916 GK	916 SP/7-1	046348			
Repair Set for shift lever consisting of: shift lever, screws, ball, compression spring for 1016, 1016/2, 6132-1 CT, 6143 CT, 6143-1 CT, 6144 CT, 6144-1 CT, 6145 CT, 6145-1 CT, 6146-1 CT	1016/6	001972			
Repair Set for ratchet wheel 20 = 3/4" ■ consisting of: ratchet wheel, pawl, shift lever, screws, ball, compression spring for 1016, 1016/2, 6132-1 CT, 6143 CT, 6143-01, 6143-1 CT, 6144 CT, 6144-01, 6144-1 CT, 6145 CT, 6145-01, 6145-1 CT, 6146-1 CT	1016/8 N	001989			

SPARE PARTS ⑤	HAZET No.	EAN-No. 4000896+	SPARE PARTS ⑤	HAZET No.	EAN-No. 4000896+
for tamper resistant TORX® Screwdriver Sockets			Nosepiece 1.8 mm hole ϕ	1963-01018	008896
992-T 30 H	992-T 030 H	065790	ditto 2.4 mm hole ϕ	1963-01024	008902
992-T 40 H	992-T 040 H	065806	ditto 2,7 mm hole ϕ	1963-01027	008919
992-T 45 H	992-T 045 H	065813	ditto 2,9 mm hole ϕ	1963-01029	008926
992-T 50 H	992-T 050 H	065820	ditto 3,2 mm hole ϕ	1963-01032	008933
Various spare parts	1806-01	006175	Pivot pin -012*		
Telescopic spring for 1805-3, 1806-1 up to -4			ditto -013*		
Hickory handle for body and fender hammers 1935, 1937 K, 1938K, 1939 K, 1940, 1942, 1943, 1949-2	1900-01	007417	Snap ring -014*		
ditto for 1944, 1945, 1949-1	1900-02	007424	Grip for body -015*		
Repair Set consisting of: 1 pair of jaws, 15 mm wide, 2 screws and 2 sleeves for 1932-1, -2, -5	1932-1/6	007820	Grip for handle -016*		
Repair Set consisting of: 1 pair of jaws, 30 mm wide, 2 screws and 2 sleeves for 1932-1, -2, -5	1932-2/6	007905	Replaceable punching set consisting of: punch, die plate, screw and headless screw for 1964-50	1964-050	008995
Repair Set consisting of: 1 die, 1 pan and 2 headless screws for 1932-6	1932-6/4	007981	ditto for 1964-55	1964-055	009008
2 lock nuts and 2 screws for joint in 1932 and 1964	1932-004	007783	ditto for 1964-70	1964-070	009015
Telescopic spring for 1932 and 1964	1932-005	007790	Cutter crowns , set of 10 parts for 1967	1967-01	009329
Rubber tip for 1948	1948-50	008308	Center for 1967	1967-02	009336
Handle for 1950	1950-010	008346	Plastic cap for 1973-1	1973-01	009657
Hickory handle for 1952-23	1952-01	008360	Mirror and 2 light bulbs for 1977-1	1977-01/3	009794
for 1952-28	1952-02	008377	Plastic clip, empty, for 2100/6 H	2100/6 HL	011568
for 1952-35	1952-03	008407	Plastic clip, empty, for 2105 Lg/9 H	2105 Lg/9 H L	012022
for 1952-40	1952-04	008421	Plastic clip, empty, for 2116 Lg/8 H	2116 Lg/8 HL	051502
for 1952-50	1952-05	008445	Hickory handle for hammer 2140-2	2140-020	012589
for 1952-60	1952-06	008469	ditto for 2140-3	2140-030	012596
Set consisting of: 1 handle and 2 screws for 1959-3	1959-03/3	008711	ditto for 2140-4	2140-040	012602
Spare blade with 3 pins for 1960	1960-01	008742	ditto for 2140-5	2140-050	012619
Set consisting of: 1 spring, 1 screw sleeve, 2 Unbrako-screws, 2 lock washers for 1961	1961-01/6	008773	ditto for 2140-8	2140-080	012626
Spare knife for 1962 N	1962 N-1	008834	ditto for 2140-10	2140-0100	012572
Springs for 1962 N	1962 N-2	008841	Scriber tip, 2 mm ϕ , for 2150-2	2150-02	013029
Set of screws for 1962 N	1962 N-4	008858	Diaphragm for Stethoscope 2151	2151-01	013050
Template for 1962 N	1962 N-5	008865	Ear tips for 2151	2151-02/2	062287
Plastic washer for 1962 N	1962 N-6	008872	Tubular lamp (Soffitte) for 2153	2153-00	013128
Spare parts for Hand Riveting Tool 1963			Set consisting of: Strap and rivet for 2170	2170/2	013388
* = available in set only			Strap for 2171-5	2171-05	013395
Set consisting of: grip for body 1963-015, grip for handle 1963-016	1963/02	008964	ditto for 2171-6	2171-06	013401
Set consisting of: jaw pusher 1963-06, jaw pusher spring 1963-07, cap screw 1963-08	1963/03	008971	Adapter for 2172	2172-1	013494
Set consisting of: 1 bolt 1963-012, 2 bolts 1963-013, 2 snap rings 1963-014	1963/05	008988	Tension element with O-Ring for 2173-1	2173-1/5	013548
Jaw housing	1963-04	008940	for 2173-2	2173-2/5	013579
Jaws (2 parts)	1963-05	008957	Spare Parts 2174		
Jaw pusher -06*			Center body	2174-01	013616
Jaw pusher spring -07*			Lock nut (large wheel)	2174-02	013623
Cap screw -08*			Tension nut (small wheel)	2174-03	013630
			Center shaft	2174-04	013647
			Large collet 22 mm ϕ	2174-05	013654
			ditto 15 mm ϕ	2174-06	013661
			Tommy screw for 2193	2193-03	014026
			Tommy nut for 2193	2193-04	014033
			Eye bolt for 2193	2193-05	014040
			Repair Set for ratchet wheel 6.3 = 1/4" \circ consisting of: ratchet wheel, pawl, shift lever, screws, ball, compression spring for 2264	2264/7	015917
			Repair Set for ratchet wheel 6.3 = 1/4" \circ consisting of: ratchet wheel, pawl, shift lever, screws, ball, compression spring for 2264-1, 6408-1	2264-1/7	015900

SPARE PARTS ⑤	HAZET No.	EAN-No. 4000896+	SPARE PARTS ⑤	HAZET No.	EAN-No. 4000896+
Plastic-Roll for 2460/19	2460/19 TL	050369	for Torque Wrenches SYSTEM 6000 CT Please note the following features: 1 shift lever burnished (black) 2 replaceable head 3 since 1985 ergonomic plastic handle Drive nominal size 10 = 3/8" x 12.5 = for 6010-1 CT Drive nominal size 12.5 = 1/2" x 20 = 3/4" for 6021-1 CT, 6022-1 CT, 6023-1 CT Drive nominal size 20 = 3/4" x 20 = 3/4" for 6021-1 CT, 6022-1 CT, 6023-1 CT Repair Set for lock consisting of: lock spring, lock cap, cylinder, key, 2 headless screws for 6110 CT Repair Set for twist lock consisting of: lock spring, twist lock with 2 headless screws for 6010-1 CT, 6110-1 CT, 6290-1 CT Repair Set for lock consisting of: lock spring, lock cap, cylinder, key, 2 headless screws for 6121 CT, 6122 CT, 6123 CT Repair Set for twist lock consisting of: lock spring, twist lock with 2 headless screws for 5121-2 CLT, 5122-2 CLT, 5123-2 CLT 6021-1 CT, 6022-1 CT, 6023-1 CT, 6111-1 CT, 6115-1 CT, 6121-1 CT, 6122-1 CT, 6123-1 CT, 6127-1 CT, 6128-1 CT, 6291-1 CT, 6291-2 CT 6292-1 CT, 6293-1 CT, 6722 TAC, 6792 TAC Repair Set for optical signal transmitter consisting of: red button, compression spring, black housing, pin, screw for 6021-1 CT, 6022-1 CT, 6023-1 CT, 6110 CT, 6110-1 CT, 6111-1 CT, 6114-1 CT, 6115-1 CT, 6121 CT, 6121-1 CT, 6122 CT, 6122-1 CT, 6123 CT, 6123-1 CT, 6127-1 CT, 6128-1 CT, 6191-2 CT, 6290-1 CT, 6291-1 CT, 6292-1 CT, 6293-1 CT Repair Set for shift lever consisting of: shift lever, screws, ball, compression spring, spring washer, lockring for 5121-2 CLT, 5121-2 CT, 5122-2 CLT, 5122-2 CT, 5122 ST-1 5123-2 CLT, 5123-2 CT, 6121-1 CT, 6121 CT, 6122-1 CT, 6122 CT, 6123-1 CT, 6123 CT, 6127-1 CT, 6128-1 CT, 6291-2 CT Repair Set for ratchet wheel 12.5 = 1/2" ■ consisting of: ratchet wheel, pawl, shift lever, screws, ball, compression spring, spring washer, lockring for 5121-2 CLT, 5121-2 CT, 5122-2 CLT, 5122-2 CT, 5122 ST-1 5123-2 CLT, 5123-2 CT, 6121 CT, 6121-1 CT, 6122-1 CT, 6122 CT, 6123-1 CT, 6123 CT, 6127-1 CT, 6128-1 CT, 6722 TAC Reversible ratchet with screw, complete (exchangeable): 20 = 3/4" ■ until end of 2004 for 6132-1 CT, 6143 CT, 6143-1 CT, 6144 CT, 6144-1 CT, 6145 CT, 6145-1 CT, 6146-1 CT Repair Set for cylinder lock consisting of: cylinder, lock cap, lock spring, key and cylinder lock for 6143 CT, 6144 CT, 6145 CT		
Plastic fulcrum with pin and lock ring for 2577-2	2577-02	016921			
Fixing bolt for 2577-207/2 and -208/2	2577-201	016952			
Retainer M 7 – without fixing bolt - ditto M 8	2577-207 2577-208	016969 016983			
Screwdriver Bit TORX® T 45 for 2597	2597-01	017386			
Spring for 2769-3	2769-30	017812			
Set consisting of: socket, screw and lock washer for 2944-10 2944-14	2944-10/3 2944-14/3	018321 018345			
Spare tips (pair) for Special Pliers 4659-1	4659-01/2	103249			
Repair kit for chain 4682-01	4682-01/9	057214			
Tommy screw for 4682	4682-02	061747			
Tommy bar for 4762, 4762-1	4762-4	049448			
Rubber retainer for 880 TZ-20,8 (13/16") 880 Lg-20,8 900 TZ-20,8 900 Lg-20,8 962 2505-1 2505-2 4762 4764	4762-5	049455			
ditto for 4762, 2506	4762-6	049462			
Tommy bar for 3761, 3861	4767-04	049486			
Tommy bar for 4767 KF, 4767 A KF, 4767 A MgT-1	4767-42	049479			
Ring, black with screw for 4810 A	4810 A-01	076338			
Ring cover, with pin for 4810 A	4810 A-02	076376			
Eyeshade, rubber, black for 4810 A	4810 A-03	076383			
Optic adjusting screw for 4810 A	4810 A-04	076390			
Sight glass for 4810 B	4810 B-01	082537			
Pipette for 4810 A, 4810 B	4810 B-05	082650			
Scale Plate for 4851-1	4851-01	057115			
Replacement set for Spring Vice 4900-1 A and -2 A consisting of 5 straight pins and 2 O-rings	4900-02/7	063437			
Repair Set consisting of: ratchet wheel, complete, pawl, shift lever, 2 screws, ball and compression spring for 4910-1	4910-1/7	064533			
Spindle-shaped button for 4970-2	4970-02	053001			
O-Ring 4 mm ø for 4970-1 and 4970-2	4970-04	053018			
for Torque Wrenches 5000 CT					
Sliding square tang 10 = 3/8" ■ for 5110-1 CT	5110-01	049691			
Sliding square tang 10 = 3/8" ■ for 5110 CT, 5110 ST, 5110-1	5110-02	022373			
Sliding square tang 12.5 = 1/2" ■ for 5121-1 CT, 5122-1 CT 5123-1 CT	5121-01	022410			
Sliding square tang 12.5 = 1/2" ■ for 5121 CT, 5121 ST, 5121-1, 5122 CT, 5122 ST, 5122-1 5123 CT, 5123 ST, 5123-1	6414-1	027675			
			6010-02	023639	
			6021-03	023653	
			6043-04	024575	
			6110-26	025046	
			6110-27	025053	
			6122-26	025282	
			6122-27	025299	
			6122-29	025305	
			6122/7	025329	
			6122/9 N	025343	
			6143-01	111190	
			6144-0/5	025503	

SPARE PARTS ⑤	HAZET No.	EAN-No. 4000896+	SPARE PARTS ⑤	HAZET No.	EAN-No. 4000896+
Repair Set for twist lock consisting of: twist lock, lock spring and cylinder screw for 6132-1 CT, 6143-1 CT, 6144-1 CT, 6145-1 CT, 6243-1 CT, 6244-1 CT, 6245-1 CT, 6246-1 CT, 6294-1 CT, 6295-1 CT, 6296-1 CT	6144-01/3	025527	Repair Set for shift lever consisting of: shift lever, screws, ball, compression spring for 1016, 1016/2, 6132-1 CT, 6143 CT, 6143-1 CT, 6144 CT, 6144-1 CT, 6145 CT, 6145-1 CT, 6146-1 CT	1016/6	001972
Reversible ratchet with pin , complete (exchangeable): 20 = 3/4" ■ since 2005 for 6132-1 CT, 6144 CT, 6144-1 CT, 6145 CT, 6145-1 CT, 6146-1 CT	6145-01	111206	Repair Set for ratchet wheel 20 = 3/4" ■ consisting of: ratchet wheel, pawl, shift lever, screws, ball, compression spring for 1016, 1016/2, 6132-1 CT, 6143 CT, 6143-01, 6143-1 CT, 6144 CT, 6144-01, 6144-1 CT, 6145 CT, 6145-01, 6145-1 CT, 6146-1 CT	1016/8 N	001989
Torque insert lock with screw for 6243-1 CT, 6244-1 CT, 6245-1 CT, 6294-1 CT, 6295-1 CT until end of 2004, 6296-1 CT until end of 2004	6294-01	026180	Repair Set for ratchet wheel 6.3 = 1/4" ○ consisting of: ratchet wheel, pawl, shift lever, screws, ball, compression spring for 2264	2264/7	015917
Torque insert lock with pin since 2005 for 6295-1 CT, 6296-1 CT	6296-01	111213	Repair Set for ratchet wheel 6.3 = 1/4" ○ consisting of: ratchet wheel, pawl, shift lever, screws, ball, compression spring for 2264-1, 6408-1	2264-1/7	015900
Repair Set for shift lever consisting of: shift lever, screws, ball, compression spring for 6108-1 CT, 6109-1 CT, 6109-2 CT, 6401-1, 6401-1 S, 6408	6401-1/5	111176	Battery charger for 7292-1 EC	7292-230	050604
Repair Set for ratchet wheel 6.3 = 1/4" ■ consisting of: ratchet wheel, pawl, shift lever, screws, ball, compression spring for 6108-1 CT, 6109-1 CT, 6109-2 CT, 6401-1	6401/7	111169			
Repair Set for ratchet wheel 6.3 = 1/4" ■ consisting of: ratchet wheel, pawl, shift lever, screws, ball, compression spring for 6401-1 S	6401-1 S/7	111152			
Repair Set for shift lever consisting of: shift lever, screws, ball, compression spring, spring washer, lockring for 6403-1, 6403-1 S, 6404-1, 6404-1 S	6403-1/7	070756			
Repair Set for ratchet wheel 12.5 = 1/2" ■ consisting of: ratchet wheel, pawl, shift lever, screws, ball, compression spring, spring washer, lockring for 6403-1, 6404-1	6403-1/9	070749			
Repair Set for ratchet wheel 12.5 = 1/2" ■ consisting of: ratchet wheel, pawl, shift lever, screws, ball, compression spring, spring washer, lockring for 6403-1 S, 6404-1 S	6403-1 S/9	070817			
Repair Set for ratchet wheel 6.3 = 1/4" ○ consisting of: ratchet wheel, pawl, shift lever, screws, ball, compression spring for 6408	6408/7	111145			
Slipping clutch for Mechanical Angle Dial 6690	6910-01	029334			
Repair Set for shift lever consisting of: shift lever, screws, ball, compression spring for 8816 G, 8816 GK, 8816 P, 8816 S, 8816 ST 2264-1, 6110 CT, 6110-1 CT, 6111-1 CT, 6114-1 CT, 6115-1 CT 6402-1, 6402-1 S, 6408-1	8816 P/5	042227			
Repair Set for ratchet wheel 10 = 3/8" ■ consisting of: ratchet wheel, pawl, shift lever, screws, ball, compression spring for 8816 G, 8816 GK, 8816 P, 8816 ST, 6110 CT, 6110-1 CT, 6111-1 CT, 6114-1 CT, 6115-1 CT, 6402-1	8816 P/7 N	042234			
Repair Set for ratchet wheel 10 = 3/8" ■ consisting of: ratchet wheel, pawl, shift lever, screws, ball, compression spring for 8816 S, 6402-1 S	8816 S/7	048465			

Boxes, empty	HAZET No.	EAN-No. 4000896+		Inserts	HAZET No.	EAN-No. 4000896+	
without plastic insert, to be ordered separately				PUR = foam inserts PL = plastic inserts for boxes on page 169			
for tool set				suitable for tool set			
plastic 805/7, 806/7, 807/7, 808/7	205x125x20	805 KL	032679	430-1	430-1 PL	019700	
plastic 850, 850-1, 851, 850 A, 850 TQ, 851 AZ, 880 MgT/4, 1557/9, 1557/10, 2200/36	167x97x37	850 KL	037582	435-11	435-11 PL	079797	
metal 1557/22, 2800/18	225x128x46	853 KL	038312	450 N/8	450/8 PL	061761	
plastic 844/4, 852 N, 852-1, 854, 854-1, 852 A N, 854 F, 852 A-1, 880 G/8, 1557/32	187x125x39	854 KL	038398	536/15	536-1 PUR	077205	
plastic 436 N/11, 669-1, 849, 855, 880-1, 880 N-1, 884 N-1, 884 AN-1, 880 ZN-1, 884 ZN-1, 884 AZ N-1, 1557/29, 2240/103, 2240/95	279x121x47	880-1 KL	039012	600 N/8	600 N/8 PL	057139	
plastic 536/15, 853, 880-2, 882, 885 N, 889 N, 932 N, 938 N, 932 ZN, 1557/21, 2575/144, 4910/13	344x188x56	885 KL	042586	613/6	613/6 PL	071333	
metal 430-1, 881 AZ, 900 S, 905, 905 Z, 905 AZ, 1555/64, 6290-1 CT/29	435x215x62	900 KL	043866	669-1	669-1 PUR	089192	
plastic 900, 906, 907, 954 N, 900 A N, 900 Z, 906 Z, 907 Z, 900 AZ, 907 AZ, 932 AZ N, 907 AMZ, 1557/58	410x216x65	901 KL	045716	793/3	793/3 PL	031580	
Bottom part for Box 0-111/116	410x216x65	901 KL-UT	058112	800/6	800/6 PL	055319	
metal 793/3, 880 AZ N-1, 985, 4793/3	320x128x58	930 KL	046522	801/6	801/6 PL	083190	
metal 888 N, 888 Z N, 888 AZ N, 1000, 1002, 1000 Z, 1002 Z, 1000 AZ, 1002 AZ, 1530 M/49, 1530A/38, 1550/32, 1900/6, 4500/42, 6292-1 CT/20, 6292-1 CT/28	578x235x88	1000 KL	001200	803/6, 803/6-1, 803/6-2	803/6 PL	083176	
metal 1100, 1100 Z	780x319x113	1100 L	002191	803/10	803/10 PL	083183	
metal 1905/10 N	755x310x120	1905 KL	007455	803/13	803/13 PL	098521	
metal 2191/12 K, 2191A/10 K, 2191 MA/18 K, 2193/4 K, 2575/104	290x173x50	2191 KL	013975	805/7, 806/7, 807/7, 808/7	805/7 PL	032662	
metal 985, 986/9, 990/9, 992/9, 1557 N/9, 1557/15, 1557 N/17, 1557/20, 2272/17, 2351/15	320x128x58	2272 KL	015993	844/4	844/4 PUR	035861	
wood 4660-1/12 up to 4660-34/10		4660/12 KL	057566	844/5	844/5 PUR	035885	
wood 4660/18		4660/18 KL	062720	849	849 PUR	036172	
plastic 4930		4930 KL	089667	850	850-PUR	036813	
plastic 4970/6		4970 KL	089253	850-1	850-1 PUR	036356	
				851, 851 AZ	851 PUR	038183	
				852 N	852 N-PUR	038305	
				852-1	852-1 PUR	038244	
				852 A N	852 A N-PUR	038282	
				852 A-1	852 A-1 PUR	038268	
				854	854 PUR	049523	
				854 F	854 F-PUR	071500	
				854-1, 854 T	854-1 PUR	038367	
				855	855 PUR	038466	
				880-1	880-1 PUR	039029	
				880 N-1, 880 Z N-1	880 N-1 PUR	040933	
				880-2	880-2 PUR	039074	
				880 MgT/4	880 MgT/4 PUR	040919	
				880 G/8	880 G PUR	040636	
				880 AZ N-1	880 AZ N-1 PUR	040919	
				881 AZ	880 PL	040940	
				882	882 PUR	042470	
				884 N-1	884 N-1 PUR	042548	
				884 A N-1	884 A N-1 PUR	042500	
				884 AZ N-1	884 AZ N-1 PUR	042524	
				885 N	885 N PUR	042609	
				888 N, 888 Z N, 888 AZ N Top and bottom	888 PL	042630	
				889 N	889 N PUR	042678	

Inserts	HAZET No.	EAN-No. 4000896+	Inserts	HAZET No.	EAN-No. 4000896+
PUR = foam inserts PL = plastic inserts for boxes on page 169			PUR = foam inserts PL = plastic inserts for boxes on page 169		
suitable for tool set			suitable for tool set		
900 AZ, 900 A N	900 A N PUR	043521	2500 PL/10	2500-3 PL	076673
900, 900 Z	900 PUR	044078	2500 PL/10	2500-4 PL	076680
900 S	900 S-PL	057122	2500 PL/10	2500-5 PL	077137
905, 905 Z, 905 AZ	905 PL	045860	2800/18	2800/18 PL	018208
906, 906 Z	906 PUR	045914	4500/42	4500-1 PL	020300
907, 907 Z	907 PUR	045990	6290-1 CT/29	6290-1/29 PL	026036
907 AMZ	907 AMZ PUR	045976	6292-1 CT/20	6292-1/20 PL	026111
923/4	923 PL	061181	6292-1 CT/28	6292-1/28 PL	026128
932 N, 932 Z N	932 N PUR	046560			
932 AZ N	932 AZ N PUR	046546			
938 N	938 N PUR	046614			
954 N	954 N PUR	046638			
985	985 PL	046867			
986/9	986/9 PL	051571			
990/9, 992/9, 1557 N/9	992/9 PL	051588			
1000, 1000 Z, 1002 AZ	1000-3 PL	000777			
1000 AZ	1000-2 PL	000685			
1002, 1002 Z	1000-1 PL	000630			
1530 M/49, 1530 A/38 Top and bottom	1530 PL	003532			
1550/32 Top and bottom	1550 PL	003655			
1555/64	1555 PL	003686			
1557/9	1557/9 PUR	003938			
1557/10	1557/10 PUR	003747			
1557/15	1557/15 PL	003778			
1557 N/17	1557 N/17 PL	003952			
1557/20	1557/20 PL	003815			
1557/21	1557/21 PUR	003839			
1557 N/22	1557 N/22 PL	003976			
1557/29	1557/29 PUR	003853			
1557/32	1557/32 PUR	003877			
1557/58	1557/58 PUR	003891			
2191/12 K, 2191A/10 K, 2191 MA/18 K	2191 PL	013999			
986-P/5, 990-P/5, 992 H-P/5	2191-1 PL	054350			
990 S Lg-P/3	2191-11 PL	054367			
990 KK-P/6	2191-22 PL	054381			
986 S Lg-P/5	2191-3 PL	054374			
2193/4 K	2193 PL	014095			
2220/36	2200/36 PUR	063390			
2240/95, 2240/103	2240/103 PUR	015429			
2272/17	2272 PL	016006			
2351/15	2351 PL	016228			
2500 PL/10	2500-1 PL	076659			
2500 PL/10	2500-2 PL	076666			

Application	HAZET No.	Vehicle model	Page
ALFA			
Brakes			
Cleaning disk brake calipers	4968-1 -2		147
Drivetrain			
Retaining the pulley e.g. on generator	4640-1 4640-2	V-ribbed belt pulley V-belt pulley	132
Tightening screws as a function of the torsion angle (e.g. cylinder head bolts)	6690		157
Exhaust system			
Cutting exhaust pipes up to 2.5 mm wall thickness and 80 mm ϕ	4682		138
Hose coupling			
Installing and removing self-gripping spring band hose clamps	798-15 A		45
Installing and removing self-gripping spring band hose clamps	798-7		44
Installing and removing spring band hose clamps (on cooling and heating circuits)	798-12		45
Motor electricity			
Installing and removing spark plugs (span 16 mm = $\frac{5}{8}$ ")	4766-1	multi-valve engines	139
Spark plug cleaning	2131		96
Wheels			
Installing and removing tire valve cores	666-1		37
Mounting and removing tires (steel / aluminium rims)	650 K-20		37
Pulling rubber-covered valves of different sizes into the rim holes of tubeless tires	666-2		37
BMW			
Body			
Door lock pin – screwed connection	2117-T 40	E 34	95
Installing and removing the nuts at the pull switch, the lighting switch and the fan switch	2566-2	M3 (E30), Z1 (3-series until 1987)	110
Installing and removing the seat panel and adjusting the steel sliding roof	2223 Lg-T 25	3- and 5-series	103
Brakes			
Adjustment of sensors at the antilocking system	2147 MS		96
Brake bleeding (span 7 mm)	4968-7		147
Brake caliper screws (span 7 mm) replacement of brake linings	2901 G-7	3- and 7-series	121
Brake caliper screws (span 7 mm) replacement of brake linings	986-7	3-, 5- and 7-series	67
Cleaning disk brake calipers	4968-1 -2		147
Installing and removing the hand brake cable of drum brakes	4968-4		147
Removing rust and dust from bore holes	4961-18/51		146
Screws at the brake lines ABS (span 11 and 12 mm)	4966-11 -12		147
Chassis			
Coil spring operation when replacing shock absorbers	4900-11/2 and 4900-2 A	5-series (E 34), 730i (E 32)	143
Coil spring operation when replacing shock absorbers	4900-12/2 and 4900-2 A	Z 3, 318i (E 36), 528i (E 39)	143
Coil spring operation when replacing shock absorbers	4900-13/2 and 4900-2 A	3-series (E 36)	143
Coil spring operation when replacing shock absorbers	4900-22/4 and 4900-2 A	3-series (E 46)	143
Coil spring operation when replacing shock absorbers	4900-23/4 and 4900-2 A	530i, 540i (E 39), 7-series (E 38)	143
Coil spring operation when replacing shock absorbers	4900-231, -23, 4900-2 A	Special plastic insert for the operation of the front axle springs on BMW since 2001 E65: 730i, 735i, 740i, 745i E66: 735Li, 745Li	143
Installing and removing the wheel bearing (set with 12 parts in plastic box)	4930-29/12		145
Repair work at the spring strut, e.g shock absorbers, bearings of shock absorber legs, coil springs	4910/13		145
Repair work at the spring strut, retaining the piston rod	4911-8 and 4900/13		145
Screws of the shock absorber piston rod (stabilizing bearing/spring leg) – consider BMW installation instructions –	2927	3-, 5- and 7-series	121
Steering – Removing ball joint pivots (size 18 - 22 mm)	779		42
Steering – Removing ball joint pivots (size 20 - 22 mm)	779-1		42
Wheel bearing unit, front fastening nut (span 46 mm)	1000-46	316, 318, 320, 323, 325, M3 (motor-sport)	71
Wheel bearing unit, rear fastening nut (span 30 mm)	1000 Z-30	316, 318, 320, 323, 325, M3 (motor-sport)	71
Drivetrain			
Control of the anti-freezing acid concentration	4810 B		141
Cylinder head bolts (outside TORX® screws E 12)	2925	engine M 42, 1.8 l, 4 cyl. with 4-valve technique 318is since 1989, engine M 50, 2.0 l, 2.5 l 6 cyl. with 4-valve technique, serie 5 since 1991	121
Identification of leaks in the cooling system	4800/9		140
Pushing valve stem seals (ϕ 7 and 8 mm)	2977		121

Application	HAZET No.	Vehicle model	Page
BMW			
Drivetrain			
Removing valve stem seals	2991	multi-valve engines	121
Removing valve stem seals (2-valve engines)	791-5	2-valve engines	43
Retaining the pulley e.g. on generator	4640-1 4640-2	V-ribbed belt pulley V-belt pulley	132
Tightening screws as a function of the torsion angle (e.g. cylinder head bolts)	6690		157
Exhaust system			
Cutting exhaust pipes up to 2.5 mm wall thickness and 80 mm ϕ	4682		138
Installing and removing the lambda probe (span 22 mm)	4681-1	316, 318 with M 43 engine, 320, 325 with M 20 engine, 750i with M 70 engine	138
Installing and removing the lambda probe (span 22 mm)	4681-3	520 – 525 (M 20)	138
Installing and removing the lambda probe (span 22 mm)	4681-4		138
Installing and removing the rubber retainers of exhaust systems	4684-1		138
Universal application of the lambda probe (span 22 mm)	4680-5		138
Fuel supply			
Carburettor adjusting (Pierburg), idle running and CO	4517		130
Injection type engine – mixture control at the flow distributor (K-Jetronic)	4516		130
Installing and removing the injection nozzle (span 27 mm)	4555-1	diesel M 21: E 30 = 324 TD, E 28 = 524 TD, E 34 = 524 TD; diesel M 51: E 36 = 325 TD, E 34 = 525 TDS	131
Screws on injection pipes (span 17 mm)	4550	diesel engines	130
Gearbox / Shaft			
Axle shaft nut	900 S Z-36	5-series	75
Extension (575 mm long) for deeply located screws	958-23		66
Gearbox screws (outside TORX® screws E 10, E 12, E 14)	880 G-E 10, 12, 14	3-series E30 until 1989, E36 since 1989, 5-series E28 until 1989	55
Installing axle collar clamps	1847-1		84
Installing clutch plates (ϕ 15 - 28 mm cone)	2174		100
Screws at the switchgear of automatic gearbox	2223-T 27		103
Screws at the switchgear of automatic gearbox	992-T 27	Gearbox 3 HP 22, 4 HP 22	68
Hose coupling			
Installing and removing hose clamps on cooling and heating circuits (span 6 and 7 mm)	426-6 -7		29
Motor electricity			
Installing and removing glow plug sockets	4760-5	new generation of diesel engines	139
Installing and removing glow plugs (span 12 mm)	4760-1	diesel	136
Installing and removing pencil type glow plugs (span 12 mm)	880 TZ-12	diesel	58
Installing and removing relays	4770-1		139
Installing and removing spark plugs (span 16 mm = $\frac{5}{8}$ ")	880 A KF	multi-valve engines	58
Installing and removing spark plugs (span 16 mm = $\frac{5}{8}$ ")	4766-1	multi-valve engines	139
Installing and removing spark plugs (span 17.5 mm = $\frac{11}{16}$ ")	880 A Mg T-3	M 3, M 5 (motor-sport)	58
Installing and removing spark plugs (span 20.8 mm = $\frac{13}{16}$ ")	880 KF	2-valve engines	58
Installing and removing the V-ribbed belt pulley at the generator (BOSCH)	4641/2		132
Releasing of cable contacts (assortment with 10 parts in wooden box)	4660-29/10		134
Spark plug cleaning	2131		96
Spark plugs – checking the spark plug air gap	2147		96
Oil Service			
Installing and removing the oil filter cap	2169-36	MERCEDES-BENZ engine 116, 100D Transporter, BMW, OPEL Vectra B DI 16 V, VW Lupo TDI, model year 1999	99
Steering			
Airbag screw (tamper resistant TORX® screws T 30)	2223-T 30 H		103
Screw at the steering wheel lock (outside TORX® screws E 8)	850-E 8		53
Wheels			
Installation of tire pressure sensors and the corresponding special tire valves	669-1		38
Installing and removing tire valve cores	666-1		37
Mounting and removing tires (steel / aluminium rims)	650 K-20		37
Pulling rubber-covered valves of different sizes into the rim holes of tubeless tires	666-2		34

CHRYSLER

Brakes			
Adjustment of sensors at the antilocking system, resp. checking the spark plug air gap	2147 MS		96
Cleaning disk brake calipers	4968-1 -2		147

Application	HAZET No.	Vehicle model	Page
CHRYSLER			
Drivetrain			
Cylinder head bolts	900 Lg-14	VM diesel engines	64
Cylinder head bolts (span 1/2" American size)	3551-1	Jeep Wrangler, Cherokee, Grand Cherokee (2.5 and 4.0 engines)	125
Retaining the pulley e.g. on generator	4640-1 4640-2	V-ribbed belt pulley V-belt pulley	132
Tightening screws as a function of the torsion angle (e.g. cylinder head bolts)	6690		157
Exhaust system			
Cutting exhaust pipes up to 2.5 mm wall thickness and 80 mm ϕ	4682		138
Fuel supply			
Locking device at the fuel line and at the tank ventilation	4501-1	Neon 1.8 / Stratus 2.0 / 2.5	129
Wheels			
Installing and removing tire valve cores	666-1		37
Mounting and removing tires (steel / aluminium rims)	650 K-20		37
Pulling rubber-covered valves of different sizes into the rim holes of tubeless tires	666-2		37
CITROËN			
Body			
Removing the sleeves (ϕ 3.85 mm) at the door hinge bushes	1970 with 1970-1	BX	91
Removing the sleeves (ϕ 5.5 mm) at the door hinge bushes	1970 with 1970-4	CX	91
Brakes			
Brake bleeding (span 8 and 9 mm)	4968-8 -9		147
Cleaning disk brake calipers	4968-1 -2		147
Installing and removing the hand brake cable of drum brakes	4968-4		147
Readjusting brake pistons	4970/6		147
Chassis			
Installing and removing the wheel bearing (set 15 parts in plastic box)	4930-2/15		145
Drivetrain			
Control of the anti-freezing acid concentration	4810 B		141
Cylinder head bolts (span 17 mm)	3432		124
Identification of leaks in the cooling system	4800/9		140
Retaining the pulley e.g. on generator	4640-1 4640-2	V-ribbed belt pulley V-belt pulley	132
Tightening screws as a function of the torsion angle (e.g. cylinder head bolts)	6690		157
Exhaust system			
Cutting exhaust pipes up to 2.5 mm wall thickness and 80 mm ϕ	4682		138
Fuel supply			
Injection lines of HDi engines	4548-14		130
Screws at fuel injection pipe (span 13 mm), installing and removing the toothed belt	4561		131
Hose coupling			
Installing and removing hose clamps (cooling and heating circuits)	798-9		44
Installing and removing self-gripping spring band hose clamps	798-15 A		45
Installing and removing self-gripping spring band hose clamps	798-7		44
Installing and removing spring band hose clamps (on cooling and heating circuits)	798-12		45
Motor electricity			
Installing and removing relays	4770-1		139
Spark plug cleaning	2131		96
Spark plugs – 14 mm	4766-2	C5 with 2.0 l HPi engine, RENAULT Kangoo 1.2l 16V engine, Twingo, Clio	139
Spark plugs – checking the spark plug air gap	2147		96
Wheels			
Installation of tire pressure sensors and the corresponding special tire valves	669-1		38
Installing and removing tire valve cores	666-1		37
Mounting and removing tires (steel / aluminium rims)	650 K-20		37
Pulling rubber-covered valves of different sizes into the rim holes of tubeless tires	666-2		34

Application	HAZET No.	Vehicle model	Page
DAIHATSU			
Body			
Installing and removing the safety device of the window crank	799		45
Brakes			
Adjustment of sensors at the antilocking system	2147 MS		96
Brake bleeding (span 8 mm)	4968-8		147
Cleaning disk brake calipers	4968-1 -2		147
Drivetrain			
Identification of leaks in the cooling system	4800/9 and 4800-11		140
Retaining the pulley e.g. on generator	4640-1 4640-2	V-ribbed belt pulley V-belt pulley	132
Exhaust system			
Cutting exhaust pipes up to 2.5 mm wall thickness and 80 mm ϕ	4682		138
Fuel supply			
Installing and removing the injection nozzle (span 27 mm)	4555 N	diesel	131
Motor electricity			
Installing and removing relays	4770-1		139
Wheels			
Installing and removing tire valve cores	666-1		37
Mounting and removing tires (steel / aluminium rims)	650 K-20		37
Pulling rubber-covered valves of different sizes into the rim holes of tubeless tires	666-2		37
FIAT			
Brakes			
Adjustment of sensors at the antilocking system	2147 MS		96
Brake bleeding (span 7 mm)	4968-7		147
Brake bleeding (span 8 mm)	4968-8		147
Cleaning disk brake calipers	4968-1		147
Fixing springs of the hand brake shoes (rear drum brakes)	797		44
Installing and removing the hand brake cable of drum brakes	4968-4		147
Replacement of disk brake linings (front ϕ 4 mm)	748 Lg b-4	Seicento, Cinquecento, Punto	39
Rotation of pistons of Altecna-Bendix floating calipers	4960-1		146
Chassis			
Coil spring operation when replacing shock absorbers	4900-10/2 and 4900-2 A	Panda, Punto	143
Coil spring operation when replacing shock absorbers	4900-12/2 and 4900-2 A	Barchetta, Punto, Tempra	143
Coil spring operation when replacing shock absorbers	4900-13/2 and 4900-2 A	Marea, Ulysse	143
Steering – Removing ball joint pivots (size 18 - 22 mm)	779		42
Steering – Removing ball joint pivots (size 20 - 22 mm)	779-1		42
Drivetrain			
Compressing valve springs	792-2	Panda, Uno, Tipo	43
Control of the anti-freezing acid concentration	4810 B		141
Cylinder head bolts (XZN screws M 12)	991-12	2.0 l engines	68
Identification of leaks in the cooling system	4800/9		140
Retaining the pulley e.g. on generator	4640-1 4640-2	V-ribbed belt pulley V-belt pulley	132
Tightening screws as a function of the torsion angle (e.g. cylinder head bolts)	6690		157
Exhaust system			
Cutting exhaust pipes up to 2.5 mm wall thickness and 80 mm ϕ	4682		138
Gearbox / Shaft			
Endless hose clamps on axle collars	1847-10		84
Installing clutch plates (ϕ 15 - 28 mm cone)	2174		100
Hose coupling			
Installing and removing self-gripping spring band hose clamps	798-15 A		45
Installing and removing self-gripping spring band hose clamps	798-7		44
Motor electricity			
Installing and removing relays	4770-1		139
Installing and removing spark plugs (span 16 mm = $\frac{5}{8}$ "	4762-1	Uno 45 ie with cat. with Fire engines	136
Spark plug cleaning	2131		96
Spark plugs – checking the spark plug air gap	2147		96
Wheels			
Installing and removing tire valve cores	666-1		37
Mounting and removing tires (steel / aluminium rims)	650 K-20		37

Application	HAZET No.	Vehicle model	Page
FIAT			
Wheels			
Pulling rubber-covered valves of different sizes into the rim holes of tubeless tires	666-2		34
FORD			
Body			
Adjusting the nozzles of the washing system	4850-1		142
Angular adjustment of the wiper blades (consider regulations of car maker)	4851-1	Galaxy, Explorer, Maverick	142
Extraction of dowel pins \varnothing 8 mm of door hinges	1971 with 1971-1	Fiesta, Escort since 1986	91
Extraction of dowel pins \varnothing 10 mm of door hinges	1971 with 1971-2	Fiesta since 1989	91
Installing and removing the safety device of the window crank	799		45
Reboring welding spots \varnothing 9 mm (esp. at the axle)	1967-90	Mondeo	91
Removing the sleeves (\varnothing 3.85 mm) at the door hinge bushes	1970 with 1970-1	Fiesta	91
Removing the sleeves (\varnothing 5.5 mm) at the door hinge bushes	1970 with 1970-4	Fiesta	91
Brakes			
Adjustment of sensors at the antilocking system	2147 MS		96
Brake bleeding (span 7, 8, 9, 10 mm)	4968-7 -8 -9 -10		147
Brake caliper screws (span 7 mm) replacement of brake linings	986-7		67
Cleaning disk brake calipers	4968-1 -2		147
Installing and removing the hand brake cable of drum brakes	4968-4		147
Readjusting brake pistons	4970/6		147
Chassis			
Axle nut screws (span 2.1/4" American size)	1000 AZ-2.1/4	Transit	71
Coil spring operation when replacing shock absorbers	4900-10/2 and 4900-2 A	Escort, Escort 1.4 i	143
Extracting the full floating axle (pitch circle \varnothing 100 - 150 mm)	1969-14		91
Installing and removing the wheel bearing (set with 10 parts in plastic box)	4930-34/10		145
Steering – Removing ball joint pivots (size 18 - 22 mm)	779		42
Steering – Removing ball joint pivots (size 20 - 22 mm)	779-1		42
Drivetrain			
Compressing valve springs	792-1	Fiesta, Escort	43
Cylinder head bolts (inside TORX® screws T 55)	992 S Lg-T 55		68
Cylinder head bolts (inside TORX® screws T 70)	992 Lg-T 70	1.8 l diesel (Turbo) Fiesta, Escort, Sierra, P 100 since 8/1992	68
Cylinder head bolts (set 6 parts for screws with internal serration XZN)	3090/6		122
Cylinder head bolts (XZN screws M 10 and M 12)	990 S Lg-10 -12	OHC-engines	68
Identification of leaks in the cooling system	4800/9 and 4800-13	Galaxy	140
Keeping installed valves raised M 14 x 1.25 and M 18 x 1.5	3428	except CVH and multi-valve engines	124
Removing valve stem seals	2991	Fiesta since 1996	121
Removing valve stem seals (2-valve engines)	791-5	2-valve engines	43
Removing valve stem seals (4-valve engines)	791-8	multi-valve engines	43
Retaining the pulley e.g. on generator	4640-1 4640-2	V-ribbed belt pulley V-belt pulley	132
Screws at the intake bridge (inside TORX® screws T 45)	992 S Lg-T 45	Scorpio 2.4, 2.8, 2.9 l injection	68
Tightening screws as a function of the torsion angle (e.g. cylinder head bolts)	6690		157
Toothed belt tensioning pulley (inside TORX® screws T 50)	2115-T 50	1.6 l diesel Fiesta, Escort, Orion	94
Valves – depressing bucket tappets	3474	1.6 l D Fiesta, Escort, Orion, 1.8 l D (since 1989) Fiesta, Escort, Orion, 1.8 l TD Sierra	124
Valve adjusting	3499	1.6 l D Fiesta, Escort, Orion, 1.8 l D (since 1989) Fiesta, Escort, Orion, 1.8 l TD Sierra	124
Exhaust system			
Cutting exhaust pipes up to 2.5 mm wall thickness and 80 mm \varnothing	4682		138
Installing and removing the lambda probe (span 22 mm)	4681-1	Fiesta 1.1, 1.6 l, Escort, Orion 1.4 l	138
Installing and removing the lambda probe (span 22 mm)	4681-2	Fiesta 1.3 HCS, Escort 1.3 l, Mondeo 1.6 and 2.0 l 16 V	138
Installing and removing the lambda probe (span 22 mm)	4681-3	Scorpio 2.0 l	138
Installing and removing the rubber retainers of exhaust systems	4684-1	Fiesta, Orion, Escort	138
Universal application of the lambda probe (span 22 mm)	4680-5		138
Fuel supply			
Carburettor adjusting (Pierburg), idle running and CO	4517		130
Installing and removing the injection nozzle (span 27 mm)	4555 N		131
Installing and removing the injection nozzle (span 27 mm)	4555-1	Diesel Lincoln Continental (USA), Lincoln Mark VII, VII LSC	131
Gearbox / Shaft			
Extension (575 mm long) for deeply located screws	958-23		66
Installing axle collar clamps	1847-1		84
Installing clutch plates (\varnothing 15 - 28 mm cone)	2174		100
Installing special steel clamps on axle collars made of Hytrel®	1847		84

Application	HAZET No.	Vehicle model	Page
FORD			
Hose coupling			
Installing and removing self-gripping spring band hose clamps	798-15 A		45
Installing and removing self-gripping spring band hose clamps (cooling and heating circuits)	798-7		44
Installing and removing spring band hose clamps (on cooling and heating circuits)	798-12		45
Motor electricity			
Installing and removing glow plugs (span 12 mm)	4760-1	diesel	136
Installing and removing relays	4770-1		139
Installing and removing spark plugs (span 16 mm = 5/8")	4766-1	multi-valve engines	139
Installing and removing the V-ribbed belt pulley at the generator (BOSCH)	4641/2		132
Releasing of cable contacts (assortment with 10 parts in wooden box)	4660-34/10		134
Spark plug cleaning	2131		96
Spark plugs – checking the spark plug air gap	2147		96
Wheels			
Installing and removing tire valve cores	666-1		37
Mounting and removing tires (steel / aluminium rims)	650 K-20		37
Pulling rubber-covered valves of different sizes into the rim holes of tubeless tires	666-2		37
HONDA			
Brakes			
Adjustment of sensors at the antilocking system	2147 MS		96
Brake bleeding (span 8 and 10 mm)	4968-8 -10		147
Cleaning disk brake calipers	4968-1 -2		147
Readjusting brake pistons	4970/6		147
Drivetrain			
Identification of leaks in the cooling system	4800/9 and 4800-11		140
Retaining the pulley e.g. on generator	4640-1 4640-2	V-ribbed belt pulley V-belt pulley	132
Tightening screws as a function of the torsion angle (e.g. cylinder head bolts)	6690		157
Exhaust system			
Cutting exhaust pipes up to 2.5 mm wall thickness and 80 mm ø	4682		138
Gearbox / Shaft			
Installing clutch plates (ø 15 - 28 mm cone)	2174		100
Motor electricity			
Installing and removing relays	4770-1		139
Installing and removing spark plugs (span 16 mm = 5/8")	4766-1	multi-valve engines	139
Spark plug cleaning	2131		96
Spark plugs – checking the spark plug air gap	2147		96
Wheels			
Installing and removing tire valve cores	666-1		37
Mounting and removing tires (steel / aluminium rims)	650 K-20		37
Pulling rubber-covered valves of different sizes into the rim holes of tubeless tires	666-2		37
ISUZU			
Brakes			
Adjustment of sensors at the antilocking system	2147 MS		96
Cleaning disk brake calipers	4968-1 -2		147
Chassis			
Coil spring operation when replacing shock absorbers	4900-11/2 and 4900-2 A		143
Drivetrain			
Cylinder head bolts (span 17 mm)	3432		124
Identification of leaks in the cooling system	4800/9 and 4800-11		140
Retaining the pulley e.g. on generator	4640-1 4640-2	V-ribbed belt pulley V-belt pulley	132
Tightening screws as a function of the torsion angle (e.g. cylinder head bolts)	6690		157
Exhaust system			
Cutting exhaust pipes up to 2.5 mm wall thickness and 80 mm ø	4682		138
Motor electricity			
Installing and removing relays	4770-1		139

Application	HAZET No.	Vehicle model	Page
ISUZU			
Wheels			
Installing and removing tire valve cores	666-1		37
Mounting and removing tires (steel / aluminium rims)	650 K-20		37
Pulling rubber-covered valves of different sizes into the rim holes of tubeless tires	666-2		37
JAGUAR			
Brakes			
Cleaning disk brake calipers	4968-1 -2		147
Drivetrain			
Retaining the pulley e.g. on generator	4640-1 4640-2	V-ribbed belt pulley V-belt pulley	132
Tightening screws as a function of the torsion angle (e.g. cylinder head bolts)	6690		157
Exhaust system			
Cutting exhaust pipes up to 2.5 mm wall thickness and 80 mm ϕ	4682		138
Motor electricity			
Installing and removing spark plug sockets	1849-2	12-cylinder engines	84
Wheels			
Installing and removing the tire valve cores	666-1		37
Mounting and removing tires (steel / aluminium rims)	650 K-20		37
Pulling rubber-covered valves of different sizes into the rim holes of tubeless tires	666-2		37
MAZDA			
Brakes			
Adjustment of hand brake (span 10 mm)	4965-1		147
Adjustment of sensors at the antilocking system	2147 MS		96
Brake bleeding (span 8 mm)	4968-8		147
Cleaning disk brake calipers	4968-1 -2		147
Union nut at the brake pressure regulator (span 12 mm)	6612 c-12		156
Union nut at the main brake cylinder (span 14 mm)	6612 c-14		156
Chassis			
Coil spring operation when replacing shock absorbers	4900-11/2 and 4900-2 A	626 1992 model	143
Drivetrain			
Cylinder head bolts (inside TORX® screws T 70)	992 Lg-T 70	121 since 1996	68
Identification of leaks in the cooling system	4800/9 and 4800-11		140
Retaining the pulley e.g. on generator	4640-1 4640-2	V-ribbed belt pulley V-belt pulley	132
Tightening screws as a function of the torsion angle (e.g. cylinder head bolts)	6690		157
Exhaust system			
Cutting exhaust pipes up to 2.5 mm wall thickness and 80 mm ϕ	4682		138
Fuel supply			
Installing and removing the injection nozzle (span 27 mm)	4555 N	diesel	131
Motor electricity			
Installing and removing relays	4770-1		139
Installing and removing spark plugs (span 16 mm = $\frac{5}{8}$ ")	4766-1	323 F, 626, multi-valve engines	139
Spark plug cleaning	2131		96
Spark plugs – checking the spark plug air gap	2147		96
Wheels			
Installing and removing tire valve cores	666-1		37
Mounting and removing tires (steel / aluminium rims)	650 K-20		37
Pulling rubber-covered valves of different sizes into the rim holes of tubeless tires	666-2		34
MERCEDES-BENZ			
Body			
Installing and removing the fixing clamps of the chrome-moulding	2724-1	W 124, W 140, W 202 E-, S- and C-class	115
Installing and removing the Mercedes-star	2735	S-class (W 140), E-class (W 124 since 1993), C-class (W 202)	116
Screws at the door handle (for inside TORX® screws T 20)	2715-T 20	A-class (type 168), C-class (type 203)	115
Brakes			
Adjustment of sensors at the antilocking system	2147 MS		96

Application	HAZET No.	Vehicle model	Page
MERCEDES-BENZ			
Brakes			
Brake bleeding (span 9 and 11 mm)	4968-9 and -11		147
Brake line screws (span 11 and 14 mm)	6612 c-11 -14		156
Cleaning disk brake calipers	4968-1 -2		147
Extracting disk brake linings (rear)	1966-1		91
Fixing springs of drum brake linings (rear)	2796-1	A-class (type 168)	117
Fixing springs of the hand brake shoes (rear disk brakes)	2730		116
Installing and removing draw springs (hand brake shoes of rear disk brakes)	4964-1		146
Safety bolts on rear disk brakes	748 Lg b-3	E-class 211	39
Safety bolts (∅ 4 mm) on rear disk brakes	748 Lg b-4		39
Chassis			
Coil spring operation when replacing shock absorbers	4900-14/2 and 4900-2 A	E-class 4MATIC, type 210 (since 06/1995)	143
Coil spring operation when replacing shock absorbers	4900-15/2 and 4900-2 A	A-class, type 168 (since 10/1997)	143
Coil spring operation when replacing shock absorbers	4900-16/2 and 4900-2 A	ML-class, type 163 (since 03/1998)	143
Coil spring operation when replacing shock absorbers	4900-17/2 and 4900-2 A	Vito, V-class	143
Extracting the outside collar of tapered roller bearing	788-37 and -1437	W 123	43
Installing and removing the wheel bearing (set with 12 parts in plastic box)	4930-27/12	A-class (type 168), C-class (type 202), E-class (type 210)	145
Retaining the self-locking nut on rubber bearing at the rear axle differential (span 17 mm)	2719-17		115
Shock absorber (upper fastening screw span 16 mm)	2780-16	C-class, type 202 (up to 2000), E-class, type 210	117
Shock absorber (upper fastening screw span 17 mm)	2780	C-class, type 202 (up to 2000), E-class, type 210, SLK, type 170	117
Shock absorber (upper joggle joint)	2780-1	C-class, type 203 (since 2000)	117
Steering – Removing ball joint pivots (size 18 - 22 mm)	779		43
Steering – Removing ball joint pivots (size 20 - 22 mm)	779-1		42
Drivetrain			
Cylinder head bolts (inside TORX® screws T 55)	992 Lg-T 55	C-class, type 202	68
Cylinder head bolts (set 6 parts for screws with internal serration XZN)	3090/6		122
Cylinder head bolts (span 10 mm)	986 Lg-10	207, 307, 208, 308	67
Cylinder head bolts (span 8 mm)	986 S Lg-8	M 115, 116, 117	67
Cylinder head bolts (XZN screws M 10)	2751	types: W 201 (190/190 E)	116
Cylinder head bolts (XZN screws M 10 and M 12)	990 S Lg-10 -12	116, 117	68
Cylinder head bolts (XZN screws M 12)	2752	types: M 104 6-Zyl., M 119 8-Zyl., M 120 12 cyl. multi-valve engines	116
Fastening nut at the fuel injection pump	2742-13	types: 615, 616	116
Identification of leaks in the cooling system	4800/9 and 4800-14	type 168 (A-class)	140
Identification of leaks in the cooling system	4800/9 and 4800-15	type 202 / 203 (C-class), 124 / 210 (E-class) and 129 / 220 (S-class)	140
Identification of leaks in the cooling system	4800/9 and 4800-16	SLK, CLK/SLC, Sprinter since 1999, 208D, 210D, 212D, 214, 314	140
Installing and removing the starter	2755		116
Installing and removing the starter, extension with pin locking device (575 mm),	2762		117
Installing valve stem seals (∅ 7mm)	2777	multi-valve engines: M 104, M 119, M 120	117
Keeping installed valves raised M 14 x 1.25	2728	multi-valve engines	115
Keeping installed valves raised M 14 x 1.25 and M 18 x 1.5	3428	2-valves engines	124
Operation of the belt tensioning pulley and mounting of the V-ribbed belt	2714-1	A-class, type 168	115
Removing valve stem seals (2-valve engines)	791-5	2-valve engines	43
Removing valve stem seals (∅ 7 mm) (pliers offset)	2791	multi-valve engines	117
Removing valve stem seals (straight pliers)	2791-1	multi-valve engines	117
Retaining the pulley e.g. on generator	4640-1 4640-2	V-ribbed belt pulley V-belt pulley	132
Screws at the cooling water circulation pump, water hose connection, intake pipe	2740	M 103, M 104, engine M 103 to M 120 (Diesel) M 601, M 603, M 604	116
Screws of the left camshaft wheel	2718-E 18	M 112 (6 cyl.), M 113 (8 cyl.) C-, E- and S-class	115
Tightening screws as a function of the torsion angle (e.g. cylinder head bolts)	6690		157
Valve adjusting (span 14 mm) to be used in pairs	2769	types: 200 D, 220 D, 240 D, 240 TD	117
Valve adjusting (span 14 mm)	2770-2	types: passenger cars except diesel, 250 CD and 3.5 I-types	117
Valve adjusting (span 17 mm)	2770-3	passenger cars except with diesel engines, 250 CD and 3.5 I	117
Valve adjusting (span 17 mm)	2770-4	M 116 (3.5 I, 4.5 I V8 engines)	117
Valve adjusting (span 17 mm)	2771	types: 280, 280 C, 280 E, 280 CE, 280 S, 280 SE, 280 SL, 280 SLC	117
Valve adjusting (span 30 mm) with 2769	2769-3 and 2769	types: 240 D 3,0, 300 SD, 300 GD, 300 D, 300 TD, 300 CD, 406 D, 207 D, 307 D, 407 D	117
Various repair works, e.g. at the engine	2747 to 2750		116

Application	HAZET No.	Vehicle model	Page
MERCEDES-BENZ			
Exhaust system			
Cutting exhaust pipes up to 2.5 mm wall thickness and 80 mm ϕ	4682		138
Installing and removing the lambda probe (span 22 mm)	612-19 x 22	with 2-valve technique up to 9/1993	34
Installing and removing the lambda probe (span 22 mm)	4680-2		138
Installing and removing the rubber retainers of exhaust systems	4684-1 -2		138
Fuel supply			
Carburettor adjusting (Pierburg), idle running and CO	4517	2-valve engines	130
Injection type engine – installing and removing the pressure control valve holder (injection pump)	4556	601, 602, 603, 605, 606, 615, 616, 617	131
Installing and removing the fuel overflow line (overflow oil line)	1841-33	MB 604, 605 and 606 with 4-valve-technique	72
Installing and removing the injection nozzle (span 27 mm)	4555 N	diesel	131
Mounting and dismounting fuel return lines	4565-1	diesel engines: 601, 602, 603	
Mounting and dismounting of injection nozzle (span 22 mm)	4550-22	diesel engines: type 201, 202 (engines 604, 605, 606)	130
Operation of the fuel line screws at the gasoline tank	2757-22	type 124 E-class, 126 S-class, 129 S-class, type 201, 190	130
Screws on injection pipes (span 14 mm)	4550-14	types: 4 cyl. diesel 601, 190 D, C 200 D, E 200 D, Turbo-Diesel, 603, G 300 D, G 350 D, Turbo, cross-country vehicle, E 300 D, Turbo, S 350 TD	130
Gearbox / Shaft			
Extension (575 mm long) for deeply located screws	958-23		66
Gearbox screws (span 16 mm) standard gearbox	2756-16	class C type 202 (up to 2000)	116
Gearbox screws (span 17 mm) standard gearbox	2756-17		116
Installing and removing circlips at the homocinetic joint 2 nd speed (standard gearbox)	1847-3		84
Installing and removing circlips at the homocinetic joint; retainer ring at the propeller shaft	1847-3		84
Installing and removing standard gearbox (span 19 mm)	2756-19	in conjunction with 2762	116
Installing and removing stop springs on shift linkage (shift and automatic transmission)	2725		115
Installing axle collar clamps	1847-1		84
Nut at the main shaft (span 41 mm)	1000 Z-41		71
Nut on joint flange at the main shaft (span 30 mm)	1000 Z-30		71
Oil pressure pipe (span 12 mm) on clutch operating cylinder (standard gearbox)	2757-12		116
Progressively adjustable clamps without lug-holding-down device	1847-11		84
Retaining the self-locking nut on rubber bearing at the rear axle differential (span 17 mm)	2719-17		115
Screws on cardan shafts (XZN screws M 10)	2751	types: 190/190 E	116
Hose coupling			
Installing and removing hose clamps on cooling and heating circuits (span 6 and 7 mm)	426-6 -7		29
Installing and removing hose clamps (supplementary air valve)	798-4	injection engine	44
Installing and removing self-gripping spring band hose clamps	798-15 A		45
Installing and removing self-gripping spring band hose clamps	798-7		44
Installing and removing spring band hose clamps (on cooling and heating circuits)	798-12		45
Motor electricity			
Installing and removing glow plug sockets	4760-5	new generation of diesel engines	139
Installing and removing glow plugs (span 10 mm)	2530	CDi diesel engines	109
Installing and removing glow plugs (span 12 mm)	4760-1	Typ 201, 202 (4-valve diesel engines)	136
Installing and removing glow plugs (span 12 mm) and conductor rails (span 8 mm)	4760-8 x 12		139
Installing and removing relays	4770-1		139
Installing and removing spark plug sockets	1849-1		84
Installing and removing spark plugs (span 16 mm = $\frac{5}{8}$ ")	2776	types: M 104, 6 cyl., 24 V, M 120, 12 cyl., 48 V, M 119, 8 cyl., 32 V	117
Installing and removing spark plugs (span 16 mm = $\frac{5}{8}$ ")	4767 A KF	types: M 102 (190-230), M 103 (6 cyl. 260 E, 360 E)	136
Installing and removing spark plugs (span 20.8 mm = $\frac{13}{16}$ ")	4767 KF	except 615, 616, 617 and M 102	136
Installing and removing the V-ribbed belt pulley at the generator (BOSCH)	4641/2		132
Installing and removing wedge base bulbs	4659-1		133
Releasing of cable contacts (assortment with 12 parts in wooden box)	4660-27/12		134
Spark plugs 16 mm	4766		139
Spark plugs – checking the spark plug air gap	2147		96
Oil Service			
Installing and removing the oil filter cap	2169-27	Type 168 (A-class)	99
Installing and removing the oil filter cap	2169-36	engine 116 MB, 100 D Transporter, OPEL Vectra B DI 16V, BMW, VW Lupo TDI, model year 1999	99

Application	HAZET No.	Vehicle model	Page
MERCEDES-BENZ			
Steering			
Installing and removing the airbag unit (inside TORX® screws T30)	2223 Lg-T 30		103
Wheels			
Installation of tire pressure sensors and the corresponding special tire valves	669-1		38
Installing and removing tire valve cores	666-1		37
Mounting and removing tires (steel / aluminium rims)	650 K-20		37
Pulling rubber-covered valves of different sizes into the rim holes of tubeless tires	666-2		37
Wheel bolts (span 17 mm)	902 S Lg-17		75
Wheel bolts (span 17 mm)	903 S Lg-17		76
mitsubishi			
Brakes			
Cleaning disk brake calipers	4968-1 -2		147
Drivetrain			
Identification of leaks in the cooling system	4800/9 and 4800-11		140
Retaining the pulley e.g. on generator	4640-1 4640-2	V-ribbed belt pulley V-belt pulley	132
Tightening screws as a function of the torsion angle (e.g. cylinder head screws)	6690		157
Exhaust system			
Cutting exhaust pipes up to 2.5 mm wall thickness and 80 mm ø	4682		138
Fuel supply			
Installing and removing the injection nozzle (span 27 mm)	4555 N	diesel	131
Motor electricity			
Spark plug cleaning	2131		96
Wheels			
Installing and removing tire valve cores	666-1		37
Mounting and removing tires (steel / aluminium rims)	650 K-20		37
Pulling rubber-covered valves of different sizes into the rim holes of tubeless tires	666-2		37
NISSAN			
Brakes			
Adjustment of sensors at the antilocking system	2147 MS		96
Brake bleeding (span 10 and 11 mm)	4968-10 -11		147
Cleaning disk brake calipers	4968-1 -2		147
Installing and removing the hand brake cable of drum brakes	4968-4		147
Chassis			
Coil spring operation when replacing shock absorbers	4900-10/2 and 4900-2 A		143
Coil spring operation when replacing shock absorbers	4900-11/2 and 4900-2 A		143
Coil spring operation when replacing shock absorbers	4900-12/2 and 4900-2 A		143
Coil spring operation when replacing shock absorbers	4900-13/2 and 4900-2 A		143
Extracting the flull floating axle (pitch circle ø 100 - 150 mm)	1969-14	Sunny, Bluebird, Laurel, Patrol, Urvan	91
Steering – Removing ball joint pivots (size 18 - 22 mm)	779		42
Steering – Removing ball joint pivots (size 20 - 22 mm)	779-1		42
Drivetrain			
Identification of leaks in the cooling system	4800/9 and 4800-11		140
Removing valve stem seals (2-valve engines)	791-5	2-valve engines	43
Removing valve stem seals (4-valve engines)	791-8		43
Retaining the pulley e.g. on generator	4640-1 4640-2	V-ribbed belt pulley V-belt pulley	132
Tightening screws as a function of the torsion angle (e.g. cylinder head bolts)	6690		157
Valve adjusting (span 17 mm)	2770-3	Violet 710, A 10, Bluebird 610, 810, 910, Skyline C 110, C 210, Laurel 230, C 31, 260 ZS 30, 280 ZX-T, S 130, Patrol 160, except Stanza (T 11), 280 ZX, 280 ZX-T (S 130)	117
Exhaust system			
Cutting exhaust pipes up to 2.5 mm wall thickness and 80 mm ø	4682		138
Installing and removing the lambda probe (span 22 mm)	4680-1	100 NX 1.6 I, 200 SX 1.8 I, Micra 1.0	138
Fuel supply			
Carburettor adjusting (CO)	2255-1 with 4525-2		104
Carburettor adjusting (CO)	4525-2 with 4525-3		130

Application	HAZET No.	Vehicle model	Page
NISSAN			
Fuel supply			
Installing and removing of injection nozzle (span 22 mm)	4555-3	Terrano TD 25, 27 since 1988	131
Installing and removing the injection nozzle (span 27 mm)	4555 N	diesel	131
Gearbox / Shaft			
Endless hose clamps on axle collars	1847-10		84
Motor electricity			
Installing and removing relays	4770-2		139
Installing and removing spark plugs (span 16 mm = 5/8")	4766-1	multi-valve engines	139
Operation of the reverse gear switch	4373-19		128
Spark plug cleaning	2131		96
Wheels			
Installing and removing tire valve cores	666-1		37
Mounting and removing tires (steel / aluminium rims)	650 K-20		37
Pulling rubber-covered valves of different sizes into the rim holes of tubeless tires	666-2		37
OPEL			
Body			
Door lock pin – screwed connection (inside TORX® screws T 40)	2117-T 40	Astra F	95
Installing and removing the fixing device of the spare wheel (inside tamper resistant TORX® screws T 50)	3092-T 50 H	Frontera Sport	122
Installing and removing the safety device of the window crank	799	Corsa, Kadett, Astra, Vectra, Omega	45
Operation of the deeply located screws of the safety belt casing (B-pillar)	3012-13	Astra G	122
Removing the sleeves (∅ 5 mm) at the door hinge bushes	1970 with 1970-2		91
Brakes			
Adjustment of hand brake (span 10 mm)	4965-1	Vectra B	147
Adjustment of sensors at the antilocking system	2147 MS		96
Brake bleeding (span 9 mm)	4968-9		147
Brake caliper screws (span 7 mm) replacement of brake linings	986-7	Astra, Vectra, Omega, Corsa	67
Brake caliper screws (span 7 mm) replacement of brake linings	2901 G-7	Astra, Vectra, Omega, Corsa	121
Cleaning disk brake calipers	4968-1 -2		147
Extracting disk brake linings (rear)	1966-1		91
Readjusting brake pistons	4970/6		147
Removing rust and dust out of drill holes	4961-22/51		146
Safety bolts (∅ 4 mm) on disk brakes (rear)	748 Lg b-4	Kadett E, Astra F, Vectra A, Calibra A, Omega A, B, Senator A, B	39
Safety bolts (∅ 6 mm) on disk brakes (rear)	748 Lg b-6	Corsa A, Kadett D, E, Ascona B, C, Manta B, Vectra	39
Spring plates with holding device (drum brakes / brake lining)	4963-1		146
Chassis			
Coil spring operation when replacing shock absorbers	4900-11/2 and 4900-2 A		143
Coil spring operation when replacing shock absorbers	4900-12/2 and 4900-2 A		143
Extension	4910-9	especially for Corsa B, Astra F, G, Vectra B	145
Installing and removing the wheel bearing (set with 11 parts in plastic box)	4930-30/11		145
Repair work at the spring strut, e.g shock absorbers, bearings of shock absorber legs, coil springs	4910/13		145
Steering – Removing ball joint pivots (size 18 - 22 mm)	779		42
Steering – Removing ball joint pivots (size 20 - 22 mm)	779-1		42
Drivetrain			
Control of the anti-freezing acid concentration	4810 B		141
Cylinder head bolts (inside TORX® screws T 55)	3092 T-55	Omega V 6	122
Cylinder head bolts (inside TORX® screws T 55)	992 S Lg-T 55		68
Cylinder head bolts (outside TORX® screws E 14)	2580-E 14 and 2581-E 14	V6 engines	111
Cylinder head bolts (set 6 parts for screws with internal serration XZN)	3090/6		122
Cylinder head bolts (XZN screws M 10 and M 12)	990 S Lg-10 -12		68
Identification of leaks in the cooling system	4800/9		140
Removing valve stem seals (2-valve engines)	791-5	2-valve engines	43
Removing valve stem seals (4-valve engines)	2991	Omega B 2.5 I TD	121
Removing valve stem seals (4-valve engines)	791-8	multi-valve engines	43
Retaining the pulley e.g. on generator	4640-1 4640-2	V-ribbed belt pulley V-belt pulley	132
Screws at the cooling pump (cooling water circulation pump span 5 mm)	8801-5	1.3 I OHM-engines	59
Screws at the cooling pump (cooling water circulation pump span 6 mm)	8801-6	1.8, 2.0 I	59
Screws at the cooling pump (cooling water circulation pump span 10 mm)	2572	Kadett 1.2 I, Corsa A 1.0, 1.2 I	110
Screws at the cooling pump (cooling water circulation pump span 11 mm)	880 Lg-11	1.2 I OHC-engines	57

Application	HAZET No.	Vehicle model	Page
OPEL			
Drivetrain			
Screws at the cooling pump (cooling water circulation pump span 13 mm)	880 Lg-13	1.6, 1.8 l	57
Tightening screws as a function of the torsion angle (e.g. cylinder head bolts)	6690		157
Exhaust system			
Cutting exhaust pipes up to 2.5 mm wall thickness and 80 mm ϕ	4682		138
Installing and removing the lambda probe (span 22 mm)	4680-3	Corsa A 1.2i, 1.3i, 1.4i, Corsa B 1.2i, 1.4i, Kadett E 1.3i, 1.4i, 1.6i, 1.8i, Astra F 1.3i, 1.6i, 1.8i, Ascona C 1.6i, Vectra A 1.6i, 1.8 i, Vectra B 1.6i	138
Installing and removing the lambda probe (span 22 mm)	4680-4	Astra G, 1.6	138
Installing and removing the lambda probe (span 22 mm)	4681-2	Vectra, Kadett, Calibra 2.0 l 16 V, Omega B 2.5i and 3.0i	138
Installing and removing the lambda probe (span 22 mm)	4681-3	Vectra, Calibra, Omega A 2.0 l	138
Installing and removing the rubber retainers of exhaust systems	4684-2		138
Fuel supply			
Carburettor adjusting (Pierburg), idle running and CO	4517		130
Screwing of injection nozzles on diesel engines	4516-17	Astra G, Corsa B and C 1.7DTI-16V-engines	130
Installing and removing the injection nozzle (span 27 mm)	4555 N	diesel	131
Locking device at the fuel line and at the tank ventilation	4501-1	Corsa B, Astra F, G, Vectra B, Omega B, CHRYSLER Neon 1.8, Stratus 2.0 and 2.5, RENAULT passenger cars since 1997	129
Screws on injection pipes (span 17 mm)	4550	Omega B 2.5 TD	130
Gearbox / Shaft			
Extension (575 mm long) for deeply located screws	958-23		66
Installing and removing circlips at the homocinetic joint	1847-3		84
Installing axle collar clamps	1847-1		84
Installing special steel clamps on axle collars made of Hytre [®]	1847		84
Hose coupling			
Installing and removing CLIC-type hose clamps	798-2		44
Installing and removing hose clamps (cooling and heating circuits)	798-5		44
Installing and removing hose clamps on cooling and heating circuits (span 6 and 7 mm)	426-6 -7		29
Installing and removing self-gripping spring band hose clamps	798-15 A		45
Installing and removing self-gripping spring band hose clamps	798-7		44
Installing and removing spring band hose clamps (cooling and heating circuits)	798-12		45
Motor electricity			
Installing and removing glow plugs (span 12 mm)	4760-1		139
Installing and removing relays	4770-1		139
Installing and removing relays (offset pattern)	4770-2		139
Installing and removing spark plug sockets	1849	OHC-engines	84
Installing and removing spark plugs (span 16 mm = $\frac{5}{8}$ ")	4766 4766-1	Omega C20X multi-valve engines	139
Installing and removing the back lamp switch (span 19 mm)	2593-19		113
Installing and removing wedge base bulbs	4659-1		133
Releasing of cable contacts (assortment with 12 parts in wooden box)	4660-30/12		134
Spark plug cleaning	2131		96
Spark plugs – checking the spark plug air gap	2147		96
Thermal switch at the radiator fan (span 29 mm)	4815-29	Corsa B, Astra F, G, Vectra A, B,	142
Oil Service			
Installing and removing the oil filter cap	2169-32	Astra, Corsa, VW Passat, AUDI	99
Installing and removing the oil filter cap	2169-36	Vectra B DI 16 V, MERCEDES-BENZ engine 116, 100D Transporter, BMW, VW Lupo TDI, model year 1999	99
Steering			
Installing and removing the airbag unit	2223 Lg-T 30		103
Screw at the steering wheel lock (outside TORX [®] screws E 8)	850-E 8		53
Wheels			
Installing and removing tire valve cores	666-1		37
Mounting and removing tires (steel / aluminium rims)	650 K-20		37
Pulling rubber-covered valves of different sizes into the rim holes of tubeless tires	666-2		37
PEUGEOT			
Body			
Removing the sleeves (ϕ 3.85 mm) at the door hinge bushes	1970 with 1970-1	205, 305, 309	91
Removing the sleeves (ϕ 5 mm) at the door hinge bushes	1970 with 1970-2	504, 505, 605	91

Application	HAZET No.	Vehicle model	Page
PEUGEOT			
Brakes			
Adjustment of sensors at the antilocking system	2147 MS		96
Brake bleeding (span 7 and 11 mm)	4968-7 up to -11		147
Cleaning disk brake calipers	4968-1 -2		147
Extracting disk brake linings	1966-2		91
Installing and removing the hand brake cable of drum brakes	4968-4		147
Chassis			
Coil spring operation when replacing shock absorbers	4900-12/2 and 4900-2 A		143
Installing and removing the wheel bearing (set with 15 parts in plastic box)	4930-2/15		145
Drivetrain			
Cylinder head bolts (span 17 mm)	3432	504 diesel	124
Identification of leaks in the cooling system	4800/9		140
Retaining the pulley e.g. on generator	4640-1 4640-2	V-ribbed belt pulley V-belt pulley	132
Tightening screws as a function of the torsion angle (e.g. cylinder head bolts)	6690		157
Exhaust system			
Cutting exhaust pipes up to 2.5 mm wall thickness and 80 mm ϕ	4682		138
Installing and removing the lambda probe (span 22 mm)	4681-3	106, 205, 306, 309, 405	138
Fuel supply			
Carburettor adjusting (Pierburg), idle running and CO	4517		130
Injection lines of HDi engines	4548-14		130
Installing and removing the injection nozzle (span 27 mm)	4555 N	diesel	131
Hose coupling			
Installing and removing CLIC-type hose clamps	798-2		44
Installing and removing self-gripping spring band hose clamps	798-15 A		45
Installing and removing self-gripping spring band hose clamps (cooling and heating circuits)	798-7		44
Installing and removing spring band hose clamps (on cooling and heating circuits)	798-12		45
Motor electricity			
Installing and removing spark plugs (span 16 mm = $\frac{5}{8}$ ")	4762-1	105, 205, 306, 504	136
Spark plugs – checking the spark plug air gap	2147		96
Wheels			
Installation of tire pressure sensors and the corresponding special tire valves	669-1		38
Installing and removing tire valve cores	666-1		37
Mounting and removing tires (steel / aluminium rims)	650 K-20		37
Pulling rubber-covered valves of different sizes into the rim holes of tubeless tires	666-2		37
PORSCHE			
Brakes			
Adjustment of sensors at the antilocking system	2147 MS		96
Cleaning disk brake calipers	4968-1 -2		147
Chassis			
Extension, special oval profile	4910-71	especially for Cayenne S	145
Repair work at the spring strut	4910/13		145
Drivetrain			
Identification of leaks in the cooling system	4800/9		140
Retaining the pulley e.g. on generator	4640-1 4640-2	V-ribbed belt pulley V-belt pulley	132
Tightening screws as a function of the torsion angle (e.g. cylinder head bolts)	6690		157
Valve adjusting (span 3 mm)	8501 Lg-3 and 863 PC	924 / Turbo	53
Exhaust system			
Cutting exhaust pipes up to 2.5 mm wall thickness and 80 mm ϕ	4682		138
Installing and removing the lambda probe (span 22 mm)	4681-2 -3	911 Turbo	138
Fuel supply			
Injection type engine – mixture control at the flow distributor (K-Jetronic)	4516	924	130
Hose coupling			
Installing and removing self-gripping spring band hose clamps	798-15 A		45

Application	HAZET No.	Vehicle model	Page
PORSCHE			
Hose coupling			
Installing and removing self-gripping spring band hose clamps	798-7		44
Installing and removing spring band hose clamps (on cooling and heating circuits)	798-12		45
Installing and removing self-gripping spring band hose clamps	798-7		44
Installing and removing spring band hose clamps	798-12		45
Motor electricity			
Installing and removing the V-ribbed belt pulley at the generator (BOSCH)	4641/2		132
Spark plug cleaning	2131		96
Wheels			
Installing and removing tire valve cores	666-1		37
Mounting and removing tires (steel / aluminium rims)	650 K-20		37
Pulling rubber-covered valves of different sizes into the rim holes of tubeless tires	666-2		37
RENAULT			
Body			
Removing the sleeves (∅ 5 mm) at the door hinge bushes	1970 with 1970-3		91
Brakes			
Adjustment of sensors at the antilocking system	2147 MS		96
Brake bleeding (span 7, 8, 9, 11 mm)	4968-7 -8 -9 -11		147
Cleaning disk brake calipers	4968-1 -2		147
Installing and removing the hand brake cable of drum brakes	4968-4		147
Rotation of pistons of Altecna-Bendix floating calipers	4960-1		146
Spring plates with holding device (drum brake / brake lining)	4963-1		146
Chassis			
Coil spring operation when replacing shock absorbers	4900-11/2 and 4900-2 A		143
Coil spring operation when replacing shock absorbers	4900-12/2 and 4900-2 A		143
Installing and removing the wheel bearing (set with 12 parts in plastic box)	4930-38/12		145
Steering – Removing ball joint pivots (size 18 - 22 mm)	779		42
Steering – Removing ball joint pivots (size 20 - 22 mm)	779-1		42
Drivetrain			
Control of the anti-freezing acid concentration	4810 B		141
Cylinder head bolts (inside TORX® screws T 55)	992 S Lg-T 55	19 TD	68
Identification of leaks in the cooling system	4800/9 and 4800-10		140
Retaining the pulley e.g. on generator	4640-1 4640-2	V-ribbed belt pulley V-belt pulley	132
Tightening screws as a function of the torsion angle (e.g. cylinder head bolts)	6690		157
Exhaust system			
Cutting exhaust pipes up to 2.5 mm wall thickness and 80 mm ∅	4682		138
Fuel supply			
Carburettor adjusting (Pierburg), idle running and CO	4517		130
Locking device at the fuel line and at the tank ventilation	4501-1	RENAULT passenger cars since 1997	129
Gearbox / Shaft			
Endless hose clamps on axle collars	1847-10		84
Hose coupling			
Installing and removing hose clamps (cooling circuit)	798-6		44
Installing and removing self-gripping spring band hose clamps	798-15 A		45
Installing and removing self-gripping spring band hose clamps	798-7		44
Installing and removing spring band hose clamps (on cooling and heating circuits)	798-12		45
Motor electricity			
Installing and removing glow plugs	4760-8 x 12		139
Installing and removing relays (offset pattern)	4770-2		139
Installing and removing spark plugs (span 16 mm = 5/8")	4762-1	30 TS, R 25 V6 Injection, A 310	136
Installing and removing spark plugs (span 16 mm = 5/8")	4766-1	multi-valve engines	139
Installing and removing wedge base bulbs	4659-1		133
Spark plugs – 14 mm	4766-2	Twingo, Clio, Kangoo with 1.2 l 16 V engine, C2 with 2.0 l Hpi-engine	139
Spark plugs – checking the spark plug air gap	2147		96
Wheels			
Installation of tire pressure sensors and the corresponding tire valves	669-1		38

Application	HAZET No.	Vehicle model	Page
RENAULT			
Wheels			
Pulling rubber-covered valves of different sizes into the rim holes of tubeless tires special tire valves	666-2		37
Installing and removing tire valve cores	666-1		37
Mounting and removing tires (steel / aluminium rims)	650 K-20		37
ROVER			
Brakes			
Adjustment of sensors at the antilocking system	2147 MS		96
Cleaning disk brake calipers	4968-1 -2		147
Drivetrain			
Retaining the pulley e.g. on generator	4640-1 4640-2	V-ribbed belt pulley V-belt pulley	132
Tightening screws as a function of the torsion angle (e.g. cylinder head bolts)	6690		157
Exhaust system			
Cutting exhaust pipes up to 2.5 mm wall thickness and 80 mm ϕ	4682		138
Motor electricity			
Installing and removing spark plugs (span 16 mm = $\frac{5}{8}$ ")	4766-1	213, 800 multi-valve engines	139
Spark plug cleaning	2131		96
Spark plugs – checking the spark plug air gap	2147		96
Wheels			
Installing and removing tire valve cores	666-1		37
Mounting and removing tires (steel / aluminium rims)	650 K-20		37
Pulling rubber-covered valves of different sizes into the rim holes of tubeless tires	666-2		37
SAAB			
Brakes			
Cleaning disk brake calipers	4968-1 -2		147
Extracting disk brake linings (rear)	1966-1		91
Readjusting brake pistons	4970/6		147
Drivetrain			
Retaining the pulley e.g. on generator	4640-1 4640-2	V-ribbed belt pulley V-belt pulley	132
Exhaust system			
Cutting exhaust pipes up to 2.5 mm wall thickness and 80 mm ϕ	4682		138
Motor electricity			
Installing and removing spark plugs (span 16 mm = $\frac{5}{8}$ ")	4766-1	multi-valve engines	139
Wheels			
Installing and removing tire valve cores	666-1		37
Mounting and removing tires (steel / aluminium rims)	650 K-20		37
Pulling rubber-covered valves of different sizes into the rim holes of tubeless tires	666-2		37
SMART			
Drivetrain			
Identification of leaks in the cooling system	4800/9		140
Retaining the pulley e.g. on generator	4640-1 4640-2	V-ribbed belt pulley V-belt pulley	132
Exhaust system			
Cutting exhaust pipes up to 2.5 mm wall thickness and 80 mm ϕ	4682		138
Motor electricity			
Installing and removing spark plugs (span 16 mm = $\frac{5}{8}$ ")	4766-1		139
Spark plug cleaning	2131		96
Wheels			
Installing and removing tire valve cores	666-1		37
Mounting and removing tires (steel / aluminium rims)	650 K-20		37
Pulling rubber-covered valves of different sizes into the rim holes of tubeless tires	666-2		37
Wheel bolts (span 15 mm)	903 S Lg-15		76

Application	HAZET No.	Vehicle model	Page
SUBARU			
Brakes			
Cleaning disk brake calipers	4968-1 -2		147
Drivetrain			
Identification of leaks in the cooling system	4800/9 and 4800-11		140
Retaining the pulley e.g. on generator	4640-1 4640-2	V-ribbed belt pulley V-belt pulley	132
Tightening screws as a function of the torsion angle (e.g. cylinder head bolts)	6690		157
Exhaust system			
Cutting exhaust pipes up to 2.5 mm wall thickness and 80 mm ϕ	4682		138
Wheels			
Installing and removing tire valve cores	666-1		37
Mounting and removing tires (steel / aluminium rims)	650 K-20		37
Pulling rubber-covered valves of different sizes into the rim holes of tubeless tires	666-2		37
SUZUKI			
Brakes			
Brake bleeding (span 10 mm)	4968-10		147
Cleaning disk brake calipers	4968-1 -2		147
Chassis			
Coil spring operation when replacing shock absorbers	4900-10/2 and 4900-2 A		143
Drivetrain			
Retaining the pulley e.g. on generator	4640-1 4640-2	V-ribbed belt pulley V-belt pulley	132
Tightening screws as a function of the torsion angle (e.g. cylinder head bolts)	6690		157
Exhaust system			
Cutting exhaust pipes up to 2.5 mm wall thickness and 80 mm ϕ	4682		138
Motor electricity			
Installing and removing spark plugs (span 16 mm = $\frac{5}{8}$ "")	4766-1	multi-valve engines	139
Wheels			
Installing and removing tire valve cores	666-1		37
Mounting and removing tires (steel / aluminium rims)	650 K-20		37
Pulling rubber-covered valves of different sizes into the rim holes of tubeless tires	666-2		37
TOYOTA			
Body			
Installing and removing the safety device of the window crank	799		45
Brakes			
Adjustment of sensors at the antilocking system	2147 MS		96
Brake bleeding (span 8 and 10 mm)	4968-8 -10		147
Cleaning disk brake calipers	4968-1 -2		147
Safety bolts (ϕ 4 mm) on disk brakes	748 Lg b-4		39
Chassis			
Steering – Removing ball joint pivots (size 18 - 22 mm)	779		42
Steering – Removing ball joint pivots (size 20 - 22 mm)	779-1		42
Drivetrain			
Identification of leaks in the cooling system	4800/9 and 4800-11		140
Retaining the pulley e.g. on generator	4640-1 4640-2	V-ribbed belt pulley V-belt pulley	132
Tightening screws as a function of the torsion angle (e.g. cylinder head bolts)	6690		157
Exhaust system			
Cutting exhaust pipes up to 2.5 mm wall thickness and 80 mm ϕ	4682		138
Fuel supply			
Installing and removing the injection nozzle (span 27 mm)	4555 N	diesel	131
Gearbox / Shaft			
Progressively adjustable clamps without lug-holding-down device	1847-11		84
Wheels			
Installing and removing tire valve cores	666-1		37
Mounting and removing tires (steel / aluminium rims)	650 K-20		37
Pulling rubber-covered valves of different sizes into the rim holes of tubeless tires	666-2		37

Application	HAZET No.	Vehicle model	Page
VOLKSWAGEN GROUP (AUDI, SEAT, SKODA)			
Body			
Adjusting the groove of the front side-windows (for outside TORX® screws E 6)	2565-E 6	Golf III Cabriolet (since 1993) AUDI 100 (since 1991)	110
Adjusting the steel sliding roof (for inside TORX® screws T25)	2223 S Lg-T 25	AUDI 80 and 90	103
Angular adjustment of the wiper blades (consider regulations of car manufacturer)	4851-1	Sharan, SEAT Alhambra	142
Door hinge screws (removing and adjustment)	2597 and 2597-01 or 2251-1/2	Golf III and Vento	113
Door lock pin – screwed connection (inside TORX® screws T 40)	2117-T 40	Golf, Polo, Vento, AUDI 100	95
Installing and removing the driver's and co-driver's door (for inside TORX® screws T 45)	2597 and 2597-01	Golf III (since 1993)	113
Installing and removing the driver's and co-driver's door (for inside TORX® screws T 45)	2597 and 2597-T 45	Golf III (since 1993)	113
Installing and removing the driver's and co-driver's door (for inside TORX® screws T 45)	2597 G-T 45	Polo Classic, Variant, Caddy (since 1995)	113
Installing and removing the driver's and co-driver's door (XZN screws M 10)	2597 and 2597-02	Golf IV, Passat B5	113
Installing and removing the nuts at the pull switch, the lighting switch and the fan switch	2566-2	VW-AUDI	110
Removing the front grille	2520-1	VW transporter T 4 since 1991, Golf IV (since 1998), Bora (since 1999), AUDI TT since 1999)	109
Screws at the door handle (XZN screws M 4)	2565-4	AUDI TT, Golf IV, Passat B5, Lupo, New Beetle, Bora	110
Brakes			
Adjustment of sensors at the antilocking system	2147 MS		96
Brake bleeding (span 7 and 8 mm)	4968-7 and -8	SEAT	147
Brake bleeding (span 7 and 11 mm)	4968-7 and -11		147
Brake caliper screws (span 7 mm) replacement of brake linings	986-7	Golf II, III, IV, Polo, Vento, Lupo	67
Brake lines ø 4.75 mm	2193/4 K	VW-AUDI (except AUDI 100 and 200 with ABS)	101
Cleaning disk brake calipers	4968-1 -2		147
Fixing springs of the hand brake shoes (rear disk brakes)	2730	VW-LT since 1997	116
Installing and removing the hand brake cable of drum brakes	4968-4		147
Readjusting brake pistons	4970/6		147
Removing rust and dust from bore holes	4961-16/51 4961-18/51		146
Spring plates with holding device (drum brake/brake lining)	4963-1		146
Chassis			
Coil spring operation when replacing shock absorbers	4900-10/2 and 4900-2 A	Golf I and II (from 1984 to 1992), Golf II 1.3 I (from 1983 to 1992)	143
Coil spring operation when replacing shock absorbers	4900-11/2 and 4900-2 A		143
Coil spring operation when replacing shock absorbers	4900-12/2 and 4900-2 A	Sharan	143
Coil spring operation when replacing shock absorbers	4900-13/2 and 4900-2 A	AUDI A 100 (model 1991), 100 C 4 (model years 1989-93)	143
Extension, special oval profile	4910-71	especially for VW-Touareg, PORSCHE Cayenne S	145
Installing and removing front spring struts	2593-19 and 2593-1	Polo since 1981, Derby since 1983, Polo Coupé	113
Installing and removing front spring struts	2593-21 and 2593-1	Golf II, Jetta since 1987, Golf III, Vento since 1993, Passat since 1988	113
Installing and removing front spring struts	2593-22 and 2593-1	Golf until 1988, Jetta until 1987, Scirocco, Caddy, Passat, Santana, AUDI 80, Golf III, Vento since 1993, Passat since 1988, Corrado, AUDI 100, 200, AUDI Coupé, AUDI Quattro	113
Installing and removing front spring struts (as retainer span 7 mm)	2593-1	Polo, Derby, Golf, Jetta, Scirocco, Passat, AUDI 80, 100, 200, Coupé	112
Installing and removing rear shock absorbers (retainer with span 50 mm)	2593-50	VW-T 4, Golf III, Vento since 1993	113
Installing and removing rear strut units (retaining the piston rod)	2594	Polo since 1981, Derby since 1982, Polo Coupé, Caddy, Golf I, II, Jetta, Scirocco, LT 28, AUDI 80, AUDI Coupé; VW transporter, LT 28 (control arm axle)	113
Installing and removing rear strut units (span 17 mm)	2593 Lg-17	Passat since 1980, Santana, AUDI 100 since 1982, AUDI 200 since 1983	113
Installing and removing the shock absorber cartridge (span 28 mm)	2593-28	AUDI 80 since 1992, AUDI 90 since 1987, AUDI 200 since 1984	113
Installing and removing the wheel bearing (set 14 parts in plastic box)	4930-25/14		145
Removing the ball joint pivots	779 A-2	AUDI A6 / A8	42
Repair work at the spring strut	4910/13		145
Repair work on shock absorber	2593-3		113
Repair work on shock absorber (front axle)	2593-4	Golf II, III, Jetta, Vento, Passat model year 1988, AUDI 80 model year 1987	113
Repair work on shock absorber (rear axle)	2593-2	Golf I Cabrio, Scirocco, Caddy	113
Steering – Removing ball joint pivots (size 18 - 22 mm)	779		42
Steering – Removing ball joint pivots (size 20 - 22 mm)	779-1		42

Application	HAZET No.	Vehicle model	Page
VOLKSWAGEN GROUP (AUDI, SEAT, SKODA)			
Drivetrain			
Automatic tensioning pulley, toothed belt (span 32 mm)	2587-32	Polo diesel, AUDI 100 since 1991, AUDI A 6, 2.5 l TDi engine	111
Centering cylinder head gaskets	2570/5		110
Centering cylinder head gaskets	2571/5	VW-AUDI, SKODA, SEAT new construction series	110
Operation of the tensioning device	2590-1	Polo, Golf, Passat, Sharan, AUDI (since 1991)	112
Control of the anti-freezing acid concentration – (V.A.G - G 12)	4810 B		141
Cylinder head bolts (outside TORX® screws E 14)	2580-E 14	AUDI V6 engines	111
Cylinder head bolts (outside TORX® screws E 14)	2581-E 14	AUDI 80 V6 with ABS	111
Cylinder head bolts (XZN screws M 10 and M 12)	990 S Lg-10 -12	Polo, Scirocco, Derby, Passat, Golf, AUDI 80, 100	68
Extraction Hook for the Extractor 2510-1 (5 spokes)	2510-8	V8 petrol engines	109
Extraction of camshaft pulleys (5 and 6 spokes)	2510-1	4- and 6-cyl. TDi engines, V6 and V8 engines, AUDI A 4, A 6, A 8	109
Identification of leaks in the cooling system	4800/9	Passat, Golf-Diesel	140
Identification of leaks in the cooling system	4800/9 and 4800-12	AUDI A3, A4, A6, VW-Passat, Golf, Vento	140
Identification of leaks in the cooling system	4800/9 and 4800-13	Sharan	140
Installing and removing plastic and brass inserts (span 13 mm)	2100-13		93
Installing and removing the knock sensor (span 8 mm)	2527-8	AUDI 80 V6 since 7/1992, AUDI 100 V6 since 12/1990	109
Installing and removing the V-belt pulley (span 24 mm)	2590-24	VW-AUDI, T4 since 1991, Golf III/Vento since 1992, Passat since 1988, Corrado since 1989, AUDI 80 since 1992, AUDI 100 since 1991	112
Keeping installed valves raised M 14 x 1.25 and M 18 x 1.5	3428	except multi-valve engines	124
Oil pan screws (span 10 mm)	2528-10	T 4 (2.4 l Diesel/1.8/2.0), Golf I Cabrio, Caddy, Golf II, Jetta from 1984 to 1992, Passat since 1988, Corrado, AUDI 80, 100 since 1987, AUDI 100 since 1991, 4 cyl.	109
Oil pan screws (span 5 mm)	2527-5	Transporter T 4 / 5 cyl. Diesel-engine	109
Operation of Polydrive-cylinder head bolts	2579-9		111
Preloading bucket tappets / valve adjustment	2574	4 cyl. engines until 1982, Golf, Jetta, Caddy, Scirocco, Passat, Iltis, Santana, AUDI 80, 100	110
Preloading bucket tappets / valve adjustment	2574-1	4 cyl. engines since 1983, as well as engines with 5 and 6 cyl. engines, Golf, Jetta, Caddy, Scirocco, Passat, Iltis, Santana, LT 28-50D, AUDI 80, Coupé, Quattro, 100, 200	110
Pressing down valve springs	2577-1	VW-AUDI with valve rocker arm engine 0.9–1.3 l Polo since 1982, Golf II, Jetta until 1992, Golf I Cabrio, Scirocco, Passat until 1988	110
Pressing down valve springs	2577-2	VW-AUDI bucket tappet engines from 1.3 l	110
Pressing down valve springs	2577-207/2	Polo, Golf III 1.4, 1.6 l since 1993	110
Pushing valve stem seals	2577		110
Removing valve stem seals (2-valve engines)	791-5	2-valve engines	43
Removing valve stem seals (4-valve engines)	791-8	multi-valve engines	43
Retaining the pulley e.g. on generator	4640-1 4640-2	V-ribbed belt pulley V-belt pulley	132
Screws at air flow sensor	2225-10 H up to 40 H		104
Screws at the cooling water pump (water pump, span 10 mm)	2572	Polo, Golf 0.9, 1.05, 1.1, 1.3 l	110
Screws on intake pipe	2584-1	AUDI 200 5-cyl. Turbo	111
Screws on intake pipe	2584-2	5 cyl. diesel VW-AUDI, VW van T4	111
Tightening screws as a function of the torsion angle (e.g. cylinder head screws)	6690		157
Toothed belt changing, e.g. on VW pump jet engines	2588/3		112
Toothed belt tensioning pulley	2587	1.6 l diesel VW-T 3 (until 1991), Golf, Jetta, Passat, AUDI 80	111
Toothed belt tensioning pulley	2587-1	Polo since 1995 (4 cyl.), AUDI A 4 since 1995 (4 cyl.), AUDI 100 since 1991 (5 cyl.)	111
Toothed belt tensioning pulley	2587-2	Golf III, IV, Audi A3, Skoda Octavia	111
Valve adjusting (span 3 mm)	8501 Lg-3 and 863 PC	2.0 l engines AUDI 100 S, LS, GLS, VW-LT 28, 31, 35	53
Valve reed replacement	2599	VW-AUDI from 1.3 l engines on	113
Exhaust system			
Cutting exhaust pipes up to 2.5 mm wall thickness and 80 mm ø	4682		138
Steel clamps at the exhaust system (ball flange)	2585/2, 2586 N/3	Golf 1.5 / 1.6 / 1.5 l D, Jetta 1.5 D / 1.6 l, T 4 4-cyl., Golf III / Jetta from 1984 to 1992 except 1.05 / 1.3 l / Passat model year 1988 except 4-valve engines with 4 and 6 cyl.	111
Installing and removing the lambda probe (span 22 mm)	4680-3, 4681-1, -2, -3		138
Installing and removing the lambda probe (span 22 mm)	612-19 x 22	Polo G 40 since 1992, Golf III since 1992, Passat G 60, Transporter 2.5 l since 1988 AUDI 80 since 1992, AUDI 100 Turbo since 1993, AUDI V 8 from 1989 to 1994	34
Installing and removing the rubber retainers of exhaust systems	4684-2		138
Screws on turbo charger / exhaust manifold (span 12 mm)	2590 GZ-12	Passat 1.6 diesel (since 1988)	112
Fuel supply			
Butterfly valve setting (carburettor)	4517	AUDI 80, VW-Passat 1.3-1.5 l, 1.6 l	130
Injection type engine – mixture control at the flow distributor (K-Jetronic)	4516		130
Installing and removing the injection nozzle (span 22 mm)	4555-3	Polo 1.3 l diesel	131

Application	HAZET No.	Vehicle model	Page
VOLKSWAGEN GROUP (AUDI, SEAT, SKODA)			
Fuel supply			
Installing and removing the fuel filter	986 Lg-13	VW-AUDI diesel engines with engine code AJM since 5/99 (Passat B 5, Golf IV, Bora, AUDI A3 and A4), as well as SEAT and SKODA diesel engines	67
Installing and removing the injection nozzle (span 27 mm)	4555 N	VW-AUDI, Golf Diesel	131
Screws on injection pipes (span 17 mm)	4560	4 cyl. 1.6 l, 5 cyl. 2.0 l, 6 cyl. 2.4 l Diesel engines	131
Screws on injection pump (installing and removing the toothed belt)	4561	Golf, Jetta, Caddy, Passat, Santana	131
Gearbox / Shaft			
Axle shaft nut	900 S Z-30	Golf 4, Polo, New Beetle	75
Exterior cardan shafts / bearing, transmission shaft rings of the cardan shaft	1847-6	Golf	84
Flanged shaft	1847-6	VW-T 4	84
Gearbox screws (outside TORX® screws T 40)	992-T 40	AUDI 80/90 gearbox 012	68
Gearbox screws (outside TORX® screws T 45)	992 S Lg-T 45	Passat 1.6, 1.8, 2.0 (since 04/1989)	68
Gearbox screws (outside TORX® screws T 60)	992-T 60	AUDI 80/90	68
Installing and removing cardan shafts (XZN screws M 8)	990 Lg-8	VW-AUDI	68
Installing and removing circlips at the homocinetic joint	1847-3	Passat, Golf, Polo, AUDI 80	84
Installing and removing gearbox circlips	1847-7	AUDI 80/90/100 gearbox 012	84
Installing axle collar clamps	1847-1		84
Installing special steel clamps on axle collars made of Hytrel®	1847 with 6110-1 CT		84
Progressively adjustable clamps without lug-holding-down device	1847-11		84
Retainer ring at flanged and drive shaft	1847-61	VW transporter T 2, T 4	84
Screws on cardan shafts (span 6 mm)	2584	Passat, AUDI 80	111
Separating the outer homocinetic joint of the axle drive shaft	2515/2		109
Hose coupling			
Installing and removing CLIC-type hose clamps	798-2		44
Installing and removing hose clamps coolant hoses	798-5 -10		44, 45
Installing and removing self-gripping spring band hose clamps	798-15 A		45
Installing and removing self-gripping spring band hose clamps	798-7		44
Installing and removing spring band hose clamps (on cooling and heating circuits)	798-12		45
Motor electricity			
Installing and removing glow plug sockets	4760-5	new generation of diesel engines	139
Installing and removing glow plugs	4760-8 x 12		139
Installing and removing glow plugs (span 10 mm)	2530	AUDI 80 TDi, 100 TDi	109
Installing and removing spark plug sockets	1849	Golf I, II, AUDI 80	84
Installing and removing spark plug sockets	1849-2	AUDI V6, V8 engines	84
Installing and removing spark plug sockets	1849-6	Golf, Passat, Vento, Corrado, Sharan, AUDI 100, A 4, A 6, A8 with 2.4 / 2.6 / 2.8 (V6 engines)	85
Installing and removing spark plugs (span 16 mm = 5/8")	4766-1	multi-valve engines	139
Installing and removing the V-ribbed belt at the generator (BOSCH)	2592 and 2751	Golf III, IV, Vento, Passat, SKODA, AUDI A3, A4	112
Installing and removing the V-ribbed belt pulley at the generator (BOSCH)	4641/2	Golf III, IV, Vento, Passat, SKODA, AUDI A3, A4	132
Installing and removing wedge base bulbs	4659-1		133
Releasing of cable contacts (assortment with 12 parts in wooden box)	4660-25/12		134
Spark plugs – checking the spark plug air gap	2147		96
Oil Service			
Installing and removing the oil filter cap	2169-32	Passat, AUDI, OPEL Astra, Corsa	99
Installing and removing the oil filter cap	2169-36	Lupo 1.2 TDi, model year 1999	99
Oil filters that are fitted at an angle	2169-3	Passat since 1997, AUDI A4 since 1995 as well as comparable vehicle models of SEAT and SKODA	98
Oil filters that are fitted at an angle	2169-4/2	VW-Passat Diesel since 1997, Passat Syncro since 1998, AUDI A4 Quattro since 1995, A6 since 1997, A4 Diesel since 1995, as well as comparable vehicle models of SEAT or SKODA with VAG 4-cyl.-engines	98
Steering			
Installing and removing the airbag unit (inside TORX® screws T30)	2223 Lg-T 30	Polo, Golf II, III	103
Removing the airbag unit	2525-1/2	Golf IV	109
Removing the airbag unit	2525-2/2	Passat B 5	109
Wheels			
Installing and removing tire valve cores	666-1		37
Mounting and removing tires (steel / aluminium rims)	650 K-20		37
Pulling rubber-covered valves of different sizes into the rim holes of tubeless tires	666-2		37

Application	HAZET No.	Vehicle model	Page
VOLVO			
Brakes			
Adjustment of sensors at the antilocking system	2147 MS		96
Brake bleeding (span 8, 10, 11 mm)	4968-8 -10 -11		147
Cleaning disk brake calipers	4968-1 -2		147
Extracting disk brake linings (rear)	1966-1		91
Safety bolts (∅ 4 mm) on disk brakes (rear)	748 Lg b-4		39
Chassis			
Steering – Removing ball joint pivots (size 18 - 22 mm)	779		42
Steering – Removing ball joint pivots (size 20 - 22 mm)	779-1		42
Drivetrain			
Preloading bucket tappets	2574-1	6 cyl. diesel 240, 740, 760, 940	110
Retaining the pulley e.g. on generator	4640-1 4640-2	V-ribbed belt pulley V-belt pulley	132
Tightening screws as a function of the torsion angle (e.g. cylinder head bolts)	6690		157
Valve reed replacement	2599	6 cyl. diesel 240, 740, 760, 940	113
Exhaust system			
Cutting exhaust pipes up to 2.5 mm wall thickness and 80 mm ∅	4682		138
Fuel supply			
Installing and removing the injection nozzle (span 27 mm)	4555 N	diesel	131
Motor electricity			
Installing and removing spark plugs (span 16 mm = 5/8")	4766-1	264 GL, 760 GLE	139
Spark plug cleaning	2131		96
Spark plugs – checking the spark plug air gap	2147		96
Wheels			
Installing and removing the tire valve cores	666-1		37
Mounting and removing tires (steel / aluminium rims)	650 K-20		37
Pulling rubber-covered valves of different sizes into the rim holes of tubeless tires	666-2		37

Equivalent Standard Bolt Diameters

of German, American, British, Norwegian, French and Swedish Dimensions for Wrenches

Only sizes printed in the grey column can be ordered

Metric Measurements											American Measurements						British Measurements						
Openings across flats and Nominal Size mm	Bolt Size										Openings across flats and Nominal Size		Bolt Size				Nominal Size		Openings across flats				
	DIN ISO 272					Swedish Dimensions SMS							Nuts and Screws acc. to SAE Stand.	USS		Americ. Stand.		Diameter of Thread Inch					
	Normal Hex	Large Hex	with flange		Norwegian Dimensions	French Dimensions	Metric	Whitworth	small 1414	large 1412	small 1415	large 1413		Nuts and Screws	Cap screws	Nuts and Screws	Cap screws		BSW Large Hex BS 192	BSF and BSW Small Hex BS 1083	BA		
												Inch	mm						Inch	mm			
3																			10	.117	2,97		
3,2	1,6																						
3,5																			9	.131	3,33		
4	2				1,7	2,5	2,3									0 1			8	.152	3,86		
4,5					2		2,6									2 3			7	.172	4,37		
5	2,5				2,3	3	3												6	.193	4,90		
5,5	3				2,6														5	.220	5,59		
6					3	3,5	3,5	3											4	.248	6,30		
7	4		5		3,5	4 4,5	4	3,5											1/16 = 3/32	.256	6,50		
8	5		6	5	4	5	5	4							1/8	1/8	5 6		3/32 = 1/8	.297	7,54		
9					5	5,5	5												2	.324	8,23		
10	6		8	6		6	6									3/16	10		1/8 = 3/16	.340	8,64		
11	7				6 7		7	6											1	.365	9,27		
12					7	8													0	.412	10,49		
13	8		10	8						5/16	1/4												
14					8	8		8											3/16 = 1/4	.445	11,30		
15			12	10			10												1/4 = 5/16	.525	13,33		
16	10				9					3/8	5/16								5/16 = 3/8	.600	15,24		
17					9 10	10		10															
18	12		14	12			12			7/16	3/8								3/8 = 7/16	.710	18,03		
19					11	11																	
20																							
20,8	Spark plug M 14																				7/16 = 1/2	.820	20,83
21	14	12	16	14		12	14			1/2	7/16												
22					12 14			12 14															
23						14														1/2 = 9/16	.920	23,34	
24	16	14		16			16			5/8													
25																							
26	Spark plug M 18																						
27	18	16	20		16		18	16															
28										3/4	5/8									5/8 = 11/16	1.100	27,94	
29						18																	
30	20	18		20			20													11/16 = 3/4	1.200	30,48	
32					18 20	20	22	18 20															
33										7/8	3/4									3/4 = 7/8	1.300	33,02	
34	22	20					24																

Equivalent Standard Bolt Diameters

of German, American, British, Norwegian, French and Swedish Dimensions for Wrenches

Only sizes printed in the grey column can be ordered

Openings across flats and Nominal Size mm	Metric Measurements								American Measurements						British Measurements						
	Bolt Size								Bolt Size						Nominal Size						
	DIN ISO 272				Swedish Dimensions SMS				Openings across flats and Nominal Size		USS		Americ. Stand.		Diameter of Thread Inch		Openings across flats				
	Normal Hex	Large Hex	with flange		Norwegian Dimensions	French Dimensions	Metric	Whitworth	Inch	mm	Nuts and Screws acc. to SAE Stand.	Nuts and Screws	Cap screws	Nuts and Screws	Cap screws	BSW Large Hex BS 192	BSF and BSW Small Hex BS 1083	BA	Inch	mm	
35					22					1.3/8	34,92			1.1/8					13/16 = 15/16	1.390	35,31
36	24	22			22					1.7/16	36,51	1	7/8								
37								1	7/8	1.1/2	38,10			1.1/4	1	1.1/8			7/8 = 1	1.480	37,59
38					24					1.9/16	39,69										
41	27	24			27					1.5/8	41,28	1.1/8	1	1.3/8					15/16 = 1.1/16	1.580	40,13
42					27			1.1/8	1	1.11/16	42,86				1.1/8	1.1/4			1 = 1.1/8	1.670	42,42
46	30	27			30	30				1.13/16	46,04	1.1/4	1.1/8								
47								1.1/4	1.1/8	1.7/8	47,63		1.1/4						1.1/8 = 1.1/4	1.860	47,24
50	33	30			33	33				2	50,80	1.3/8	1.1/4								
52								1.3/8	1.1/4	2.1/16	52,39				1.3/8	1.1/4			1.1/4 = 1.3/8	2.050	52,07
54					36																
55	36	33			36					2.3/16	55,56	1.1/2	1.3/8								
56								1.1/2	1.3/8	2.1/4	57,15				1.1/2				1.3/8 = 1.1/2	2.220	56,39
58					39																
60	39	36			39					2.3/8	60,32		1.1/2								
										2.7/16	61,91				1.5/8				1.1/2 = 1.5/8	2.410	61,21
63					42																
65	42	39			42			1.3/4	1.5/8	2.9/16	65,09		1.5/8						1.5/8 = 1.3/4	2.580	65,53
67					45					2.5/8	66,68				1.3/4						
70	45				45			1.7/8	1.3/4	2.3/4	69,85		1.3/4						1.3/4 = 2	2.760	70,10
71					48					2.13/16	71,44				1.7/8						
75	48				48			2	1.7/8	2.15/16	74,61		1.7/8								
77					52					3	76,20				2						
80	52				52					3.1/8	79,38		2						2 = 2.1/4	3.150	80,01
82					56																
85	56				56					3.3/8	85,72				2.1/4						
88					60					3.1/2	88,90		2.1/4								
90	60				60														2.1/4 = 2.1/2	3.550	90,17
94					64																
95	64				64					3.3/4	95,25				2.1/2						
100	68				68	68				3.7/8	98,42		2.1/2						2.1/2 = 2.3/4	3.890	98,81
105	72				72	72				4.1/8	104,78				2.3/4				2.3/4 = 3	4.180	106,17
110	76				76	76				4.1/4	107,95		2.3/4								
115	80				80					4.1/2	114,30				3				3 = 3.1/4	4.530	115,06
116					80					4.5/8	117,48		3								
120	85				84														3.1/4 = 3.1/2	4.850	123,19
130	90				89					5	127,00		3.1/4						3.1/2 = 3.3/4	5.180	131,57
135	95				94					5.3/8	136,52		3.1/2								
145	100				99					5.3/4	146,05		3.3/4						3.3/4 = 4	5.550	140,92
150	105				104																
155	110				109					6.1/8	155,57		4								

NUMERICAL INDEX



Hazet-No.	Page	Hazet-No.	Page	Hazet-No.	Page
0-9	22	858-872	53-55	3551	125
0-10	22-23			3601	126
0-11	24	880	57-59, 74-75, 77-78	3701-3703	127-129
0-12	24				
0-13	25	880-888	61-63	4373-4374	128-129
0-15	25			4501-4590	129-132
0-19	26				
0-20	27	900	63-65, 75-78		
		900-954	69-71, 76	4616-4618	132
		901-903	75-76	4640-4642	132
0-111	7-8	911-916	65	4650	132-133
0-174	13	917-958	66	4659	133
0-190	27	980-992	67-69	4660-4669	133-137
		995	76	4680-4684	137-138
0-1900	86				
0-2450	107	1000	71, 76, 78	4760-4767	139
0-2500	108	1000-1002	72-73	4770-4775	139-140
0-2700	114	1004-1007	77	4793-4811	140-141
0-2900	120	1010-1012	71-72		
0-3000	122	1014-1016	72		
0-3300	123	1017-1058	72	4813-4852	142
0-3400	123				
0-3550	125				
0-3600	126	1100	73, 77	4900	142-144
0-3700	126	1104-1107	77	4910-4911	145
0-3800	127	1114-1116	73-74	4930	145-146
0-4320	127	1117-1158	74	4950-4970	146-147
0-4350	128				
0-4370	128				
0-4390	129	1520	78	5110-5123	149
0-4410	129	1530	78		
		1555-1557	78-80		
				6002-6145	150
111	7-8			6060	156
112	8	1802-1842	80-82	6280-6296	151-153
130	8-9	1845-1847	82-84	6303-6399	153
150	27	1849	84-85	6401-6430	153-155
162-180	9-14	1850-1852	85	6450-6630	156
161	14-18	1860-1863	85	6690	157
190	27-28	1870-1875	85-86		
				6800	157
279	29	1900-1931	86-88		
425-435	29-30	1932-1933	88		
440-452	30-31	1934	89	6903-6905	157
536-537	31-32	1935-1959	89-90		
600-606	32-33	1960-1962	90		
609-645	34-37	1963-1965	90-91	7900	158
		1966-1968	91		
		1969-1973	91-92		
650-720	37-38	1975-1981	92-93	8501-8507	53
730-751	38-39			8505-8508	74
752-758	39-40				
759-760	40-41	2025-2026	93		
769-772	41	2100-2117	93-95	8801-8808	59-60, 75
775-789	41-43	2119-2166	95-98	8811-8816	60
790-795	43-44	2168-2172	98-100	8820-8858	61
796-799	44-45	2173-2195	100-101		
		2204-2351	102-106		
		2460	107	9005-9008	76
801	46-47			9011-9040	159-161
803	47-48				
805-808	48-49	2500-2572	108-110		
815	49	2574-2577	110-111		
818-819	49	2579-2599	111-113		
820-825	49-50				
828	50				
838	50	2714-2796	115-118		
839	50	2800-2870	118-119		
840-849	50-51	2900-2991	121		
850	52-53, 57, 74	3012-3092	122		
850-855	55-57	3428-3499	124		

Description	Page
A Abrasive Rings	146
Acid Tester	133
Adapters	53, 61, 66, 72, 74-77, 104, 106, 112, 115, 124, 141, 155
Adjustable Legs	9
Adjustable Wrenches	29
Adjustment Wrench	153
Air Blow Guns/Pen	160
Air Drill	160
Air Ratchets	160
Air Tools and Accessories	74-80, 115, 117, 119, 125, 159-160
Aircraft Tools	26, 51-53, 81, 102-103
Aligning Tool Set	92
Allen Keys	93-95
Angle Scrapers	49
Anti-Freezing Acid Tester	141
Anvils (Dollies)	87-88
Assembly Tools	116, 146
Assistant and Accessories	9-15
AUDI Tools (see VW-AUDI)	108-113
Automatic Wire Strippers	85
B Balance Weight Pliers	37
Ball Joint Pullers	42
Ball Tip Extensions	55, 61, 66
Ball Tip Screwdrivers	59, 67, 94-95, 102, 109
Base Blocks	101
Battery Service Tools	96, 132-133, 141
Bending Tools	88, 101
Bit Holder for Screwdriver Bits	104-105, 113, 118, 130, 155
Bits and Accessories	17-18, 102-106, 113, 118, 130, 154
BMW Tools	120-121
Body and Fender Tools	24, 39-40, 86-91
Box-End Wrenches	32-37, 51, 112, 115-116, 119, 130-131, 138-139, 147, 156
Ratcheting	33-35, 139
Striking Face Pattern	36-37
Brake Adjusting Tools	34, 44, 111, 118, 121, 146-147
Brake Spring Pliers	44, 118
Brushes and Files	89, 95-96, 147
C Cabinet Trolley for Workshop	12-13
Cable Drum	15
Cable Extractor Tools	133-137
Cable Stripping Knives	97
Caliper Files	147
Caliper Gauges	97, 146
Camshaft Locking Tool	112
Car Light Tester	96
Carburettor Tools	130
Cardan (Universal) Joints	55, 61, 66, 72, 74-77
Cartridge Wrenches	101
Caulking Irons	87-88
Center Punches	39
Chisels	38-39, 90
Chisel Hammer	160
Choke Angle Meter	130
CHRYSLER Tools	124-125
Circlip Pliers	16, 82-84, 115
Clip Screwdriver	48
Clutch Centering Tools	100
Combination Lever	91
Combination Pliers	85
Combination Wrenches	32-33
Combinational Sockets	132
Compressed Air Adapter	115, 124
Connector Pliers	81
Coolant Thermometer	141
Counter Stays	43
Countersinking Punch	88
Crown Wrenches	131
Cutters	85-86, 90, 97
Cylinder Head Leakage Tester	141

Description	Page
C Cylinder Head Tools	110-111, 116, 119, 121-122, 124-125, 140-141
D Deburring Tool	101
Depressors	110, 124
Diagonal Cutters	80-81, 85-86
Digital Caliper	97
Dollies	87-88
Door-Spring Pliers	45
Double Box-End Wrenches	34-36, 131, 139
Double Open End Wrenches	30-31
Double-Pin Wrenches	111
Drawer Inserts	15-19
Drawer Partition System	14-15
Drift Pins	39
Drift Punches	38
Drill Bits	91, 95
Drive Nuts	112, 118
Drive Shaft Puller	91
Driving Tool for Tensioning Device	112
Dynamometric Screwdrivers	150, 153
E Electronic Pliers	85-86
Electronic Screwdrivers	48-49
Electronic Torque Tester	158
End Cutting Pliers	81
Endoscope	141
Engine Leakage Tester	140
Exhaust System Tools	111, 138
Extensions	32, 41, 55, 61, 66, 72, 74-77, 117, 140
Extractors	41-43, 91-92, 109, 133, 145
F Feeler Gauges	96
FIAT Tools	126
Files and Brushes	89, 95-96, 147
Fine-Tooth Reversible Ratchet	54, 60, 65, 154
Flange Tools	88
Flare Nut Insert Tools	51, 116, 130, 138, 147, 156
Flare Nut Wrenches	34, 112, 131
Flex Head Socket Wrenches	109
Flexible Combination Wrenches	33
Flexible Extensions	55, 61, 66
Flexible Handles	54, 60, 65
Flexible Head Wrenches	37, 129
Flexible Hex Head Wrenches	121
Flexible Hex Nut-Drivers	29
Flexible Hose Clamps	131-132
Flexible Inspection Light	92
Flexible Screwdrivers	29, 105, 130
Forcing Screws	109
FORD Tools	123-124
Fork Wrenches	30-33, 113, 115, 117, 119, 156
Four-Way Rim Wrenches	38
Fuel Supply Tools	109-110, 116, 129-132
G Gear Pullers	42
General Purpose Spoons	88
General Workshop Equipment	7-28
Glow Plug Socket Pliers	139
Glow Plug Wrenches	109, 139
Grease Guns	97
Grip Pliers	48
Grip Welding Clamps	40
Gripping Jaws	101
Guide Pin Drivers	110
H Hack Saws	92-93
Hammers	89-90, 96
Hand Anvils (Dollies)	87-88
Hand Guard for Chisels	38
Handle Bars	41, 72-74
Handle Bar with Sliding Head	72-73
HARLEY DAVIDSON Tools	107
Heavy Duty Box-End Wrenches	36
Heavy Duty Combination Pliers	85

Description	Page
H Hex Head Wrenches	93-95, 112
Hex Nut-Drivers	29
Hexagon Sockets	31, 52-53, 57-59, 63-65, 71, 74-77, 110-113, 116, 119, 130, 137-138, 140, 142, 145
HONDA Tools	129
Hose Clamp Pliers	44-45
Hub Puller	42
Hydraulic Torque Tester	157
I Idler Pulley Wrench	112
Ignition Adjustment Wrench	112
Impact Extractors	91-92
Impact Screwdrivers	106
Impact Sockets and Accessories	74-80, 115, 117, 119, 125
Impact Wrenches	159
Insert Tools for Torque Tools	113, 115, 138, 147, 153-156
Inspection Mirror	92
Internal Extractors	43
K Knives	97
»Komposit« Reversible Ratchets	32, 54, 60, 65
L L-Shaped Wrenches	49, 94-95, 113
Leak-Off Pliers	131
Lever for Removing Door Panels	45
Light Tester	96
Lights/Lamps	92
Locking Adapters	55, 61, 66
Locking Extensions	55, 61, 66
Lockring Pliers	16, 82-84, 115
Long Nose Pliers	81-82
M Machinist's Vice	100
Magnetic Pick-Up Tools	92
Magnetic Socket Inserts	66
MAN Tools	119
Mandrels	109, 146
Marking Tools	96
MAZDA Tools	128
Mechanical Angle Dials	157
MERCEDES-BENZ Tools	114-119
Micro-Grip Pliers	39
Micrometers	97
MITSUBISHI Tools	129
Motorcycle Tools	107
Mounting Hooks	138
Mounting Lever	115
Multipurpose Pliers	82
N NISSAN Tools	128-129
Nozzle Adjusting Tools	142
Nut Splitters	51
O O-Rings, Steel Pins, Safety Springs	77-78
Offset Screwdrivers	49, 94-95, 113
Oil Filter Wrenches	98-100
Oil Service Tools	110, 117, 119, 126-127, 129, 131-132
Oilers	97
OPEL Tools	122
Open Box-End Wrenches	34-35, 51, 112, 116, 119, 130-131, 138, 156
Open End Wrenches	30-33, 113, 115, 117, 119, 156
Open End Wrenches Striking Pattern	31
Optical Tester	141
P PEUGEOT Tools	126-127
Phillips-Recess Screwdriver Sockets	46-49
Phillips-Recess Screwdrivers	46-49
Pick-Up Tool - magnetic	92
Pick-Up Tool with claws	92
Pin Handles	30
Pipe Cutters	101, 138
Piston Ring Tools	43-44

Description	Page
P Pitman Arm Pullers	42
Pliers	16, 37, 39-41, 43-45, 80-86, 88, 90-91, 100, 113, 115, 118, 121, 124, 129, 131-133, 139-140, 147
Axle Collar Clamps	84
Body and Fender Grip	39-40
Brake Spring	44, 118, 147
Circlip	16, 82-84, 115
Combination	85
Diagonal Cutting	81, 86
Dismantling Door Panels	45
Door-Spring	45
Electronic	85-86
End Cutting	81, 86
Grip	39-40
Hose Clamp	44-45, 84
Lockring	16, 82-84, 115
Long Nose	81-82
Micro Grip	39
Moulding	115
Multipurpose	82
Relay	139-140
Round Nose	81, 86
Seaming	88
Side Cutting	80-81, 85-86
Snipe Nose	81-82, 86
Spark Plug Socket	84-85
Swedish Pattern	100
Universal	40-41
Waterpump	40-41
Wheel Nut Caps	37
Pneumatic Tools	159-160
PORSCHE Tools	123
POZIDRIV® Screwdriver Sockets	53
POZIDRIV® Screwdrivers	46-48
Precision Knife-Edge Straightedge	96
Precision Micrometers	97
Pry and Bumping Spoon	88
Pry Bars	98
Pulley Extractors	43
Pullers	41, 91-92
Punches	38-39
R Relay Pliers	139-140
RENAULT Tools	127
Retainers	100-111, 113, 132
Reversible Ratchet Heads	72-73, 154
Reversible Ratchets	32-35, 54, 60, 65, 72-74, 105-106, 109, 149-150, 153-154
Reversible Ratchets for Bits	105-106, 154
Rim Wrenches	41
Ring Wrenches	32-37, 51, 112, 115-116, 119, 130-131, 138-139, 147, 156
Riveting Tools	90
Round Nose Pliers	81-82, 86
Rubber Hammer	96
Rubber Rings, Steel Pins, Safety Springs	77-78
S "Safety Lock" Security System	66
Safety Spring Vice and Accessories	142-144
Safety Springs	77-78
Sales Display Chest	93
Scrapers	49-50
Screw Extractors	50
Screwdriver Bits and Accessories	17-18, 102-106, 113, 118, 130, 154
Screwdriver Sockets	16-17, 19, 53, 59-60, 67-69, 71-72, 76, 78-80, 108, 111, 116, 122, 132
Screwdriver with 5-star profile	50
Screwdrivers	18-19, 46-50, 104-106, 110, 112-113, 130
according to Swiss Standard	46
for Electricians	48
for Phillips-Recess screws	18-19, 46-49
for POZIDRIV® screws	18, 46-48, 101
for slotted screws	18-19, 46-50, 130
for TORX® screws	18, 46-50, 79, 95, 115

Description	Page
S Screwdrivers	
ULTRA	46
with ball tips	59, 94-95, 102, 109
Seal Puller	117
Seal Pushers	110, 121
Seaming Pliers	88
Separators	41
Sheet Metal Tools	24, 39-40, 86-91
Shock Absorber Tools	112-113, 117-118, 121, 145
Side Cutting Pliers	80-81, 85-86
Single Box-End Wrenches	51, 112, 131, 156
Single Open-End Wrenches	29, 31, 113, 115, 117, 131, 156
Snipe Nose Pliers	81-82, 86
Socket Sets	15-19, 30-32, 55-59, 61-63, 67-74, 76, 78-80, 118
Sockets	31, 52-53, 57-59, 63-65, 71-77, 109-113, 115-117, 119, 121-122, 124-126, 128, 130-131, 137-140, 142
6-point	31, 52-53, 57-59, 63-65, 71, 74-77, 110-113, 116, 119, 130, 137-138, 140, 142, 145
12-point	52-53, 57-58, 64, 71, 73, 75, 112-113, 115-117, 119, 125, 130-131
impact operation	74-78, 115, 117, 119, 125
manual operation	31, 52-53, 57-59, 63-65, 71, 73, 110-113, 115-116, 119, 121-122, 128, 130-131, 137-140, 142
for lambda probes	137-138
Spare Parts	161-170
Spark Plug Brush	96
Spark Plug Socket Pliers	84
Spark Plug Socket Remover	85
Spark Plug Sockets and Wrenches	58-59, 64-65, 109, 117, 128, 139
Special Tool for MERCEDES-Star	116
Specialty Tools	91-93, 95-101, 107-147
AUDI	108-113
Battery Service	96, 133, 141
BMW	120-121
Body and Fender	24, 39-40, 86-91
Brakes	44, 111, 118, 121, 146-147
Car Electricity/Electronics	133-137, 139-140
Carburettor	130
CHRYSLER	124-125
Clutch	100
Cooling System	140-141
Exhaust System	111, 138
FIAT	126
FORD	123-124
Fuel Supply	109, 116, 129-132
HARLEY DAVIDSON	107
HONDA	129
MAZDA	128
MERCEDES-BENZ	114-119
MITSUBISHI	129
Motorcycles	107
NISSAN	128-129
Oil Service	98-100, 110, 117, 119, 121, 126-127, 129, 131-132
OPEL	122
PEUGEOT	126-127
PORSCHE	123
RENAULT	127
VOLKSWAGEN-AUDI	108-113
Speeders	54, 60, 65
Spring Vices and Accessories	111, 142-144
Spring-Return Rules	97
Square Holder	154
Square Through-Plug	117
Steel Wire Brush	147
Stethoscope	96
Stud Extractors	51
Swedish Pattern Wrenches	100
SYSTEM-Release-Tools	133-137

Description	Page
T T-Handles	54, 60, 65, 72-73
Tap and Die Set	52
Tape Measures	97
Taper Keys	111
Tension Chain	117
Tensioning Jaws (Safety Spring Vice)	142-144
Test Cable "Power Probe"	96
Tester for Cooling Systems	140-141
Testing Set for Car Electricity and Electronics	96
Thread Restorers	95
Three-Square Scrapers	49
Thrust Blocks	101
Tire Irons	37
Tool Assortments	7-8, 12-13, 15-28, 86, 107-108, 114, 120, 122-129
Tool Boxes	27-28
Tool Cabinets	7
Tool Cases	27-28, 78
Tool Chests	10
Tool Hangers and Socket Rails	7-8, 57, 63, 71, 93
Tool Holders	93
Tool Table	15
Tool Trolleys "Assistant" and Accessories	9-15
TORQ-SET Screw Driving Tools	103
Torque Multipliers	157
Torque Testers	157
Torque Tools and Accessories	148-158
Torque Wrenches	148-151, 153
Torsion Angle Testing Device	157
TORX® Screw Driving Tools	16-19, 34-36, 47-50, 53, 58-59, 64, 68-69, 72, 74-76, 78-80, 94-95, 103, 111, 113, 115-116, 119, 121-122, 127, 156
TORX® Screwdrivers	18, 46-50, 113, 115
TOYOTA Tools	127
Track Rod Wrench	146
Trimming Knife	97
trinamic® Screwdrivers	47
TRI-WING Screw Driving Tools	102
Tube Cutters	100, 138
Tube Flaring Tools	101
Tubular Box Wrenches	29-30
Tubular Handles	36
U ULTRA Screwdrivers	46-47
Universal Adapters (Cooling System)	141
Universal Joints	55, 61, 66, 72, 74-77
Universal Pliers	40-41
Universal Shears	97
V Valve Tools	37, 43-44, 110-111, 113, 115, 117-118, 124
VDE Tools	27, 48, 50, 80-82, 85-86, 97
Vernier Caliper	97
VOLKSWAGEN-AUDI Tools	108-113
Voltmeters	50
W Waterpump Pliers	40-41
Wedges	91
Welding Spot Cutters	91
Wheel Bearing Extractor	145-146
Window Extracting Knife	142
Window Pane Holder	15
Wiper Adjusting Tool	142
Wire Brushes	95-96
Wire Strippers	85
Wire Twisters	81
Work Bench and Accessories	8
Wrenches	29-38
X XZN Screw Driving Tools	19, 59-60, 68, 94, 102, 110, 113, 116, 118, 122, 132



Select the right tool.

Use the tool according to the operating instructions.

Wear eye protection.

Keep tools clean.

Insulated tools (according to VDE-standards) must be used when working on live components.



Read instructions before use.



Measuring units serve to select the right-sized tools.



Wear eye protection.



An optimal frictional connection guarantees a long serviceable life of tools and screws.



Use ear protection.



Do not modify any tool.



Only use suitable specialty tools to extend the lever arm.



Never use standard sockets and insert tools with an impact wrench.



Do not hit hand tools with a hammer.



Never open more than one drawer at a time (danger of tipping over).



Avoid splintering due to wrong striking.



Never use drawers as a ladder.



Never use a screwdriver as a chisel or lever.



Do not pull tool trolleys behind you.



Select screwdriver with an appropriate blade. Always be sure that the screwdriver blade is vertical to the screw.



Dispose of worn-out tools properly.



Suggestions for Improvement

HAZET is continuously working on further improvements of their tools.

Help us to improve our service!

Did you miss any tool?

Tell us your ideas. Attractive prizes from the HAZET range of products will be awarded for the best suggestions.

e-mail export@hazet.de

FAX +49 (0) 21 91 / 792-400 • HAZET-WERK • Export Department

Sender:

Company: _____

Name: _____

Address: _____

Phone: _____

Fax: _____

E-Mail: _____ @ _____

Your fast link to HAZET



Please describe your suggestion for improvement as detailed as possible:

HAZET[®]

Ingenious Tools

